

URYU

POWER TOOLS GENERAL CATALOG





USP



USG-181C

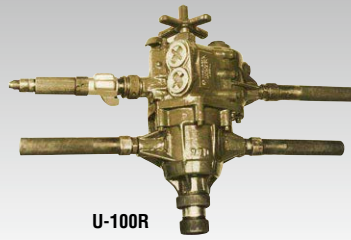

U-100R



U-900



S-1-3

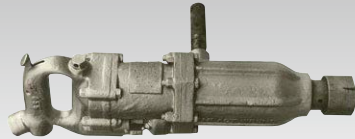

UW-38



UH-10

100 years for **URYU** is history of “Challenges” pursuing innovative tools.

We hope to introduce products which are satisfied in every operation scenes in customers stand.
This is in our initial origin and our future subject.
We will keep progress with strong spirit of investigation and
dedicate to society with best products meeting social confidence from now on.



HO-1



B-100



UW-125S



URD-23R



F-1N

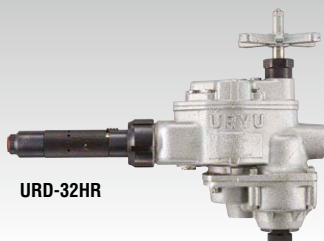

URD-32HR



UW-60E



P-20



UDBP-A50 (P)



UDBP-TA40



UDP-A60MC



UDP-TA50D (B)

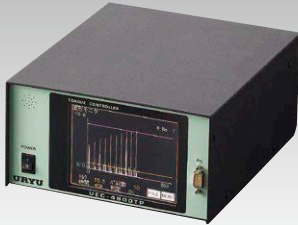

UEC-4800TP (SD)



UEC-4800 (SD)



UECP-4800



UTM-1500



→ Towards the next innovation.



UA700AMC



UA50MC



UA70SMC

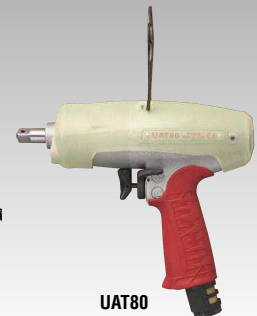

UAT80



UA50SL



UAN-F130-025



UFT-10



UDT-25

PIONEER of PNEUMATIC TOOLS in JAPAN established in 1915

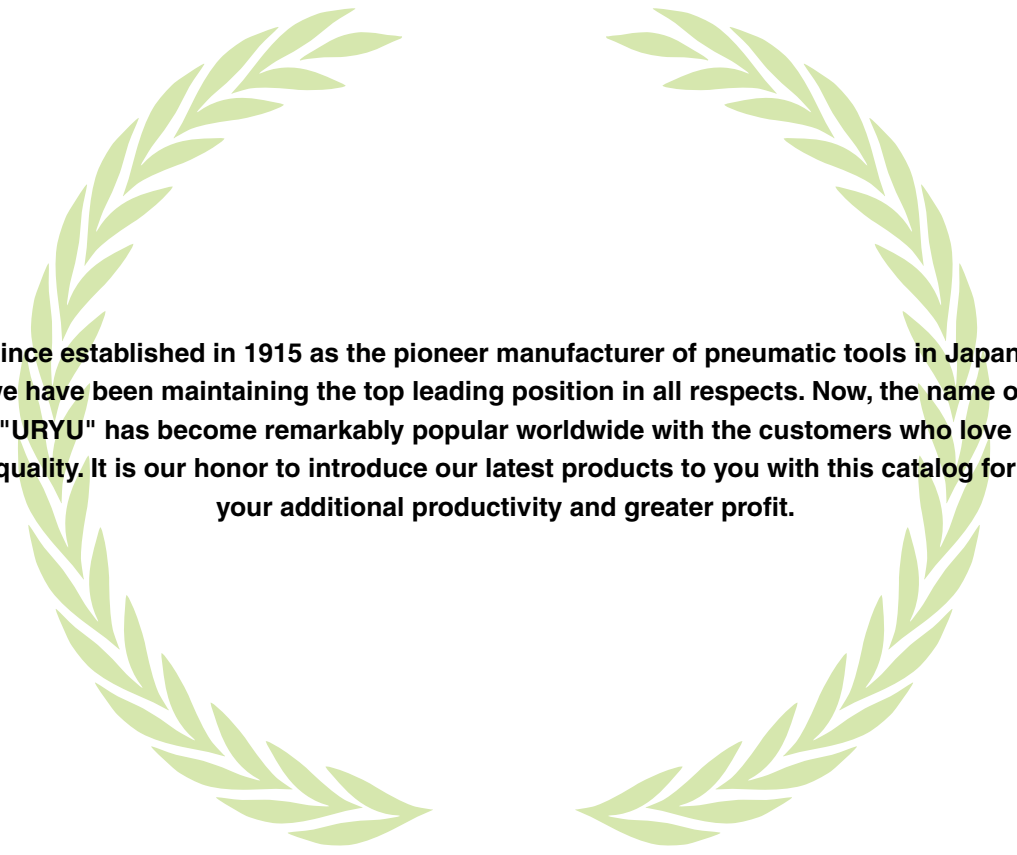

Since established in 1915 as the pioneer manufacturer of pneumatic tools in Japan, we have been maintaining the top leading position in all respects. Now, the name of "URYU" has become remarkably popular worldwide with the customers who love quality. It is our honor to introduce our latest products to you with this catalog for your additional productivity and greater profit.

URYU has acquired ISO14001 and ISO9001 certifications.

CONTENTS

BOLT & NUT SETTERS	5
URYU AUTO-RELIEF FUNCTION(PAT.)	6
SELECTION CHART	8
BATTERY OIL-PULSE TOOLS	12
ELECTRIC OIL-PULSE TOOLS	15
SUPER "INTELEC" SYSTEM SERIES	17
ELECTRIC ANGLE NUTRUNNERS	28
OIL-PULSE TOOLS	
UAT SERIES	29
UL SERIES	32
CORNER TYPE	33
U / UX / UXR SERIES	34
RATCHET WRENCHES	35
OPEN-END / GEARED WRENCHES	36
ANGLE NUTRUNNERS	37
IMPACT WRENCHES	38
SELECTION CHART	39
FASTENING COUNTER WITH POKA-YOKE	44
NUTRUNNERS	46
SCREWDRIVERS	47
SELECTION CHART	49
TORQUE CONTROL	50
CUSHION CLUTCH / IMPACT / OTHERS	52
ABRASIVE TOOLS	56
GRINDERS	57
SANDERS / POLISHERS	64
DRILLS & TAPPERS	67
DRILLS	68
TAPPERS	70
PERCUSSION TOOLS	71
RIVETING HAMMERS	72
IMPACT CUTTERS / FLUX CHIPPERS	74
CHIPPING HAMMERS	75
TESTERS & ACCESSORIES	77
TESTERS	78
ACCESSORIES	82
SAFETY MANUAL	84
NOISE & VIBRATION	87
URYU NETWORK	101

NOTES

A series of horizontal dotted lines for writing notes, spanning the width of the page.

BOLT & NUT SETTERS

BATTERY OIL-PULSE TOOLS
ELECTRIC OIL-PULSE TOOLS
SUPER "INTELEC" SYSTEM CONTROLLER
SUPER "INTELEC" SYSTEM ELECTRIC OIL-PULSE TOOLS
SUPER "INTELEC" SYSTEM AMC · MC TOOLS
ELECTRIC ANGLE NUTRUNNERS
UAT · ULT · UXR-T · UL SERIES OIL-PULSE TOOLS

U · UX · UXR SERIES OIL-PULSE TOOLS
RATCHET WRENCHES
OPEN-END WRENCHES · GEARED WRENCHES
ANGLE NUTRUNNERS
IMPACT WRENCHES
FASTENING COUNTER WITH POKA-YOKE
NUTRUNNERS

URYU independent new technology "Auto Relief Function"(PAT.)

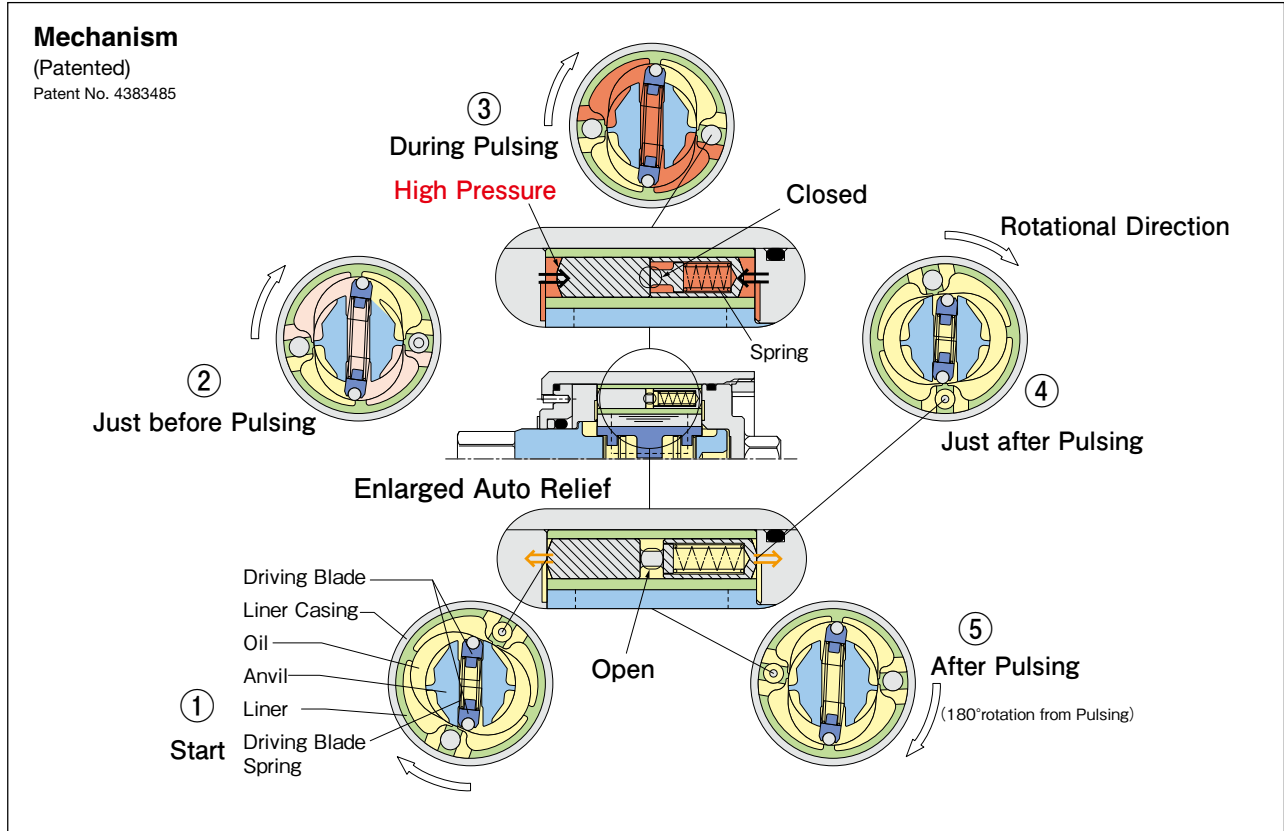

Relief Valve changes the area of bypass which plays its roles in transferring the oil pressure generated in pulse unit from high pressured area to low pressured area and adjusts the torque and number of blows depending on the target torque.

However, the area of bypass in the existing relief valve system is decided at a proper adjustment position of final target torque, thus it was not possible to change the area of bypass while fastening. Newly developed "Auto Relief Function" changes the area of bypass depending on the process of fastening, which the existing relief valve does not. This new function offers you more ideal fastening than the conventional relief valve.

*As auto-relief is fully opened when the bolt seats, torque spike is inhibited.

Also, make the final target torque adjustment with Relief Valve as heretofore

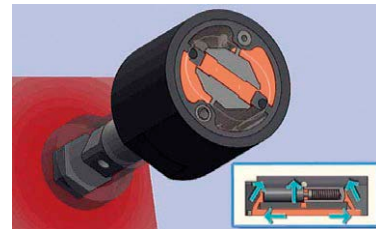

Fully opened relief valve when pulsing.

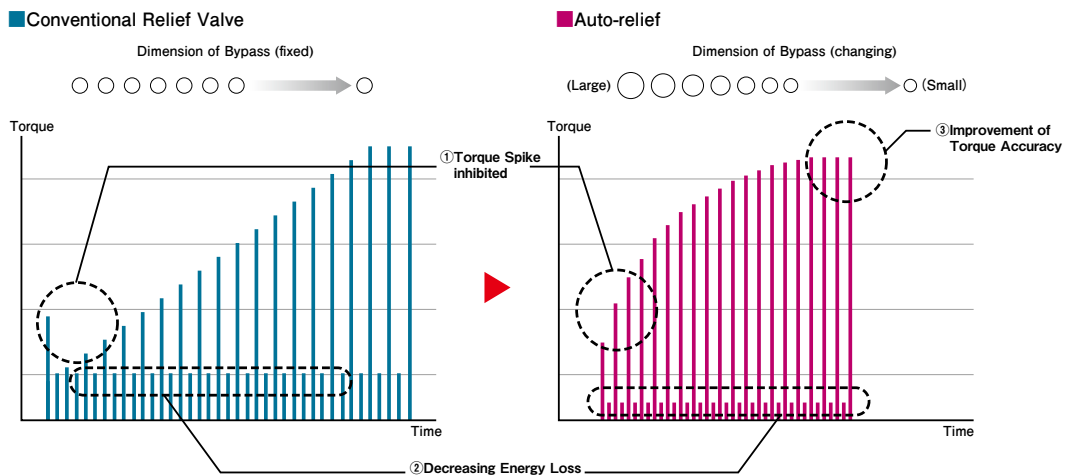

① Torque Spike Inhibited

As auto-relief is fully opened when the bolt seats, torque spike is inhibited.

② Decreasing Energy Loss

Heat generation of pulse unit is inhibited. Oil pressure to sealing part of anvil is reduced.

③ Improvement of Torque Accuracy

By reaching the stability range faster, the range of small variation can be used in fastening time of real operation. Therefore, the torque accuracy will be stable.

Magnetostrictive Transducer

URYU's brushless Magnetostrictive Torque Transducer consists of Anvil and a pair of sensor coils. Without contacting to the Anvil, the sensor coil detects load given to the Anvil (non-contact). The grooves in the anvil are provided at 45 degree angle in one region. When torque is applied to the Anvil, tensile stress appears on the region and magnet permeability increase. These permeability changes are detected, respectively transformed to the voltage change (proportional to applied torque) and converted to torque signal to control the tool.

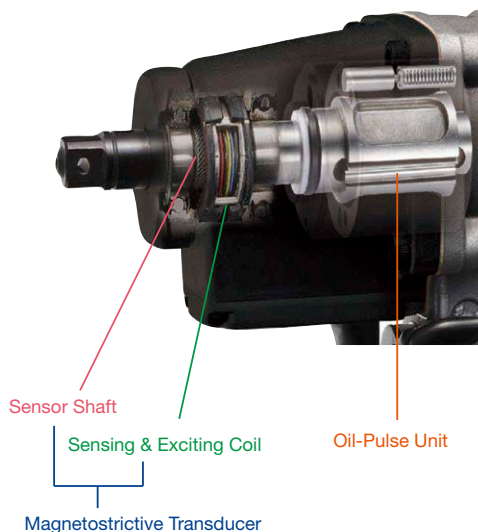

Angle Sensor

Angle measurement is materialized by the resolver incorporated. The high reliability copes well with various factors such as vibrations and ambient temperature changes.

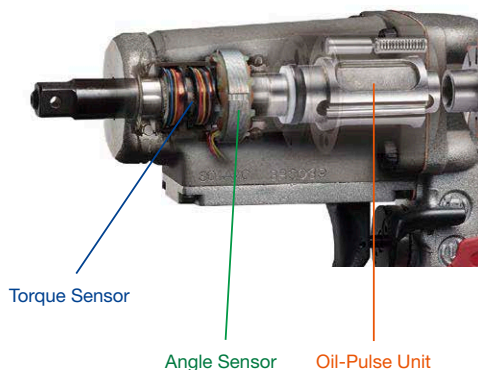

Air Motor

For lower torque ranges of types (UAT30D ~ UAT50 Series, UA40MC ~ UA60MC, UA-SMC Series and UA400AMC ~ UA600AMC), we newly developed the Triple-Chamber pneumatic type motor for medium speed but high output power. The Triple-Chamber motor makes it possible to maintain the low rotation speed, keeping the same motor output power from the conventional Dual-Chamber pneumatic motor in order to inhibit torque spikes caused by inertia from rotation speed of motor.

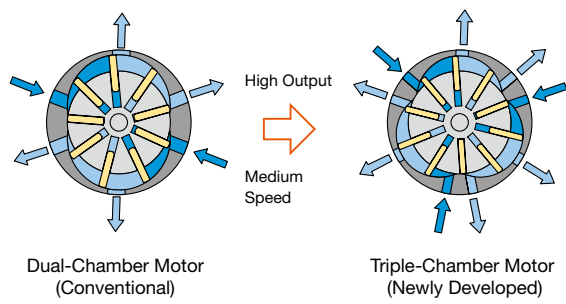

SELECTION CHART

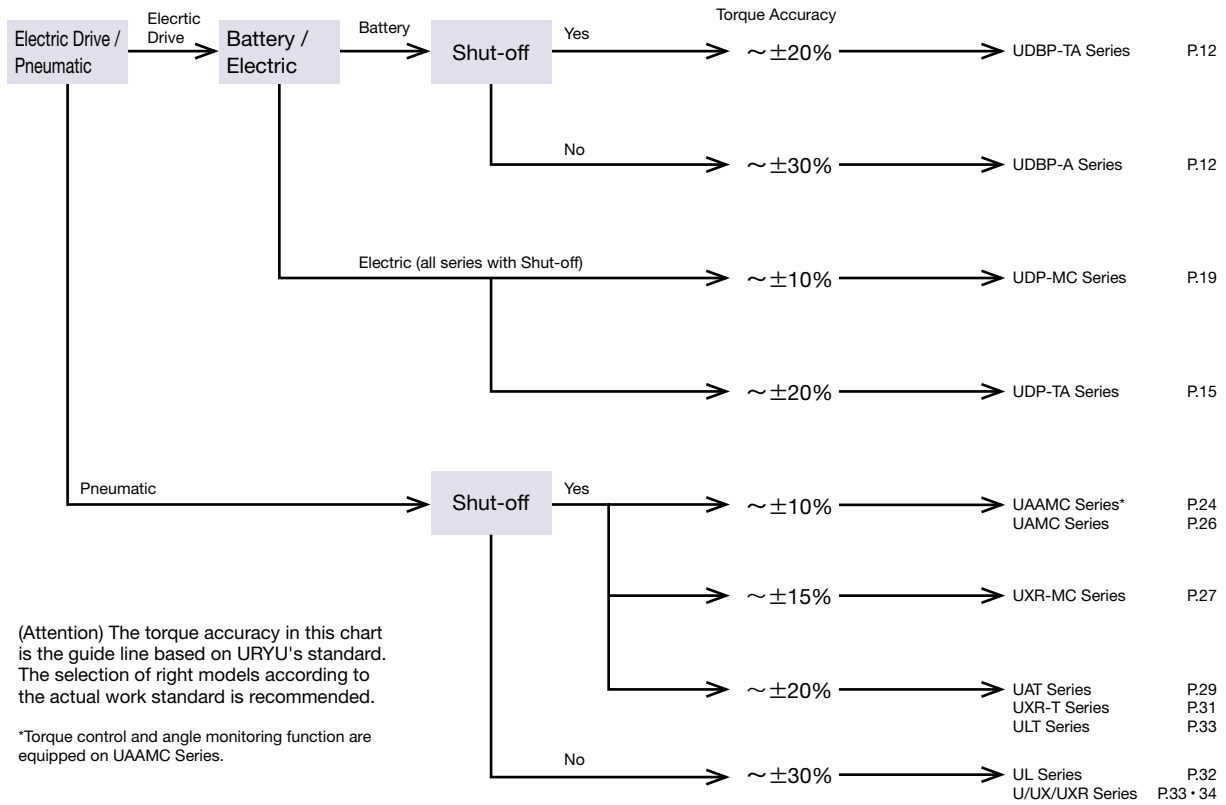

(Attention) The torque accuracy in this chart is the guide line based on URYU's standard. The selection of right models according to the actual work standard is recommended.

*Torque control and angle monitoring function are equipped on UAAMC Series.

TOOL SELECTION:

Fig. 1 Joint

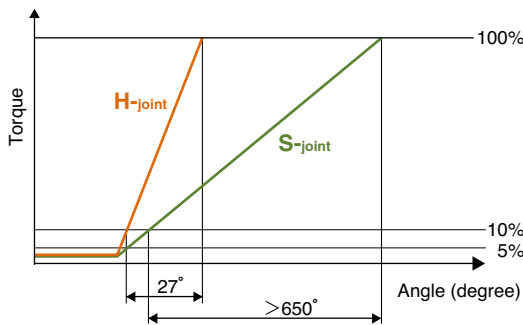

When selecting the tool for fastening operation, it is necessary to consider bolt size, fastening torque, working conditions and so on.

Generally, working conditions can be defined as hard joint (H-joint) and soft joint (S-joint) from the aspect of relation between fastening torque and angle. (Please refer to ISO-5393.) It is also necessary to consider characteristics of work pieces.

Fig. 2 Fastening with Oil-Pulse Tool (H-S Joint)

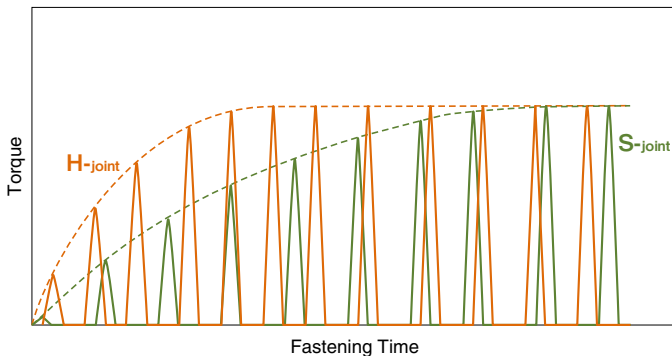

As shown above Fig. 2, torque output curve of the hard joint and soft joint is different when the same torque setting against same tool is applied.

(Difference of torque raise up speed and time to reach the target torque.)

Fig. 3 Tool selection by work feature

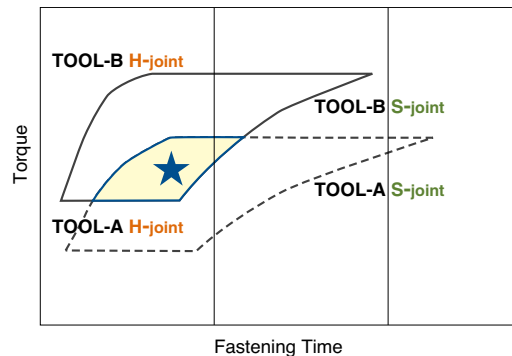

When selecting the tool against the target torque of ★ as shown Fig. 3, pay attention to the operating conditions (tool weight, fastening time), required torque accuracy, torque adjusting position of tools and select the most suitable model.

TORQUE CHART FOR OIL-PULSE WRENCHES

Pistol Type



BATTERY TOOL

● UDBP SERIES (P.12~14)

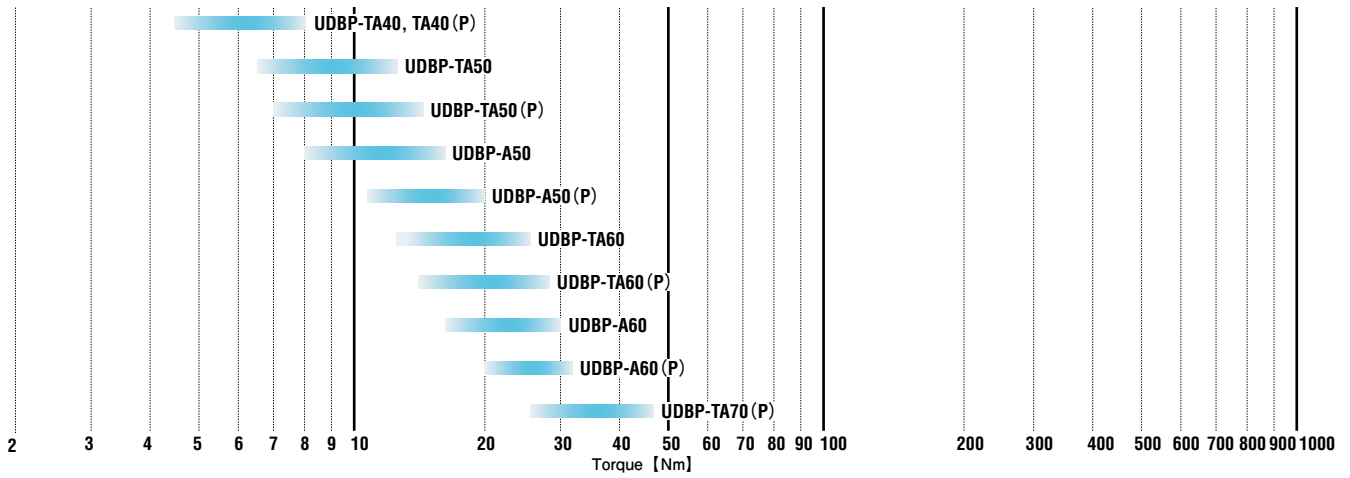

ELECTRIC TOOL

● UDP-TA SERIES (P.15)

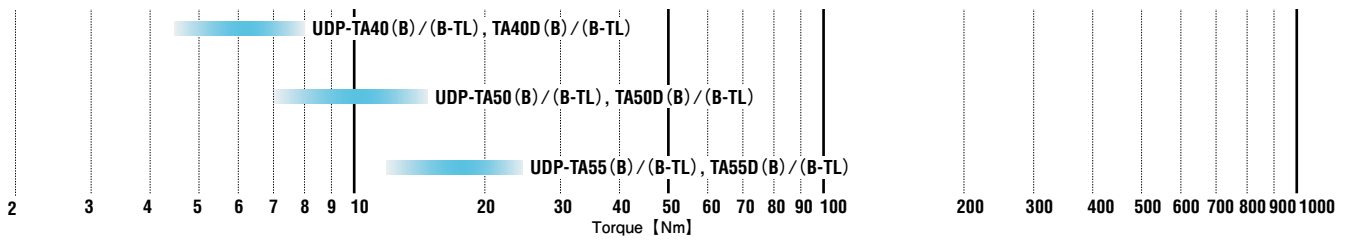

ELECTRIC TOOL (TRANSDUCERIZED TYPE)

● UDP-MC SERIES (P.19)

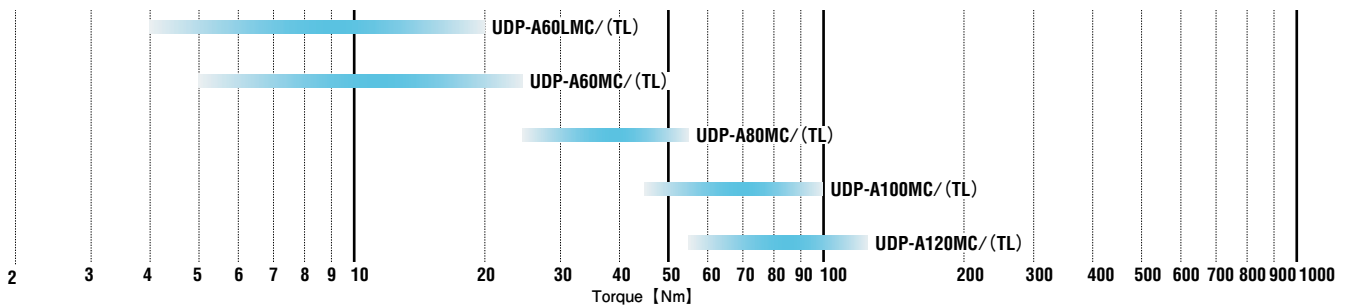

TORQUE CHART FOR OIL-PULSE WRENCHES

AIR TOOL (TRANSDUCERIZED TYPE)

●UAAMC SERIES (P.24, 25)

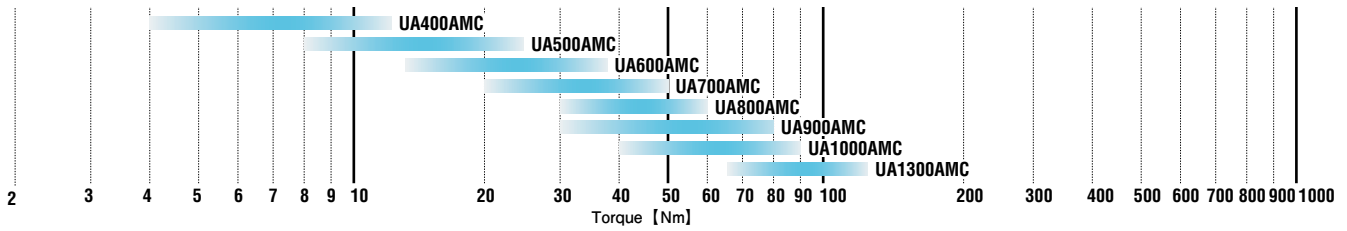

●UAMC SERIES (P.26, 27)

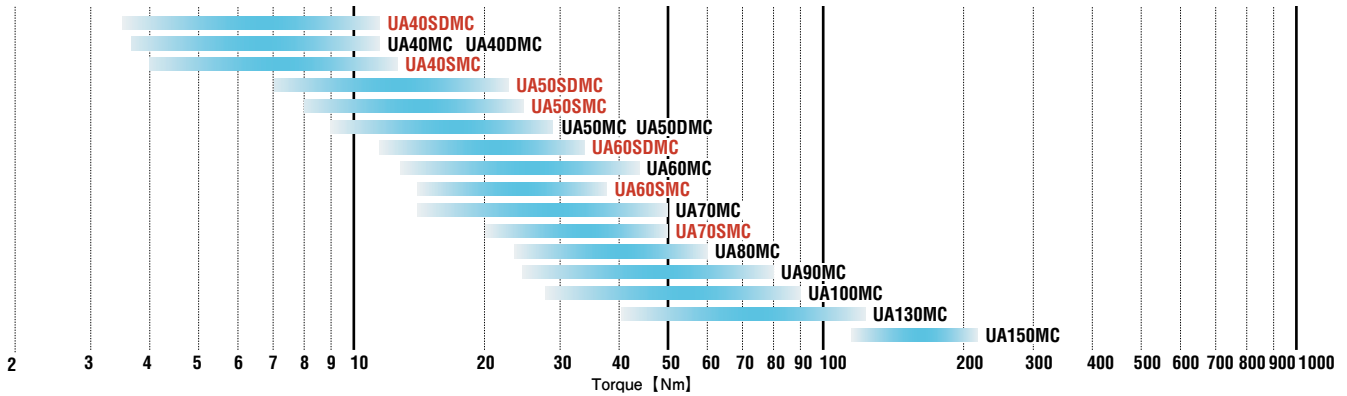

●UXR-MC SERIES (P.27)

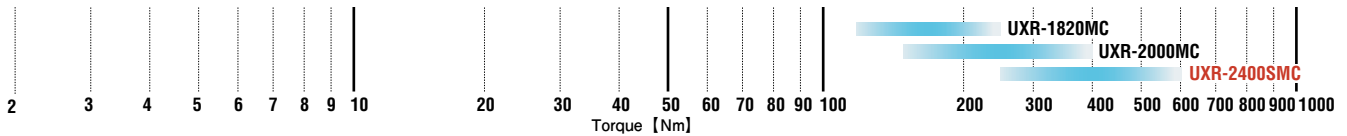

AIR TOOL (SHUT-OFF TYPE)

●UAT SERIES (P.29~31)

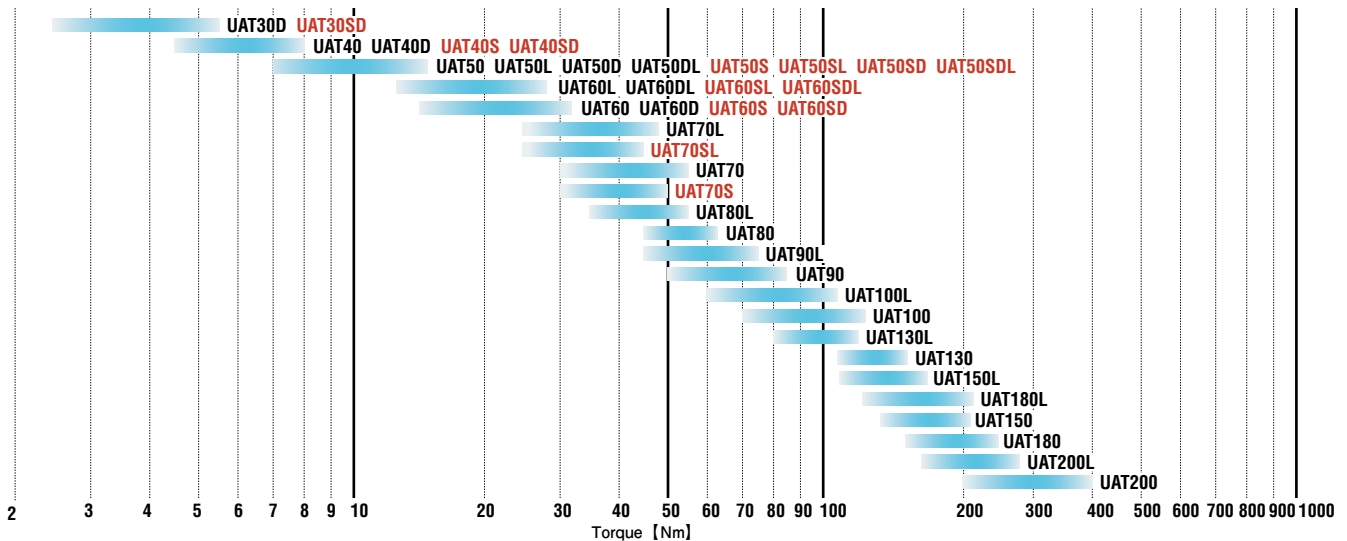

●UXR-T SERIES (P.31)

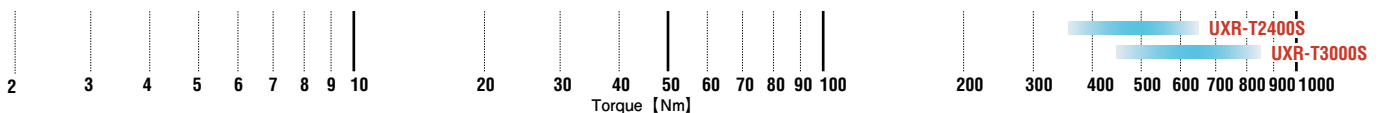

Pistol Type



Straight Type



Right Angle Type



Angle Type



AIR TOOL (SHUT-OFF TYPE)

● ULT SERIES (P.33)

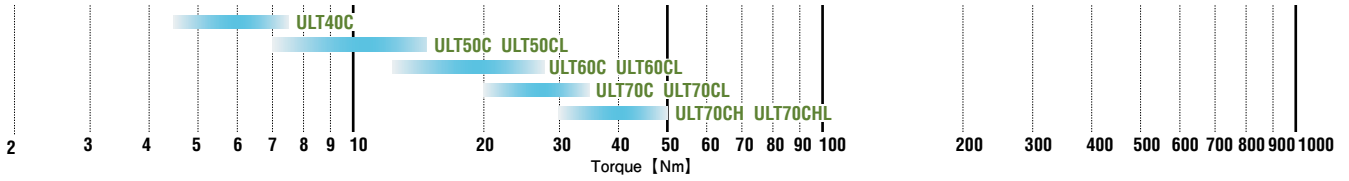

AIR TOOL (NON SHUT-OFF TYPE)

● UL SERIES (P.32)

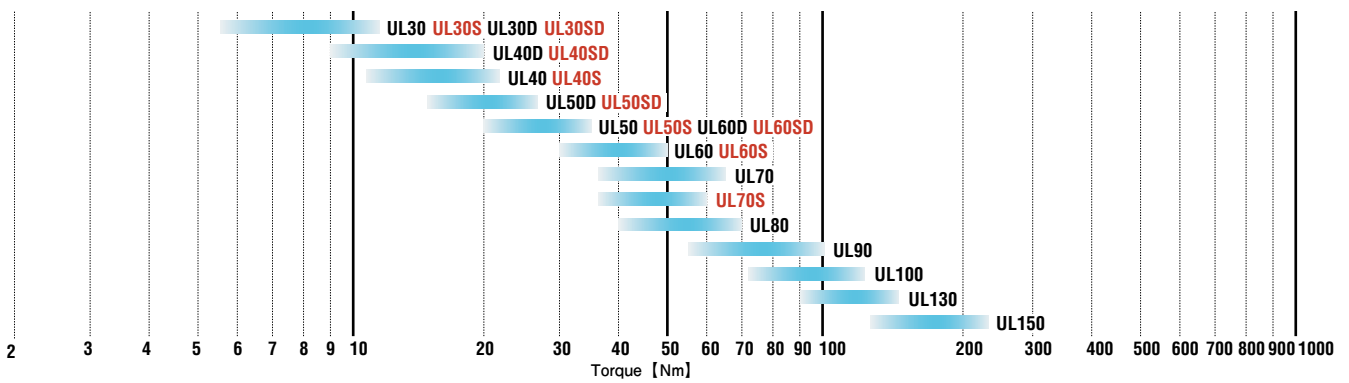

● U / UX / UXR SERIES (P.33, 34)

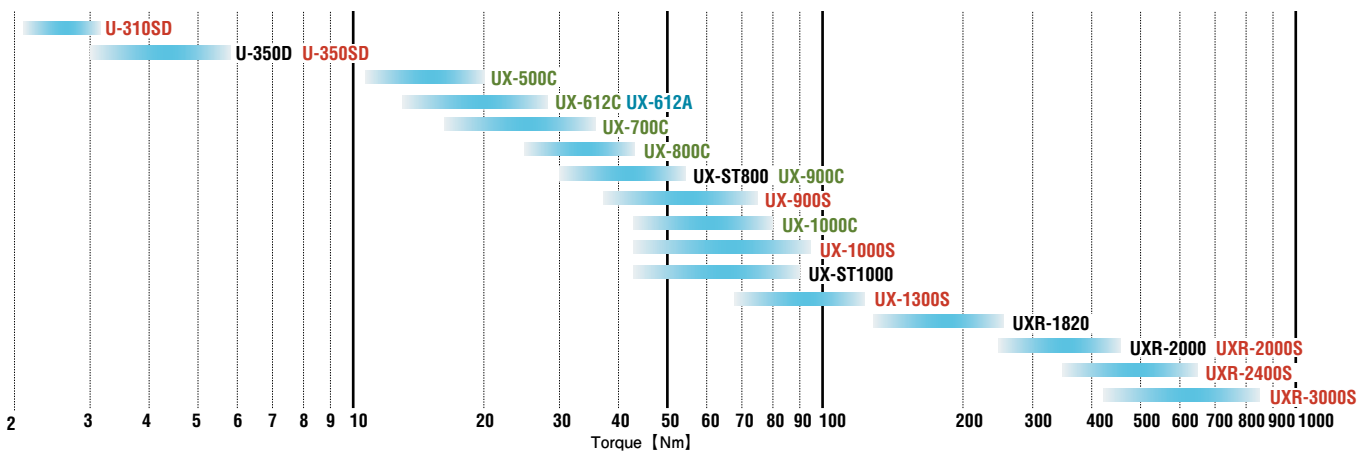

UDBP SERIES [SHUT-OFF TYPE / NON SHUT-OFF TYPE]

High efficient brushless IPM motor has achieved the low reaction force, low vibration and low noise.



UDBP-TA50



UDBP-TA40



UDBP-TA70 (P)



UDBP-A50 (P)
Non-shut off type

Identification Color
[Light Blue]
(A50 & A60)

BOLT & NUT SETTERS

FEATURES

- The pulse unit is connected to the motor unit directly, not through a gear train. This has reduced the noise, vibration, and reaction force against the operator.
- Built-in brushless IPM motor has greatly prolonged the motor longevity, and enabled you to tighten more fasteners than the conventional motor per battery charge.
- Neither the air compressors nor the air hoses are required. It allows the comfortable fastening operations inside narrow or closed work places, and easy layout change of production lines.
- Longevity of Lithium-ion Battery is not affected by repeated recharging after being only partially discharged. It also helps to reduce the tool weight.
- The built-in LED turns on when a tool is triggered. It helps you to install fasteners in dark areas.
- New technology "Auto Relief Function" (PAT.) is employed.

Quick-change driver anvil type

On pulling the sleeve, insert or take off the bit.

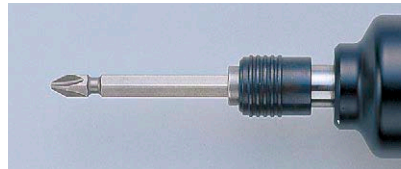
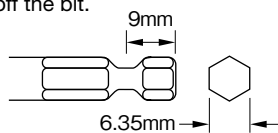

Optional Accessories (Battery, Charger, Protector & Jacket) → P.14

The model name not suffixing (P) is the Quick-change driver anvil type.

Specifications (Shut off Type)

Model	Capacity (Nominal Bolt Size)		Torque Range		Free Speed (Approx.)	Overall Length less Socket or Bit (Approx.)		Weight less Socket or Bit				From Center to Outside (Approx.)		Sq. Drive or Hex. Size		Battery Voltage (Capacity)	Battery Model Number
	mm	in	Nm	ft-lbs		rpm	mm	in	with battery		with no battery		mm	in	mm		
					kg				lb	kg	lb						
UDBP-TA40	5	No.10	4.5-8	3.3-5.9	4800	208	8 3/16	1.4	3.08	1.11	2.44	29.5	1 5/32	6.35Hex.	1/4Hex.	11.1V(1.5Ah)	UB111Li
UDBP-TA40(P)	5	No.10	4.5-8	3.3-5.9	4800	205	8 5/64	1.4	3.08	1.11	2.44	29.5	1 5/32	9.5 sq.	3/8 sq.	11.1V(1.5Ah)	UB111Li
UDBP-TA50	6 - 8	1/4-5/16	6.5-13	4.8-9.6	4800	208	8 3/16	1.4	3.08	1.11	2.44	29.5	1 5/32	6.35Hex.	1/4Hex.	11.1V(1.5Ah)	UB111Li
UDBP-TA50(P)	6 - 8	1/4-5/16	7-15	5.1-11.1	4800	205	8 5/64	1.4	3.08	1.11	2.44	29.5	1 5/32	9.5 sq.	3/8 sq.	11.1V(1.5Ah)	UB111Li
UDBP-TA60	8	5/16	13-26	9.6-19.2	4800	223	8 25/32	1.7	3.74	1.25	2.75	29.5	1 5/32	6.35Hex.	1/4Hex.	22.2V(1.5Ah)	UB222Li
UDBP-TA60(P)	8 - 10	5/16	15-28	11.1-20.7	4800	220	8 11/16	1.7	3.74	1.25	2.75	29.5	1 5/32	9.5 sq.	3/8 sq.	22.2V(1.5Ah)	UB222Li
UDBP-TA70(P)	8 - 10	5/16-13/32	26-47	19.2-34.7	4800	234	9 7/32	2.0	4.4	1.39	3.06	29.5	1 5/32	9.5 sq.	3/8 sq.	33.3V(1.5Ah)	UB333Li

Specifications (Non Shut off Type)

Model	Capacity (Nominal Bolt Size)		Torque Range		Free Speed (Approx.)	Overall Length less Socket or Bit (Approx.)		Weight less Socket or Bit				From Center to Outside (Approx.)		Sq. Drive or Hex. Size		Battery Voltage (Capacity)	Battery Model Number
	mm	in	Nm	ft-lbs		rpm	mm	in	with battery		with no battery		mm	in	mm		
					kg				lb	kg	lb						
UDBP-A50	6-8	1/4-5/16	8-17	5.9-12.6	5300	203	7 63/64	1.4	3.08	1.11	2.44	29.5	1 5/32	6.35Hex.	1/4Hex.	11.1V(1.5Ah)	UB111Li
UDBP-A50(P)	6-8	1/4-5/16	11-20	8.1-14.8	5300	200	7 7/8	1.4	3.08	1.11	2.44	29.5	1 5/32	9.5 sq.	3/8 sq.	11.1V(1.5Ah)	UB111Li
UDBP-A60	8-10	5/16-13/32	17-30	12.6-22.2	4800	218	8 37/64	1.7	3.74	1.25	2.75	29.5	1 5/32	6.35Hex.	1/4Hex.	22.2V(1.5Ah)	UB222Li
UDBP-A60(P)	8-10	5/16-13/32	20-32	14.8-23.7	4800	215	8 15/32	1.7	3.74	1.25	2.75	29.5	1 5/32	9.5 sq.	3/8 sq.	22.2V(1.5Ah)	UB222Li

(P) = Square Anvil Type

UDBP SERIES

Incomplete job detection (TK) [Shut off type]

The tool informs incomplete job with turning red color LED lamp on.



UDBP-TA50 (TK-P)

FEATURES

- Pulling switch lever of tool, red color LED lamp built in the tool turns on.
- When operator releases switch lever before the tool shuts off, red color on LED lamp disappears after 3 seconds.
- When the tool shuts off, buzzer beeps. The color LED lamp turns green from red and inform you that the fastening job has been completed.

(Note) incomplete job detection (When operator releases switch lever and red color LED lamp turns on), then pulling switch lever again to make the tool shuts off, red and green colors LED Lamp turn on at the same time.

Optional Accessories (Battery, Charger, Protector & Jacket) → P.14

Quick-change driver anvil type

On pulling the sleeve, insert or take off the bit.

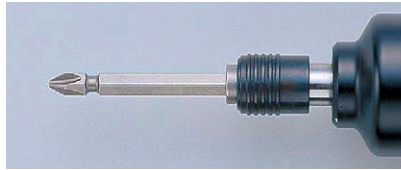
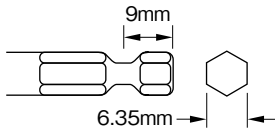

The model name not suffixing (P) is the Quick-change driver anvil type.

Specifications (Shut off Type)

Model	Capacity (Nominal Bolt Size)		Torque Range		Free Speed (Approx.)	Overall Length less Socket or Bit (Approx.)		Weight less Socket or Bit				From Center to Outside (Approx.)		Sq. Drive or Hex. Size		Battery Voltage (Capacity)	Battery Model Number
	mm	in	Nm	ft-lbs	rpm	mm	in	with battery		with no battery		mm	in	mm	in		
								kg	lb	kg	lb						
UDBP-TA40(TK)	5	No.10	4.5-8	3.3-5.9	4800	208	8 3/16	1.4	3.08	1.11	2.44	29.5	1 5/32	6.35Hex.	1/4Hex.	11.1V(1.5Ah)	UB111Li
UDBP-TA40(TK-P)	5	No.10	4.5-8	3.3-5.9	4800	205	8 5/64	1.4	3.08	1.11	2.44	29.5	1 5/32	9.5 sq.	3/8 sq.	11.1V(1.5Ah)	UB111Li
UDBP-TA50(TK)	6 - 8	1/4-5/16	6.5-13	4.8-9.6	4800	208	8 3/16	1.4	3.08	1.11	2.44	29.5	1 5/32	6.35Hex.	1/4Hex.	11.1V(1.5Ah)	UB111Li
UDBP-TA50(TK-P)	6 - 8	1/4-5/16	7-15	5.1-11.1	4800	205	8 5/64	1.4	3.08	1.11	2.44	29.5	1 5/32	9.5 sq.	3/8 sq.	11.1V(1.5Ah)	UB111Li
UDBP-TA60(TK)	8	5/16	13-26	9.6-19.2	4800	223	8 25/32	1.7	3.74	1.25	2.75	29.5	1 5/32	6.35Hex.	1/4Hex.	22.2V(1.5Ah)	UB222Li
UDBP-TA60(TK-P)	8	5/16	15-28	11.1-20.7	4800	220	8 11/16	1.7	3.74	1.25	2.75	29.5	1 5/32	9.5 sq.	3/8 sq.	22.2V(1.5Ah)	UB222Li
UDBP-TA70(TK-P)	8 - 10	5/16-13/32	26-47	19.2-34.7	4800	234	9 7/32	2.0	4.4	1.39	3.06	29.5	1 5/32	9.5 sq.	3/8 sq.	33.3V(1.5Ah)	UB333Li

(P) = Square Anvil Type

UDBP SERIES

OPTION

Battery



The lithium-ion battery is used for UDBP series.

- Its longevity is not affected by repeated recharging after being only partially discharged.
- The battery power indicator provides you with a visual indication to charge the lithium-ion battery.
 - = enough charge
 - = low charge (recharging needed)
 - = very low charge (immediate recharging needed)
- The slide design battery provides the high-energy efficiency in power.

Battery

Model Number	UB111Li	UB222Li	UB333Li
Voltage	11.1V	22.2V	33.3V
Capacity	1.5Ah	1.5Ah	1.5Ah
Weight (Approx.)	0.29Kg	0.45Kg	0.61Kg

Tightening numbers per full charge

Model	Torque(Nm)	Tester & Bolt Size	Battery Model	Tightening Numbers (Approx.)	
UDBP-TA40	7	UFT-6(M6)	UB111Li	Hard Joint	840
UDBP-TA50 · A50	11	UFT-10(M8)	UB111Li	Soft Joint	270
				Hard Joint	580
UDBP-TA50(P) · A50(P)	12.5	UFT-10(M8)	UB111Li	Soft Joint	190
				Hard Joint	580
UDBP-TA60 · A60	24	UFT-10(M10)	UB222Li	Soft Joint	190
				Hard Joint	500
UDBP-TA60(P) · A60(P)	26	UFT-10(M10)	UB222Li	Soft Joint	170
				Hard Joint	500
UDBP-TA70(P)	40	UFT-16(M12)	UB333Li	Soft Joint	170
				Hard Joint	600
				Soft Joint	210

*Torque is set at Hard Joint. Numbers of tightening per charge varies depending on torque level, fastener length and application.

Charger



The tool, charger, and 2 sets of batteries are also available as a set.

Charger

Model Number	UBC
Power Supply	AC100V - AC240V*
Power	100V: 225VA
Consumption	240V: 295VA
Weight (Approx.)	1.6kg
Operating Temperature Range	5-40°C

*Use the power cable which URYU ships with the charger.

Charging Time

Battery Capacity	Time (Approx.)
80%	40 minutes
100%	64 minutes

Protector

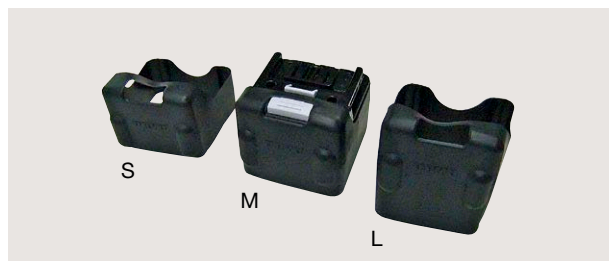

Optional Battery Protectors

	Part Number	Used for
S	863-976-1	UB111Li
M	863-977-1	UB222Li
L	863-978-1	UB333Li

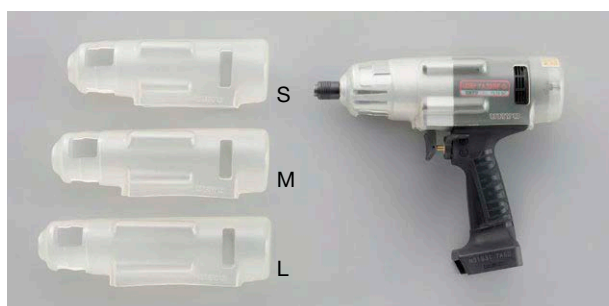

Optional Tool Jackets

	Part Number	Used for
S	863-964-1	UDBP-TA,A50 series
M	863-965-1	UDBP-TA,A60 series
L	863-966-1	UDBP-TA70 series

UDP-TA SERIES [SHUT OFF TYPE]

The shut off type wired electric oil pulse tool without controller. The tool driven by commercial power source.



UDP-TA50D (B)



UDP-TA40 (B)



UDP-TA50 (B-TL)



UDP-TA55 (B-TL)

Top Load Type

FEATURES

- High torque & high efficiency by the IPM motor.
- The Switch Lever switching operation of Low/High speed easily. It realizes speedy fastening operation.
- Built-in cooling fan reduce heating up of tool and increase a number of fastener to be tighten in continuous operation.
- URYU unique newly developed "Auto Relief Function" (PAT.) is adopted.
- Connecting with UTM series (Option), the tool controls a fastening number by counting.
- Buzzer informs operator when the power turns on and the tool correctly shuts off.
- The tool has a function of heat protection. To prevent breakage of the motor, LED lamp (red color · green flashing) turns on when internal temperature of tool extremely goes up.

Quick-change driver anvil type

On pulling the sleeve, insert or take off the bit.

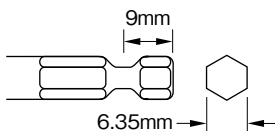

The model name suffixing (D) is the Quick-change driver anvil type.

UDP-TA SYSTEM LAYOUT(115V use)

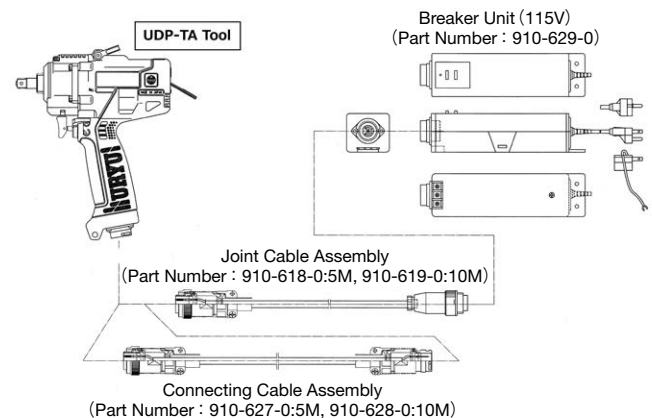

•For 230V use, please procure a down trance locally.

SPECIFICATIONS

Model	Capacity (Nominal Bolt Size)		Torque Range		Free Speed (Approx.)	Overall Length (about)		Weight less Socket or Bit (about)		From Center to Outside (about)		Sq. Drive or Hex. Size	
	mm	in	Nm	ft-lbs	rpm	mm	in	kg	lb	mm	in	mm	in
UDP-TA40(B)/(B-TL)	5	No.10	4.5-8.0	3.3-5.9	3300	179.5	7 1/16	1.35	2.97	29.5	1 5/32	9.5	3/8
UDP-TA50(B)/(B-TL)	6	1/4	7.0-15.5	5.2-11.5	3900	179.5	7 1/16	1.35	2.97	29.5	1 5/32	9.5	3/8
UDP-TA55(B)/(B-TL)	6-8	1/4 - 5/16	12.5-25.0	9.3-18.5	4800	184.5	7 17/64	1.38	3.03	29.5	1 5/32	9.5	3/8
UDP-TA40D(B)/(B-TL)	5	No.10	4.5-8.0	3.3-5.9	3300	182.5	7 3/16	1.35	2.97	29.5	1 5/32	6.35	1/4
UDP-TA50D(B)/(B-TL)	6	1/4	7.0-15.5	5.2-11.5	3900	182.5	7 3/16	1.35	2.97	29.5	1 5/32	6.35	1/4
UDP-TA55D(B)/(B-TL)	6-8	1/4 - 5/16	12.5-25.0	9.3-18.5	4800	187.5	7 3/8	1.38	3.03	29.5	1 5/32	6.35	1/4

(B-TL) is "Top Load" type. Please specify UDP-TA(B) or UDP-TA(B-TL) clearly when you place an order. Specifications may change without prior notice.
"B" stands for "Cable detachable type" and this is our standard.

OIL FILLER FOR PULSE UNIT

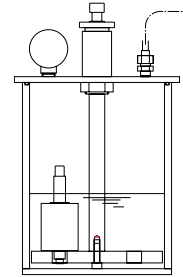

Table 1

Oil Fluid	Q'ty	Part Number
Pulstar Oil 2	1L	998-727-0
	5L	998-728-0
	10L	998-729-0
	20L	998-730-0

FEATURES

The new **UOF-2** eliminates troublesome process of oil-filling procedure repeated at previous model UOF-1 due to employment of the powerful vacuuming system.

Use Pulstar Oil 2 (see table 1) and do not substitute any other fluid.

You can choose the Oil Filler from the below choices.

Part Number	Description
878-945-1	Complete Set for Oil Filler (with Vacuum Pump and Oil Filler Tank)
878-955-1	Oil Filler without Vacuum Pump

Electric control system

SUPER "INTELEC" SERIES

URYU Electric control system series running with more precise control meets a scene requiring accurate and delicate control.

POINT 1

Control a tool easily by a controller.

- Programming is easy on front panel. You can also upload your program from PC. (The exclusive setup software is necessary)
- Counting a number of fastener and various error detection functions are equipped.
- Controller meets various work condition, maximum 8 different kinds works can be set.
- A fastening number and a pulse number can be controlled.
- Fastening torque result and torque waveform can be shown.
- Standard deviations, Cp value, Cpk value can be analyzed instantly from the stored data within the controller and you can graph the statistical data.
- Check of Input/Output and display of errors can be confirmed with beep sound and display on PC or Front panel of controller. (For touch panel type only)

POINT 2

Function on setup software with PC.

- Transmit and receive setting values
- Receive and store fastening results
- Receive and store waveform data
- Receive and store statistical data
- I / O check

POINT 3

Self-checking function

When the power turns on, self-checking function automatically runs as ROM→RAM→A/D→Filter Check→ZERO CAL Check and etc.

POINT 4

Ethernet (TCP/IP) capable

- When the dedicated setup software is installed to PC, setting parameters can be transmitted and received between controller and PC, fastening result/waveform data can be received from controller.
- When a controller is connected with a host computer to control an assembly line, the controller receive a fastening instruction from the host computer and return the fastening result with the instruction to host computer.

Controller \ Tool		UDP-MC SERIES ▶ P.19	UAAMC SERIES ▶ P.24	UAMC SERIES ▶ P.26	UXR-MC SERIES ▶ P.27
UECP SERIES ▶ P.18		●	—	—	—
UEC-4800 (SD) SERIES ▶ P.20		—	●	●	●
UEC-5500 ▶ P.22		—	—	●	●

UECP SERIES

The UECP series Controller becomes one unit combined driver unit to drive UDP-MC series electric oil pulse tools and multi-function controller of UEC-4800 to control a transducerized tool.

BOLT & NUT SETTERS



*Joint Cable Assembly is necessary to connect tool with controller
 For UDP-A60 · A80 · A100MC 910-517-0: 5M / 910-518-0: 10M
 For UDP-A120MC 910-567-0: 5M / 910-568-0: 10M

UECP SERIES SPECIFICATIONS

POWER SUPPLY	UECP-4800A: AC115V UEC-4800E: AC230V UECP-4810A: AC115V UEC-4810E: AC230V
POWER FREQUENCY	50 / 60 Hz
NOISE PROTECTION	1000V 1μS (according to noise simulator)
INSULATION PROTECTION	DC500V over 10MΩ
AMBIENT TEMPERATURE	0 ~ 50°C (non-freezing)
AMBIENT HUMIDITY	90% RH or less (no dew)
WEIGHT	11.30 kg
DIMENSIONS	265 (D) × 222 (W) × 200 (H)
MAIN FUNCTIONS	Torque control, Torque monitor Fastener number count
PARAMETER SETUP	Manual input on front LCD panel By PC (with setup software)
DISPLAY	Torque resolution ±2048 (12 bit by A/D use)
	LCD type LCD (20 letters × 4 lines)
	Work number, Bolt count number, Tightening time and Pulse blow number 1-digit Digital Display (DPM) Work number displayed 4-digit Digital Display (DPM) Torque reading displayed
LED	Total Lamp (for Count Judgment) : OK (green) / NOK (red) Torque Lamp (for Torque Judgment) : LOW (yellow) / OK (green) / HIGH (red)
INPUT TERMINAL SIGNAL	Operation Voltage/Current : DC24V / about 10mA 6 terminals available (programmable) Note: Contact input necessary
OUTPUT TERMINAL SIGNAL	Contact Capacity : DC30V, 1A 6 terminals available (programmable), VALVE
OPTION	Setting PC Cable (Straight) Part Number : 910-219-0

UECP-4800	UDP-A60 · A80 · A100 MC Series
UECP-4810	UDP-A60 · A80 · A100 · A120 MC Series

UECP Series System Layout

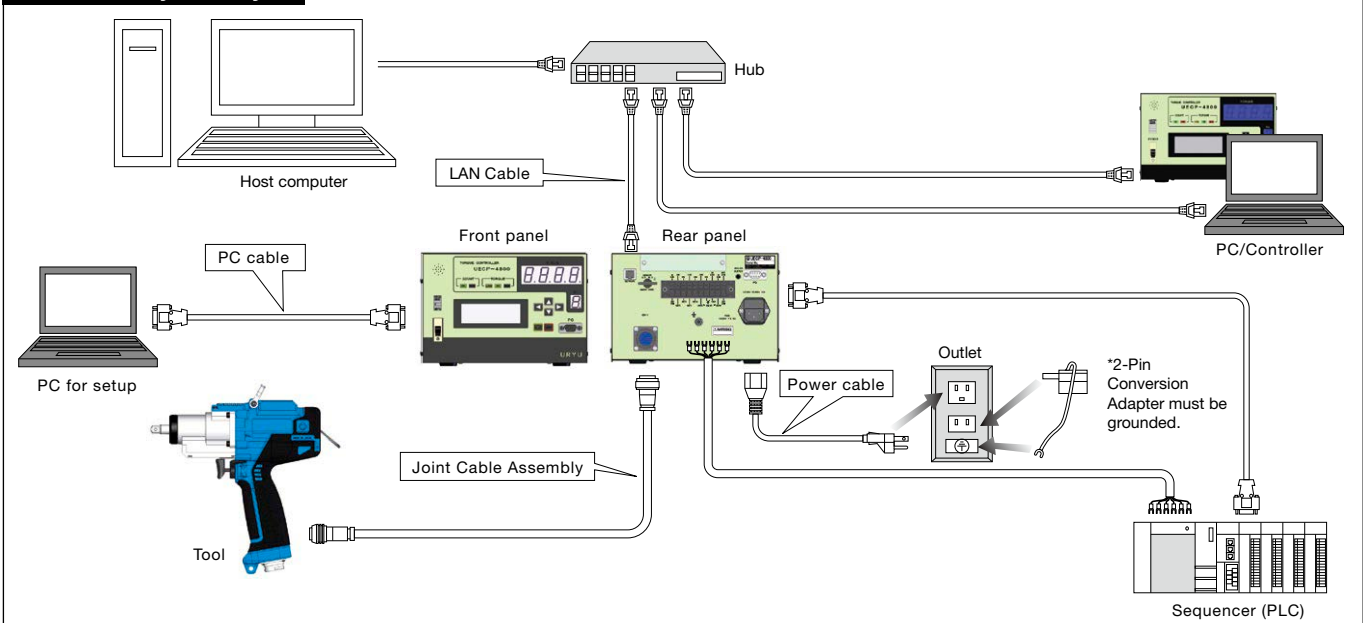

UDP-MC SERIES

Exquisite Range of Torque.
Fastening with high efficiency & high accuracy.



UDP-A60LMC



UDP-A60MC



UDP-A100MC
UDP-A120MC



UDP-A80MC



Top Load Type
UDP-A60LMC (TL)

FEATURES

- URYU's unique non-contact Magnetostrictive transducer incorporated.
- The UDP tool is driven by commercial electricity. This helps you build an assembly line easily and adjust it flexibly to the layout change.
- High Power and High efficiency adopted by IPM motor. (except for A100MC/A120MC)
- Cooling fan is activated automatically when pulling the throttle trigger, which contributes to heat reduction and increase number of fastening.
- URYU know-how acquired from the pneumatic oil-pulse tool development, and newly developed "Auto Relief Function" (PAT.) is adopted.
- The intelligence of UDP-MC tool stops operation immediately to protect the operator from the failure including overloaded operation, short circuit, and broken wire, which minimizes the possible influence over operator and shop floor.

[FUNCTIONS]

- Motor speed/current is programmable.
 - Motor current can be set in 4 steps
 - Motor rotational speed can be set in 100 rpm increments (by the 2-step fastening, torque spike at bolt seating is inhibited, and make it possible to cover the wider torque range.)
- The functions of various fastening error detections and fastener number count down assure your operations.
- Makes setup or changeover of fastening torque and fastening number count.
- Tool's maintenance is possible by counting both total cycle numbers (how many fasteners) and/or total pulse numbers.
- Input/Output check and error messages can be checked from your PC screen or the front panel of UECP Series with buzzer sounding.
- Can set up and monitor various control values and setting values either on the front panel or on your PC screen.
- Ethernet (TCP/IP) capable. Upload and receipt of the setting values, upload of the fastening result/waveform data through PC software.

Electric Oil-Pulse Tool UDP-MC Series

Model	Capacity (Nominal Bolt Size)		Torque Range		Free Speed (Approx.) rpm	Overall Length (about)		Weight less Socket or Bit (about)		From Center to Outside (about)		Sq. Drive or Hex. Size	
	mm	in	Nm	ft-lbs		mm	in	kg	lb	mm	in	mm	in
UDP-A60LMC, (TL)	5-6	NO.10-1/4	4-20	3.0-14.8	4800	214	8 27/64	1.53	3.37	29.5	1 5/32	9.5	3/8
UDP-A60MC, (TL)	6-8	1/4 -5/16	5-25	3.7-18.5	4800	214	8 27/64	1.53	3.37	29.5	1 5/32	9.5	3/8
UDP-A80MC, (TL)	8-12	5/16-1/2	25-55	18.5-40.5	4800	242	9 33/64	1.78	3.92	29.5	1 5/32	9.5	3/8
UDP-A100MC, (TL)	10-12	3/8 -1/2	45-100	33.3-74.0	4800	248	9 49/64	2.85	6.27	34.5	1 23/64	12.7	1/2
UDP-A120MC, (TL)	10-12	3/8 -1/2	55-120	40.5-88.4	4800	248	9 49/64	2.85	6.27	34.5	1 23/64	12.7	1/2

UEC SERIES (Single Spindle Connection)

UEC-4800TP(SD) / UEC-4800TP(SD-ANGLE)

The Touch Panel type visualizes all fastening results.



FEATURES

- Ethernet(TCP/IP) capable.
- You can see Torque Wave data on both front touch panel and PC.

[Top Screen]



[Wave form Screen]

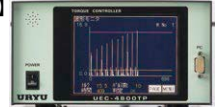

- You can choose between Torque Control/Monitoring. You can detect various fastening errors and control the job with fastening counter.
- UEC-4800TPA/E(SD) Series can be used for 8 different fastening applications.
- Front panel, PC display or buzzer will tell you Input/Output(terminal blocks & tool wiring) checks and errors.
- UEC-4800TPA/E(SD) Series memorizes max. 4,550 fastening data(max. 1,900 fastening data when ID data is included). Standard deviations, Cp value, Cpk value can be analyzed instantly from the stored data within the controller. When you connect UEC-4800TPA/E(SD) Series to PC, you can graph the statistical data.
- By using Input/Output terminals UEC-4800TPA/E(SD) Series can be interlocked with the production line.

UEC-4800 (SD) / UEC-4800 (SD-ANGLE)

Cost-Effective LCD-Panel Available



FEATURES

- LCD-Panel type is available for more cost effective.
- Setting parameters can be put into the controller on the front panel as well as PC.

[FUNCTIONS]

- You can see Torque Wave data on PC connected to LCD-Panel type.

*The other features and functions are the same from UEC-4800TPA/E(SD) and UEC-4800TPA/E(SD-ANGLE).

SPECIFICATIONS

Models	UEC-4800TPA/E (SD)	UEC-4800TPA/E (SD-ANGLE)	UEC-4800A/E (SD)	UEC-4800A/E (SD-ANGLE)
POWER SUPPLY	AC100 ~ 240V ±10%		AC100 ~ 240V ±10%	
POWER FREQUENCY	50/60 Hz		50/60 Hz	
NOISE PROTECTION	1000V 1μS (according to noise simulator)		1000V 1μS (according to noise simulator)	
INSULATION PROTECTION	DC500V over 10MΩ		DC500V over 10MΩ	
AMBIENT TEMPERATURE	0 ~ 50°C (non-freezing)		0 ~ 50°C (non-freezing)	
AMBIENT HUMIDITY	Under 90%RH (no dew)		Under 90%RH (no dew)	
POWER CONSUMPTION	Approx. 30VA		Approx. 30VA	
WEIGHT	Approx. 3.6 kg		Approx. 3.6 kg	
DIMENSIONS	265(D) x 222(W) x 120(H)		265(D) x 222(W) x 120(H)	
MAIN FUNCTIONS	Torque Monitoring / Control + Fastening Counter		Torque Monitoring / Control + Fastening Counter	
ANGLE MONITORING	—		—	
PARAMETER SETUP	Manual Input on Front Touch Panel		Manual Input on Front LCD Panel	
	Personal Computer (with setup software)		Personal Computer (with setup software)	
DISPLAY	Torque Resolution ±2048 (12Bit A/D) 320 x 240 dot 25 characters x 15 lines		Torque Resolution ±2048 (12Bit A/D) LCD : 20 characters x 4 lines Contents : WORK NO. / FASTENING COUNT DOWN NO. / FASTENING TIME / PULSE NO. 1-digit digital display (DPM) : WORK NO. 4-digit digital display (DPM) : TORQUE	
LED	COUNT Lamp : OK (Green) / NOK (Red)		COUNT Lamp : OK (Green) / NOK (Red)	
	TORQUE Lamp : LOW (Yellow) / OK (Green) / HIGH (RED)		TORQUE Lamp : LOW (Yellow) / OK (Green) / HIGH (RED)	
INPUT TERMINAL SIGNAL	Operation Voltage/Current : DC24V/aprox. 10mA 6 terminals (free format), VALVE		Operation Voltage/Current : DC24V/aprox. 10mA 6 terminals (free format), VALVE	
OUTPUT TERMINAL SIGNAL	Contact Capacity : AC:125V, 0.3A, DC:30V, 1A 6 terminals (free format), VALVE		Contact Capacity : AC:125V, 0.3A, DC:30V, 1A 6 terminals (free format), VALVE	
OPTION	Setting PC Cable (Straight) Part Number : 910-219-0			

Used with

Magnetostrictive Sensor Pulse Wrench	UAAMC Series / UAMC Series / UXR-MC Series
Strain-Gauge Sensor Pneumatic Nutrunner	UAN-RM Series

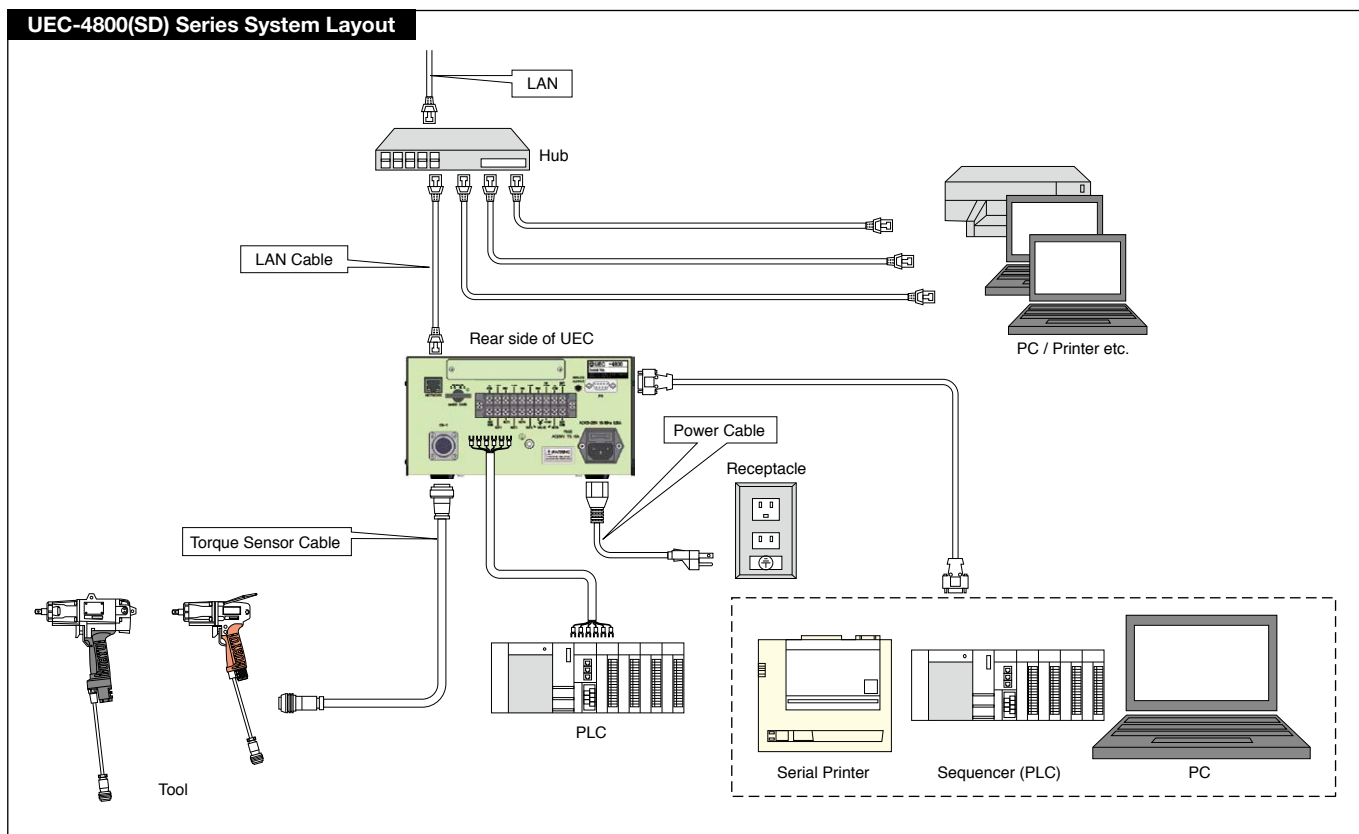

UEC SERIES (Multi Spindle Connection)

UEC-5500

Multi-function controller which can control 4-spindles simultaneously. UEC-5500 controls various error detections, the number of fasteners and pulse numbers for 4 different tools in one controller.



Used with

Magnetostrictive Sensor Pulse Wrench	UAMC Series / UXR-MC Series
Strain-Gauge Sensor Pneumatic Nutrunner	UAN-RM Series

*Key Pad (910-208-0) and Key Pad Cable (910-206-0) are optional items, so please purchase them separately.

FEATURES

- UEC-5500 can control max. 4 different transducerized tools simultaneously.
- UEC-5500 can be used with various type of transducerized tools.
 - Oil-Pulse Tools fitted with a brushless type Magnetostrictive Transducer.
 - UAMC Series, UXR-MC Series
 - Pneumatic Nutrunners fitted with a Strain-Gauged Transducer.
 - UAN-RM Series
- High Reliable Torque Control & Monitor.
- Easy Programming with a Removable Key Pad. You can also upload the fastening programmes from PC.
- Ethernet(TCP/IP) capable.

[FUNCTIONS]

- You can choose between Torque Control and Monitor. You can detect various errors and control the job with fastening counter.
- You can see 'Torque wave Data' on PC.
- Makes setup or changeover of fastening torque and fastening number count for 8 different fastening applications.
- Input/Output check and error messages can be checked from your PC screen or the front panel of UEC-5500 with buzzer sounding.
- For Oil-Pulse Tools, tool maintenance can be determined by the total numbers of fasteners as well as total pulse numbers.
- UEC-5500 memorizes max. 20,000 fastening data per spindle. By connecting to PC, you can download the stored data to your PC for statistical analysis of mean, σ , 3σ / mean, CP, and CPK. You can also graph the statistical data.
- By using Input / Output terminals UEC-5500 can be interlocked with the production line.

UEC-5500A/E SPECIFICATIONS

POWER SUPPLY	AC100 ~ 240V ±10%
POWER FREQUENCY	50 / 60 Hz
NOISE PROTECTION	1000V 1μS (according to noise simulator)
INSULATION PROTECTION	DC500V over 10MΩ
AMBIENT TEMPERATURE	0 ~ 50°C (non-freezing)
AMBIENT HUMIDITY	Under 90%RH (no dew)
POWER CONSUMPTION	Approx. 50VA
WEIGHT	Approx. 3.6 kg
DIMENSIONS	240(D) × 270(W) × 115(H)
MAIN FUNCTIONS	Torque Monitoring / Control + Fastening Counter
PARAMETER SETUP	Removable Key Pad Personal Computer (with setup software)
DISPLAY	Torque Resolution ±2048 (12Bit A/D) 4-digit digital display : TORQUE 2-digit digital display : FASTENING COUNT DOWN NO. 1-digit digital display (small) × 4 : WORK NO. 1-digit digital display (large) × 4 : SPINDLE NO.
LED	Each Spindle's COUNT Lamp : OK (Green) / NOK (Red) TORQUE Lamp : LOW (Yellow) / OK (Green) / HIGH (RED)
INPUT TERMINAL SIGNAL	Drive by Electric Current Input (Photo Coupler Insulation) Voltage : DC24V Insulation Resistance : 4.7KΩ 12 terminals (free format)
OUTPUT TERMINAL SIGNAL	Contact Capacity : AC:125V, 0.3A, DC:30V, 1A 8 terminals (free format), VALVE, +24V
OPTION	Setting PC Cable(Straight) Part Number : 910-219-0

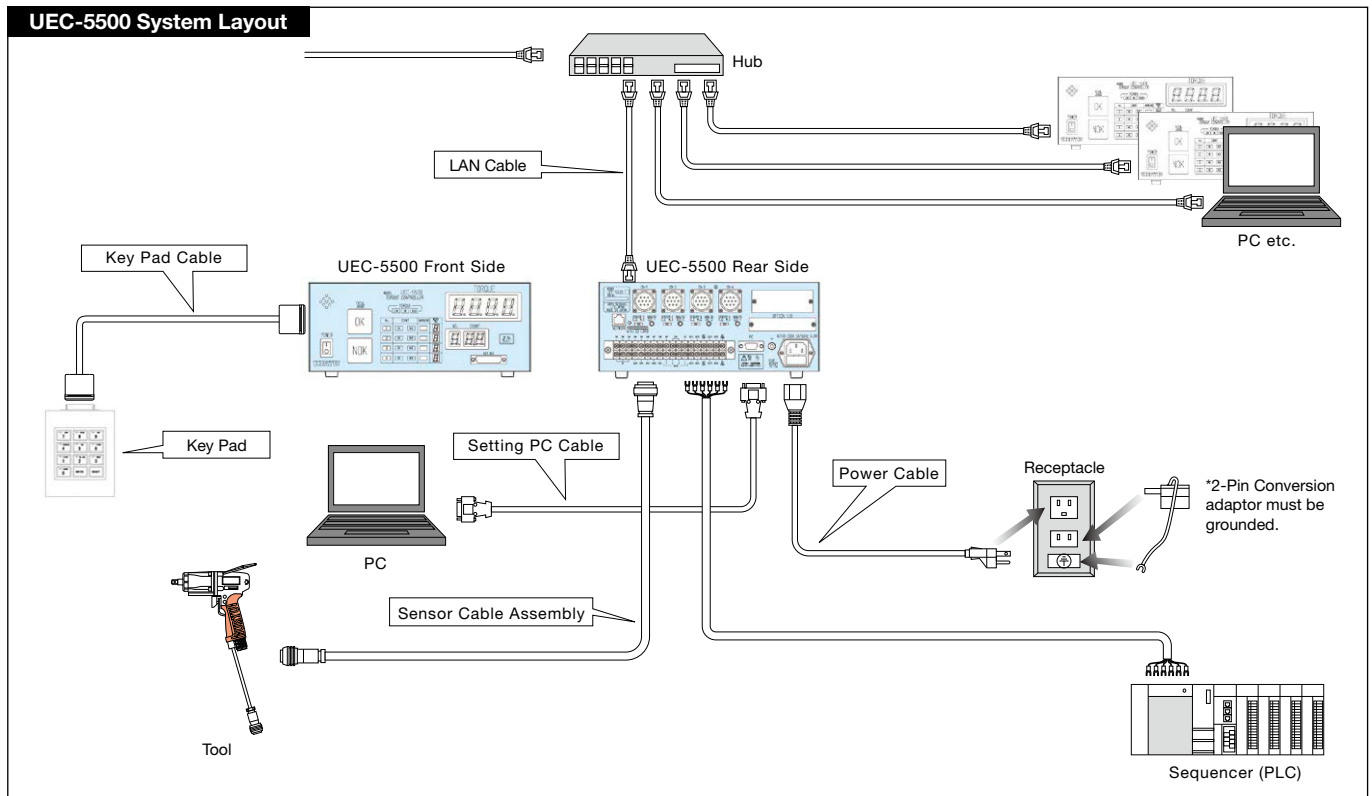

UAAMC SERIES

Various fastening errors such as double-hit, cross-thread, foreign objects insertion are detectable. Fastening quality improved by angle monitoring function provides you with enhanced reliability.



UA400AMC



UA500AMC



UA600AMC



UA700AMC



UA1300AMC

FEATURES

- UAAMC series are capable of angle monitoring in addition to the torque control/monitoring from UAMC series. It enables you to get double-hit, cross-thread, foreign object insertion and so forth by angle monitoring, and improve the fastening quality.
- URYU independent new technology "Auto Relief Function" (PAT.) is adopted.

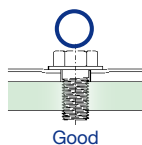

Good

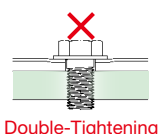

Double-Tightening

Double-Tightening :

Detectable as the torque increases, while the free run angle lacks.

- Free Run Angle NG

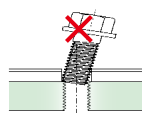

Cross Thread

Cross Thread :

Detectable as the fastening angle gets too high.

- Angle NG

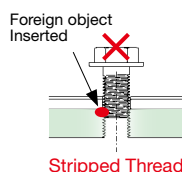

Stripped Thread

Stripped Thread/Seized Thread :

Detectable as the torque does not increase and the fastening angle gets too high.

- Angle NG

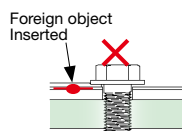

Seized Thread

Foreign Object Inserted :

Detectable as the torque does not increase and the fastening angle gets too high.

- Angle NG

SPECIFICATIONS

Recommended Air Pressure: 0.5MPa (72psi) - 0.6MPa (85psi)

Model	Capacity (Nominal Bolt Size)		Torque Range				Free Speed (Approx.) rpm		Overall Length (about)		Weight less Socket or Bit (about)		From Center to Outside (about)		Sq. Drive or Hex. Size		Average Air Consumption	
			0.5MPa		0.6MPa													
	mm	in	Nm	ft-lbs	Nm	ft-lbs	0.5MPa	0.6MPa	mm	in	kg	lb	mm	in	mm	in	m ³ /min	ft ³ /min
UA400AMC	6	1/4	5-11	3.7-8.1	7-13	5.2-9.6	2900	3200	193	7 19/32	1.35	2.97	28.0	1 7/64	9.5	3/8	0.20	7.0
UA500AMC	6-8	1/4-5/16	9-20	6.6-14.8	11-25	8.1-18.4	3600	3800	193	7 19/32	1.35	2.97	28.0	1 7/64	9.5	3/8	0.25	8.8
UA600AMC	8	5/16	16-30	11.8-22.1	18-38	13.3-28.0	4100	4300	198.5	7 13/16	1.4	3.08	28.0	1 7/64	9.5	3/8	0.40	14.0
UA700AMC	8-10	5/16-3/8	25-40	18.4-29.5	30-50	22.1-36.9	5900	6200	207.5	8 11/64	1.5	3.3	28.5	1 1/8	9.5	3/8	0.45	15.8
UA800AMC *	10	3/8	35-50	25.8-36.9	40-60	29.5-44.3	5000	5300	215.5	8 31/64	1.7	3.74	29.0	1 9/64	9.5	3/8	0.48	16.8
UA900AMC	10-12	3/8-1/2	35-65	25.8-47.9	40-80	29.5-59.0	5700	6000	227.5	8 61/64	2.15	4.73	28.0	1 7/64	12.7	1/2	0.53	18.6
UA1000AMC	12	1/2	45-75	33.2-55.3	50-90	36.9-66.4	5200	5500	235.0	9 1/4	2.45	5.39	30.0	1 3/16	12.7	1/2	0.55	19.3
UA1300AMC	14	9/16	70-110	51.6-81.1	85-130	62.7-95.9	4400	4600	256.5	10 3/32	3.25	7.15	36.0	1 27/64	12.7	1/2	0.73	25.6

Air Inlet size : NPT1/4" Air Hose size : 10mm×6.5mm×5m for UA400AMC and UA500AMC 12mm×8.0mm×5m for UA600AMC~UA1000AMC 16mm×11.0mm×5m for UA1300AMC
 *Please refrain from using UA800AMC at around max. torque as it is developed to aim at torque output between UA700AMC and UA900AMC.

System Layout

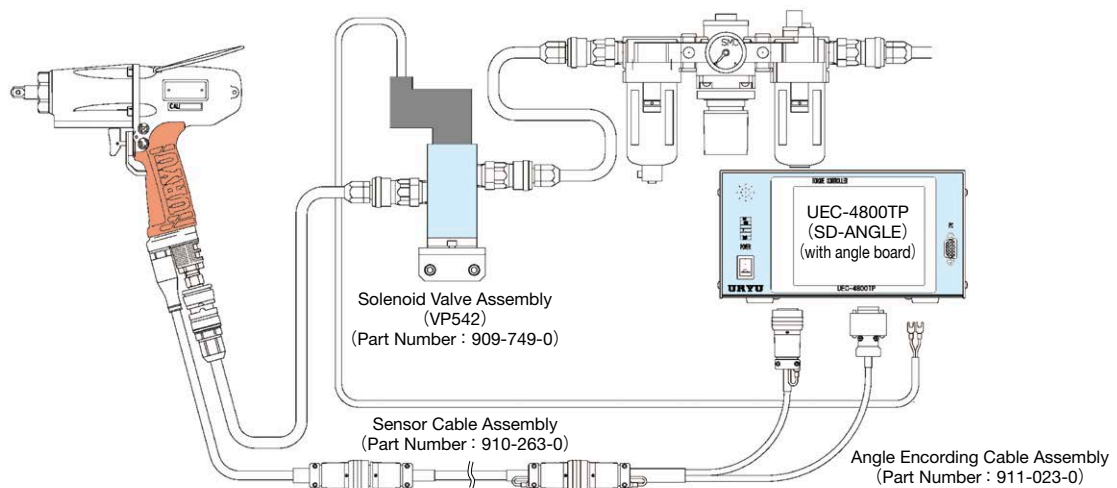

*Angle board should be mounted on UEC-4800(SD)series for angle detection.

OPTION

Cable Hose Assembly

Cable Hose Assembly is a combination hose of Air Hose and Sensor Cable Assembly which can be used for the connection between MC/EC wrench and Controller/Solenoid Valve Assembly.

Please ask your local URYU distributor for details of corresponding models, size, hose inside diameter and so on.

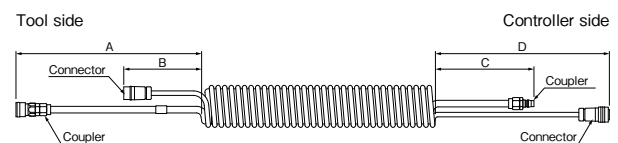

Parts Name	Part Number	Hose Color	Dimensions (mm)						Hose inside Diameter (mm)
			A	B	Maximum Coiled Range of use	Minimum Coiled Length	C	D	
Cable Hose Assembly $\phi 12 \times \phi 45 \times 27$ (R) 1.1	935-280-0	Red	1300	1100	2200	350	300	500	8
Cable Hose Assembly $\phi 12 \times \phi 75 \times 38$ (GR)	935-276-0	Gray	400	200	5800	480	200	400	8
Cable Hose Assembly $\phi 12 \times \phi 45 \times 28$ (GR)	935-275-0	Gray	1000	700	2400	370	300	500	8

UAMC SERIES

In pursuit of high-efficiency, high-accuracy and durability, we have adopted auto-relief function*, which shortens the fastening time and improve the fastening efficiency.

*Refer to page 6 for more understanding of "auto-relief function" (PAT).

BOLT & NUT SETTERS



UA40MC



UA70SMC



UA50MC



UA60MC



UA150MC



UA40SMC



UA50SMC



UA60SMC

FEATURES

- URYU independent new technology "Auto Relief Function" (PAT.) is adopted.
- In addition to the protective handgrip, full-cover Tool Jacket is equipped as standard, which protects tools and reduces the damage to the work.
- Ergonomic light weight & compact design ensures less operators fatigue.

System Layout

When using terminal (UEC-4800 TP (SD))

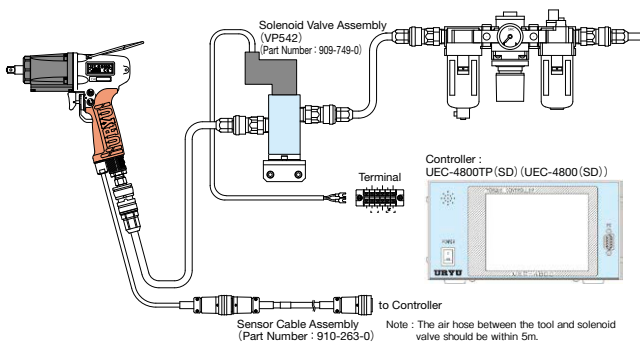

When not using terminal (UEC-4800(SD))

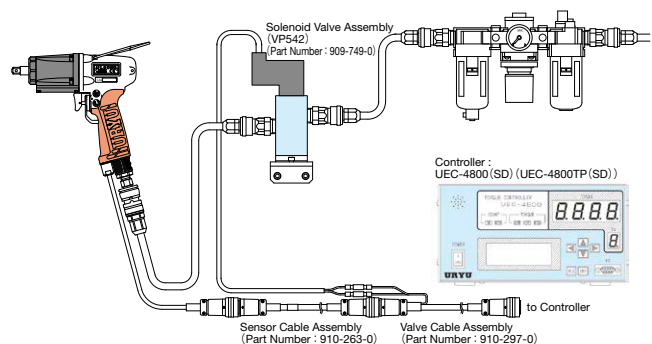

Quick-change driver anvil type

On pulling the sleeve, insert or take off the bit.

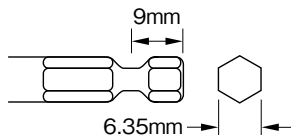

The model name suffixing (D) is the Quick-change driver anvil type.

SPECIFICATIONS (PISTOL TYPE)

Recommended Air Pressure: 0.5MPa (72psi) - 0.6MPa (85psi)

Model	Capacity (Nominal Bolt Size)		Torque Range				Free Speed (Approx.) rpm		Overall Length (about)		Weight less Socket or Bit (about)		From Center to Outside (about)		Sq. Drive or Hex. Size		Average Air Consumption	
			0.5MPa		0.6MPa		0.5MPa	0.6MPa										
	mm	in	Nm	ft-lbs	Nm	ft-lbs	0.5MPa	0.6MPa	mm	in	kg	lb	mm	in	mm	in	m ³ /min	ft ³ /min
UA40MC	6	1/4	4.9-9.3	3.6-6.8	6.8-12.0	5.0-8.8	3300	3600	170	6 11/16	1.1	2.42	26	1 1/32	9.5	3/8	0.20	7.0
UA40DMC	6	1/4	4.9-9.3	3.6-6.8	6.8-12.0	5.0-8.8	3300	3600	170	6 11/16	1.1	2.42	26	1 1/32	6.35	1/4	0.20	7.0
UA50MC	6-8	1/4	11.9-22.5	8.8-16.6	16.6-29.0	12.2-21.4	3900	4200	170	6 11/16	1.1	2.42	26	1 1/32	9.5	3/8	0.25	8.8
UA50DMC	6-8	1/4	11.9-22.5	8.8-16.6	16.6-29.0	12.2-21.4	3900	4200	170	6 11/16	1.1	2.42	26	1 1/32	6.35	1/4	0.25	8.8
UA60MC	8	5/16	18.1-34.2	13.3-25.3	25.1-44.0	18.5-32.5	4800	5000	175	6 57/64	1.14	2.51	26	1 1/32	9.5	3/8	0.40	14.0
UA70MC	8-10	5/16-3/8	20.5-38.9	15.1-28.7	28.5-50.0	21.0-37.0	5500	5700	187	7 23/64	1.24	2.73	26	1 1/32	9.5	3/8	0.45	15.8
UA80MC*	10	3/8-1/2	30.0-50.0	22.2-37.0	40.0-60.0	29.6-44.4	5700	6000	195	7 43/64	1.55	3.41	26	1 1/32	9.5	3/8	0.48	16.8
UA90MC	10-12	3/8-1/2	32.8-62.2	24.2-46.0	45.7-80.0	33.8-59.2	5700	6000	203	7 63/64	1.7	3.74	28	1 7/64	12.7	1/2	0.53	18.6
UA100MC	12	1/2	36.9-70.0	27.3-51.8	51.4-90.0	38.0-66.6	4900	5200	215	8 15/32	2.05	4.51	30	1 3/16	12.7	1/2	0.55	19.3
UA130MC	14	9/16	53.4-101.0	39.5-74.7	74.2-130.0	54.9-96.2	4300	4500	233	9 11/64	2.8	6.16	36	1 27/64	12.7	1/2	0.73	25.6
UA150MC	16	5/8	140.0-200.0	104.0-148.0	150.0-220.0	111.0-163.0	4100	4250	251	9 7/8	4.0	8.80	40	1 37/64	19.0	3/4	0.70	24.7

Air Inlet size : NPT1/4" Air Hose size : 6.5mm for UA40MC~50MC 8.0mm for UA60MC~100MC 11.0mm for UA130MC and UA150MC

*Please refrain from using UA80MC at around max. torque as it is developed to aim at torque output between UA70MC and UA90MC.

SPECIFICATIONS (STRAIGHT TYPE) OK / NOK LED indicator equipped.

Recommended Air Pressure: 0.5MPa (72psi) - 0.6MPa (85psi)

Model	Capacity (Nominal Bolt Size)		Torque Range				Free Speed (Approx.) rpm		Overall Length (about)		Weight less Socket or Bit (about)		From Center to Outside (about)		Sq. Drive or Hex. Size		Average Air Consumption	
			0.5MPa		0.6MPa		0.5MPa	0.6MPa										
	mm	in	Nm	ft-lbs	Nm	ft-lbs	0.5MPa	0.6MPa	mm	in	kg	lb	mm	in	mm	in	m ³ /min	ft ³ /min
UA40SMC	6	1/4	5-11	3.7-8.1	7-13	5.2-9.6	3300	3600	246	9 11/16	1.22	2.68	26	1 1/32	9.5	3/8	0.20	7.0
UA40SDMC	6	1/4	4.5-9.5	3.3-7.0	5-12	3.7-8.9	3300	3600	246	9 11/16	1.22	2.68	26	1 1/32	6.35	1/4	0.20	7.0
UA50SMC	6-8	1/4-5/16	9-20	6.7-14.8	11-25	8.1-18.5	4800	5000	246	9 11/16	1.23	2.70	26	1 1/32	9.5	3/8	0.25	8.8
UA50SDMC	6-8	1/4-5/16	8-18	5.9-13.3	9-23	6.7-17.0	4800	5000	246	9 11/16	1.23	2.70	26	1 1/32	6.35	1/4	0.25	8.8
UA60SMC	8	5/16	16-30	11.8-22.2	18-38	13.3-28.1	4500	4600	252	9 61/64	1.30	2.86	26	1 1/32	9.5	3/8	0.40	14.0
UA60SDMC	8	5/16	14-27	10.4-20.0	16-34	11.8-25.2	4500	4600	252	9 61/64	1.30	2.86	26	1 1/32	6.35	1/4	0.40	14.0
UA70SMC	8-10	5/16-3/8	25-40	18.8-29.6	30-50	22.2-37.0	5400	5700	265	10 7/16	1.39	3.05	26	1 1/32	9.5	3/8	0.45	15.8

Air Inlet size : NPT1/4" Air Hose size : 10mmx6.5mmx5m for UA40SMC~50SMC 12mmx8.0mmx5m for UA60SMC and UA70SMC

UXR-MC SERIES

SPECIFICATIONS

Recommended Air Pressure : 0.6MPa (85psi)

Model	Capacity (Nominal Bolt Size)		Torque Range				Free Speed (Approx.) rpm		Overall Length (about)		Weight less Socket or Bit (about)		From Center to Outside (about)		Sq. Drive or Hex. Size		Average Air Consumption	
			0.5MPa		0.6MPa		0.5MPa	0.6MPa										
	mm	in	Nm	ft-lbs	Nm	ft-lbs	0.5MPa	0.6MPa	mm	in	kg	lb	mm	in	mm	in	m ³ /min	ft ³ /min
UXR-1820MC	18	3/4	140-220	102.7-162.0	160-250	117.8-183.7	4400	4600	322	12 43/64	5.50	12.3	42.0	1 21/32	19.0	3/4	0.70	24.7
UXR-2000MC	20	3/4	200-350	147.6-258.2	250-400	184.4-295.1	4600	4800	355	13 31/32	8.00	17.6	47.0	1 21/32	19.0	3/4	0.95	33.6
UXR-2400SMC	24	7/8	300-550	221.3-405.8	350-600	258.2-442.7	3100	3300	457	17 63/64	12.5	27.6	55.0	1 11/64	25.4	1	1.00	35.3

*External Solenoid Valve is required.

Air Inlet size : NPT3/8" for UXR-1820MC & UXR-2000MC NPT1/2" for UXR-2400SMC

Air Hose size : 12.7mm (1/2") for UXR-1820MC~UXR-2400SMC

Inside Trigger is available for UXR-2400SMC

TORQUE CONTROL ELECTRIC ANGLE NUTRUNNERS

URYU has developed UAN-F130 series Electric Angle Nutrunner by merging the fastening technology of pneumatic tools in high speed servo motor angle nutrunner. It enables high accurate fastening with compact design controller.

FEATURES

- Wide range speed control due to high speed motor.
- Data communication by interface to external systems via built-in RS232C board.

[FUNCTIONS]

- High accurate fastening with Torque/Angle control.
- Display Torque/Angle curve (displays these curves on front touch panel in touch panel type controller).
- Up to 16 multi-steps fastening by programming with controller or through setup software of PC.
- Data storage capacity: 12,000 data points.
- Interlock with line is possible due to terminals available in the rear panel.



CONTROLLER : UEC-160AN / UEC-TP160AN



UEC-160AN
(7-segment Type)

UEC-TP160AN
(Touch Panel Type)

SPECIFICATIONS

Models	UEC-160AN	UEC-TP160AN
Power supply	Single phase AC100 - 230V	Single phase AC100 - 230V
Power frequency	50/60Hz	50/60Hz
Ambient temperature	0 - 45 (no dew)	0 - 45 (no dew)
Ambient Humidity	30 - 90% (no dew)	30 - 90% (no dew)
Consumption	Approx. 80W	Approx. 80W
Weight	16.60 kgs.	16.90 kgs.
Dimensions (mm)	350Dx170Wx442H	350Dx170Wx442H
Main functions	Either of torque control and angle monitor, or angle control and torque monitor	Either of torque control and angle monitor, or angle control and torque monitor
Parameter set	Pressing front key pads, CAL, RES, MODE, SET, ▽, △, ◀, ▶, or from your PC (software required)	Front touch panel setting or from your PC (software required)
Front display panel	4-digit: setting value, torque/angle 2-digit:(left) Work number 2-digit:(right) Count number	25 letters and 15 lines 4-digit: Torque/Count (orange)
Lamp display	Total OK (green), NOK (red) Judgment TORQUE/COUNT(orange)	Total OK (green), NOK (red) Judgment TORQUE/COUNT(orange)
Option	Setting PC Cable (Crossover) Part Number : 910-020-0	

TOOL : UAN-F130 SERIES



UAN-F130-025



UAN-F130-060



UAN-F130-120

SPECIFICATIONS

Model	Capacity (Nominal Bolt Size)		Max. Torque		Free Speed (about)	Overall Length (about)		Weight less Socket or Bit (about)		From Center to Outside (about)		Angle Height (about)		Sq. Drive Shank	
	mm	in	Nm	ft-lbs		rpm	mm	in	kg	lb	mm	in	mm	in	mm
UAN-F087-015	5-8	No.10-5/16	15	11.1	1215	399	15 45/64	1.43	3.15	14.0	35/64	49.0	1 59/64	9.5	3/8
UAN-F130-025	8	5/16	25	18.5	1060	419	16 1/2	1.53	3.37	14.0	35/64	49.0	1 59/64	9.5	3/8
UAN-F130-040	8-10	5/16-3/8	40	29.6	640	444	17 33/64	1.76	3.87	18.0	45/64	52.5	2 2/32	9.5	3/8
UAN-F130-060	10-12	3/8-1/2	60	44.4	440	444	17 33/64	1.77	3.89	18.0	45/64	58.0	2 9/32	12.7	1/2
UAN-F130-080	10-14	3/8-9/16	80	59.0	325	488	19 7/32	3.13	6.87	22.5	7/8	74.0	2 29/32	12.7	1/2
UAN-F130-120	12-16	1/2-5/8	120	88.5	195	488	19 7/32	3.13	6.87	22.5	7/8	74.0	2 29/32	12.7	1/2

The angle height and center to outside info shows the dimensions of head portion.

OPTION

Tool Cable



Model	Part No.
Tool cable 5m	910-911-0
Tool cable 10m	910-912-0
Tool cable 15m	910-913-0
Tool cable 30m	910-914-0

Tool cable is necessary for the connection between tool and controller. It is not included in the tool, so please purchase it separately.

Reaction Bar Assembly



Part No.	Used for
859-553-1	UAN-F130-040, 060
859-554-1	UAN-F130-080, 120

UAT SERIES [SHUT OFF TYPE]

UAT series with high fastening accuracy are at the top in Pneumatic Tools. Oil-Pulse Wrench with 3 advantages ; High Efficiency, High Accuracy and High Durability.

FEATURES

Reliable Torque Accuracy and Assured Shut-Off

- 1 Check Valve (PAT.) senses with accuracy the small volume of high-pressure oil from the Relief Valve section during operation and shuts the tool off as soon as it has reached the target torque. Torque accuracy improved significantly.
- 2 Reset Spring (PAT.) enables to shut off the tool accurately even when the air pressure is lowered to 0.35MPa. (Low Air Pressure Type)

Improvement in Energy Efficiency and Maintenance Cost Reduction

3 Cross Section of Roller Blade

As a measure of pulsing, Roller Blades (*2) (Driving Blade with Roller Pin) are adopted. They greatly reduce the friction inside the pulse unit during operation and power weight ratio has been improved by 50% or more (*3). Compared with our conventional oil-pulse tools, Roller Blades create less frictional wear of Driving Blade, which will reduce maintenance costs.

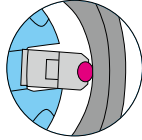

(*2) Roller Blades are adopted to UAT, ULT and UXR series.
(*3) Average value compared with our conventional oil-pulse tools.

4 Cross Section of Sealing

As a measure of sealing, a partition on the anvil and SU-Ring are adopted. The most significant problem of pulse unit is oil sealing because pulsing is repeated dozens of times per second with high pressure. Our study which is gathered over the years helped us to develop URYU's original unique sealing SU-Ring (PAT.). As a result, it extends the maintenance interval by 60% or more (*1).

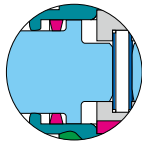

(*1) Compared with our recommended maintenance interval for the conventional oil-pulse tools.

Significant Load Reduction for Operators

- 5 Soft-touch trigger mechanism (PAT.) which can reduce the load for trigger (valve lever) and the compact handgrip greatly reduce the burden for operator's arms, hands and fingers during repeated fastening.

In Consideration of Environment Aspect

- 6 Taking the environment into consideration, the tool's body is unpainted. Body Jacket (*) and Handle Cover are supplied as standard equipment to protect the work.

*Body Jacket is made of oil-proof rubber.

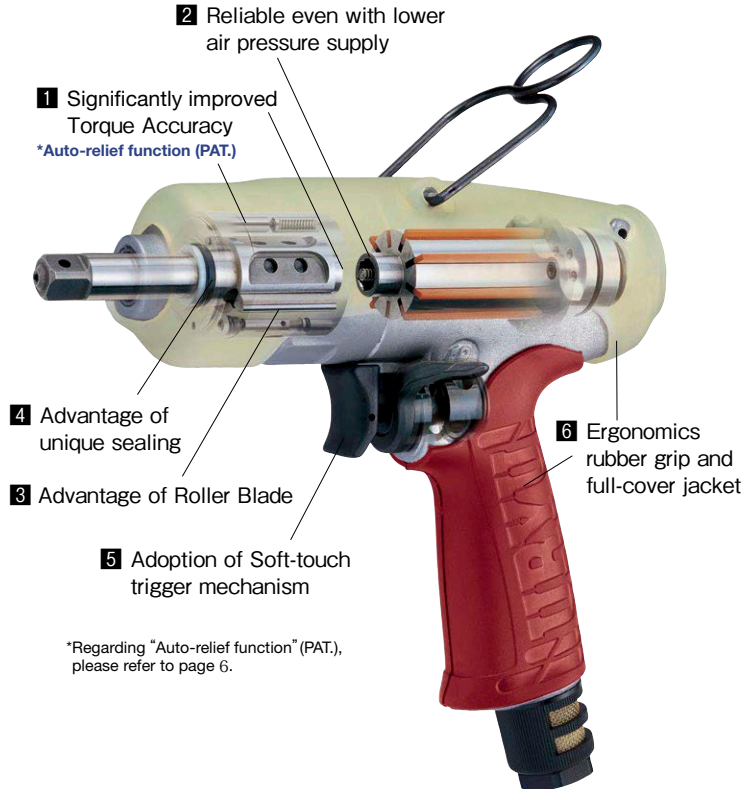

*Regarding "Auto-relief function" (PAT.), please refer to page 6.

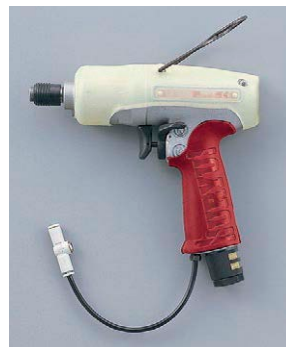

TM type (Fastening Check)
With UTM-1500 Fastening Counter with Poka-Yoke (sold separately), fastening number and time control can be monitored.

UAT SERIES [SHUT OFF TYPE]

UAT series with high fastening accuracy are at the top in Pneumatic Tools.

Oil-Pulse Wrench with 3 advantages ; High Efficiency, High Accuracy and High Durability.

BOLT & NUT SETTERS

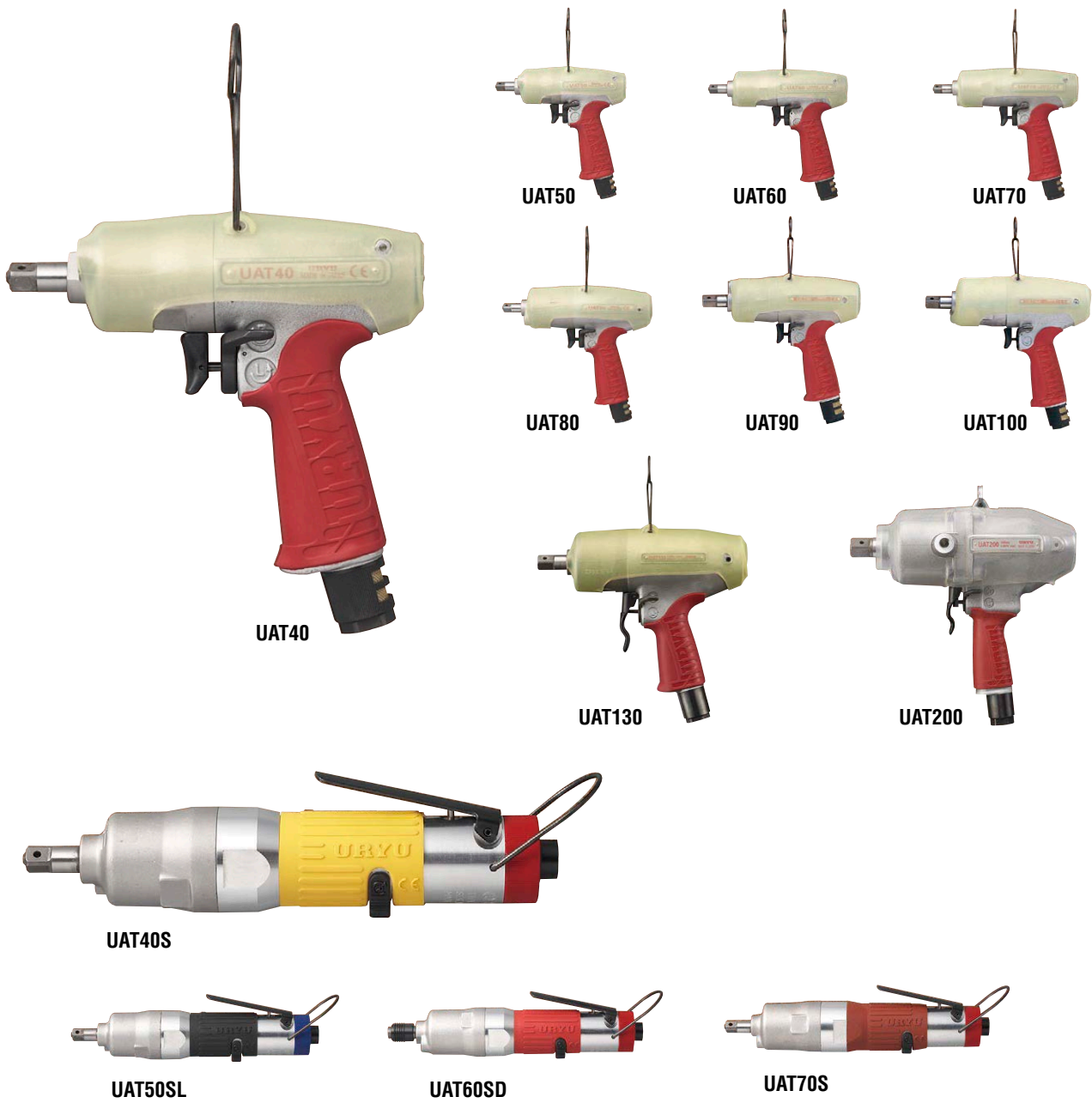

2 types are available for different air pressure level. They can be distinguished by colors.

Standard Type (0.5-0.6MPa)

Low Air Pressure Type (0.4-0.5MPa)



Pistol Type Straight Type Pistol Type Straight Type

*Recommended Air Pressure for UAT30 and UAT40 series is 0.4-0.5MPa.

Quick-change driver anvil type

On pulling the sleeve, insert or take off the bit.

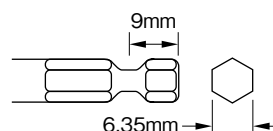

The model name suffixing (D) is the Quick-change driver anvil type.

SPECIFICATIONS

Recommended Air Pressure : 0.4MPa (57psi) ~ 0.6MPa (85psi)

Model	Capacity (Nominal Bolt Size)		Torque Range				Free Speed (Approx.) rpm			Overall Length less Socket or Bit (about)		Weight less Socket or Bit (about)		From Center to Outside (about)		Sq. Drive or Hex. Size		Average Air Consumption	
			0.4~0.5MPa		0.5~0.6MPa		0.4MPa	0.5MPa	0.6MPa	mm	in	kg	lb	mm	in	mm	in	m ³ /min	ft ³ /min
	mm	in	Nm	ft-lbs	Nm	ft-lbs													
UAT30D	4-5	No.8-No.10	2.5-5.5	1.85-4.07	2.5-5.5	1.85-4.07	3600	3800	4200	165	6 1/2	0.88	1.94	23.5	15/16	6.35	1/4	0.30	10.5
UAT40	5	No.10	4.5-8.0	3.3-5.9	4.5-8.0	3.3-5.9	3300	3600	3800	162	6 3/8	0.92	2.0	24.5	31/32	9.5	3/8	0.25	8.8
UAT40D	5	No.10	4.5-8.0	3.3-5.9	4.5-8.0	3.3-5.9	3300	3600	3800	165	6 1/2	0.92	2.0	24.5	31/32	6.35	1/4	0.25	8.8
UAT50	6-8	1/4-5/16	-	-	7.0-15.5	5.2-11.5	-	4400	4600	162	6 3/8	0.92	2.0	24.5	31/32	9.5	3/8	0.25	8.8
UAT50D	6-8	1/4-5/16	-	-	7.0-15.5	5.2-11.5	-	4400	4600	165	6 1/2	0.92	2.0	24.5	31/32	6.35	1/4	0.25	8.8
UAT60	8	5/16	-	-	15.0-32.0	11.1-23.7	-	6300	6700	174	6 27/32	0.95	2.1	24.5	31/32	9.5	3/8	0.35	12.3
UAT60D	8	5/16	-	-	15.0-32.0	11.1-23.7	-	6300	6700	177	6 31/32	0.95	2.1	24.5	31/32	6.35	1/4	0.35	12.3
UAT70	8-10	5/16-3/8	-	-	30.0-55.0	22.2-40.7	-	5700	6000	180	7 3/32	1.05	2.3	25.5	1	9.5	3/8	0.40	14.0
UAT80	10-12	3/8-1/2	-	-	45.0-63.0	33.3-46.6	-	5300	5600	186	7 5/16	1.25	2.8	28.0	1 3/32	9.5	3/8	0.48	16.8
UAT90	10-12	3/8-1/2	-	-	50.0-85.0	37.0-62.9	-	5400	5700	192	7 9/16	1.45	3.2	29.0	1 5/32	12.7	1/2	0.53	18.6
UAT100	12-14	1/2	-	-	70.0-130.0	51.8-96.2	-	4900	5200	199	7 27/32	1.70	3.7	31.5	1 1/4	12.7	1/2	0.55	19.3
UAT130	14	9/16	-	-	110-150	81.4-111	-	4300	4500	217	8 35/64	2.30	5.06	34.0	1 11/32	12.7	1/2	0.70	24.6
UAT150	16	5/8	-	-	140-210	103.6-155.4	-	3800	3900	240	9 29/64	2.90	6.4	38.0	1 1/2	19.0	3/4	0.70	24.6
UAT180	16-18	5/8-3/4	-	-	160-250	118.4-185.0	-	3100	3300	264	10 25/64	3.7	8.1	52.0	2 3/64	19.0	3/4	0.70	24.6
UAT200	18-20	3/4	-	-	200-400	148-296	-	2300	2400	279	10 63/64	5.80	12.76	49.5	1 31/32	19.0	3/4	1.00	35.2
UAT50L	6-8	1/4-5/16	7.0-15.5	5.2-11.5	-	-	4000	4300	-	162	6 3/8	0.92	2.0	24.5	31/32	9.5	3/8	0.25	8.8
UAT50DL	6-8	1/4-5/16	7.0-15.5	5.2-11.5	-	-	4000	4300	-	165	6 1/2	0.92	2.0	24.5	31/32	6.35	1/4	0.25	8.8
UAT60L	8	5/16	13.0-28.0	9.6-20.7	-	-	6000	6500	-	174	6 27/32	0.95	2.1	24.5	31/32	9.5	3/8	0.25	8.8
UAT60DL	8	5/16	13.0-28.0	9.6-20.7	-	-	6000	6500	-	177	6 31/32	0.95	2.1	24.5	31/32	6.35	1/4	0.25	8.8
UAT70L	8-10	5/16-3/8	25.0-48.0	18.5-35.5	-	-	5300	5600	-	180	7 3/32	1.05	2.3	25.5	1	9.5	3/8	0.30	10.5
UAT80L	10-12	3/8-1/2	35.0-55.0	25.9-40.7	-	-	5000	5300	-	186	7 5/16	1.25	2.8	28.0	1 3/32	9.5	3/8	0.40	14.0
UAT90L	10-12	3/8-1/2	45.0-75.0	33.3-55.5	-	-	5100	5600	-	192	7 9/16	1.45	3.2	29.0	1 5/32	12.7	1/2	0.45	15.8
UAT100L	12	1/2	60.0-110.0	44.4-81.4	-	-	4800	5200	-	199	7 27/32	1.70	3.7	31.5	1 1/4	12.7	1/2	0.48	16.8
UAT130L	12-14	1/2-9/16	80.0-125.0	59.2-92.5	-	-	4100	4400	-	217	8 35/64	2.30	5.06	34.0	1 11/32	12.7	1/2	0.50	17.6
UAT150L	14-16	9/16-5/8	110.0-170.0	81.4-125.8	-	-	3700	3800	-	240	9 29/64	2.9	6.4	38.0	1 1/2	19.0	3/4	0.50	17.6
UAT180L	16	5/8	130.0-210.0	96.2-155.4	-	-	3000	3100	-	264	10 25/64	3.7	8.1	52.0	2 3/64	19.0	3/4	0.50	17.6
UAT200L	16-18	5/8-3/4	170.0-280.0	125.8-207.2	-	-	2200	2300	-	279	10 63/64	5.80	12.76	49.5	1 31/32	19.0	3/4	0.70	24.6

Air Inlet Thread : NPT 1/4" for UAT30D-UAT150(L)
NPT 3/8" for UAT180(L)

Air Hose Size (Inside Diameter) : 6.5mm(1/4") for UAT30D - UAT50
11.0mm(7/16") for UAT100L - UAT180(L)

8.0mm(5/16") for UAT60 - UAT100
12.7mm(1/2") for UAT200(L)

SPECIFICATIONS

Recommended Air Pressure : 0.4MPa (57psi) ~ 0.6MPa (85psi)

Model	Capacity (Nominal Bolt Size)		Torque Range				Free Speed (Approx.) rpm			Overall Length less Socket or Bit (about)		Weight less Socket or Bit (about)		From Center to Outside (about)		Sq. Drive or Hex. Size		Average Air Consumption	
			0.4~0.5MPa		0.5~0.6MPa		0.4MPa	0.5MPa	0.6MPa	mm	in	kg	lb	mm	in	mm	in	m ³ /min	ft ³ /min
	mm	in	Nm	ft-lbs	Nm	ft-lbs													
UAT30SD	4-5	No.8-No.10	2.5-5.5	1.85-4.07	2.5-5.5	1.85-4.07	3100	3300	3400	222	8 47/64	0.75	1.94	21.5	27/32	6.35	1/4	0.35	12.3
UAT40S	5	No.10	4.5-8.0	3.3-5.9	4.5-8.0	3.3-5.9	3000	3200	3300	224	8 13/16	0.85	1.9	22.5	7/8	9.5	3/8	0.20	7.0
UAT40SD	5	No.10	4.5-8.0	3.3-5.9	4.5-8.0	3.3-5.9	3000	3200	3300	227	8 15/16	0.85	1.9	22.5	7/8	6.35	1/4	0.20	7.0
UAT50S	6-8	1/4-5/16	-	-	7.0-15.5	5.2-11.5	-	3700	3900	224	8 13/16	0.85	1.9	22.5	7/8	9.5	3/8	0.25	8.8
UAT50SD	6-8	1/4-5/16	-	-	7.0-15.5	5.2-11.5	-	3700	3900	227	8 15/16	0.85	1.9	22.5	7/8	6.35	1/4	0.25	8.8
UAT60S	8	5/16	-	-	15.0-32.0	11.1-23.7	-	5400	5700	229	9	0.87	1.9	22.5	7/8	9.5	3/8	0.30	10.5
UAT60SD	8	5/16	-	-	15.0-32.0	11.1-23.7	-	5400	5700	232	9 1/8	0.87	1.9	22.5	7/8	6.35	1/4	0.30	10.5
UAT70S	8-10	5/16-3/8	-	-	30.0-50.0	22.2-37.0	-	4400	4700	239	9 13/32	0.95	2.1	23.5	7/8	9.5	3/8	0.35	12.3
UAT50SL	6-8	1/4-5/16	7.0-15.5	5.2-11.5	-	-	3800	4000	-	224	8 13/16	0.85	1.9	22.5	7/8	9.5	3/8	0.20	7.0
UAT50SDL	6-8	1/4-5/16	7.0-15.5	5.2-11.5	-	-	3800	4000	-	227	8 15/16	0.85	1.9	22.5	7/8	6.35	1/4	0.20	7.0
UAT60SL	8	5/16	13.0-28.0	9.6-20.7	-	-	5300	5600	-	229	9	0.87	1.9	22.5	7/8	9.5	3/8	0.25	8.8
UAT60SDL	8	5/16	13.0-28.0	9.6-20.7	-	-	5300	5600	-	232	9 1/8	0.87	1.9	22.5	7/8	6.35	1/4	0.25	8.8
UAT70SL	8-10	5/16-3/8	25.0-45.0	18.5-33.3	-	-	4400	4700	-	239	9 13/32	0.95	2.1	23.5	7/8	9.5	3/8	0.27	9.5

Air Inlet Thread : NPT 1/4"

Air Hose Size (Inside Diameter) : 6.5mm(1/4") for UAT30SD - UAT50S 8.0mm(5/16") for UAT60S - UAT70S

UXR-T SERIES

SPECIFICATIONS

Recommended Air Pressure:0.6MPa(85psi)

Model	Capacity (Nominal Bolt Size)		Torque Range		Free Speed (about) rpm		Overall Length less Socket or Bit (about)		Weight less Socket or Bit (about)		From Center to Outside (about)		Sq. Drive or Hex. Size		Average Air Consumption	
	mm	in	Nm	ft-lbs	0.5MPa	0.6MPa	mm	in	kg	lb	mm	in	mm	in	m ³ /min	ft ³ /min
UXR-T2400S	24	7/8	360-650	260-470	3400	3600	444	17 31/64	12.00	26.46	61.5	2 27/64	25.4	1	1.00	35.3
UXR-T3000S	30	1 1/8	450-850	330-620	4200	4400	477	18 25/32	14.50	31.97	62.0	2 7/16	25.4	1	1.05	37.1

Air Inlet Thread : NPT1/2"

Air Hose Size : 12.7mm (1/2")

Inside Trigger is available

UL SERIES [NON SHUT-OFF TYPE]

Ultralight Oil-Pulse Tool. Reduce the burden on the operators.

BOLT & NUT SETTERS



Quick-change driver anvil type

On pulling the sleeve, insert or take off the bit.



The model name suffixing (D) is the Quick-change driver anvil type.

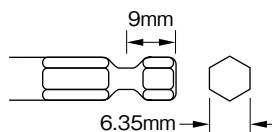

SPECIFICATIONS

Recommended Air Pressure : 0.5MPa (72psi) - 0.6MPa (85psi)

Model	Capacity (Nominal Bolt Size)		Torque Range				Free Speed (Approx.) rpm		Overall Length Less Socket or Bit (Approx.)		Weight less Socket or Bit (Approx.)		From Center to Outside (Approx.)		Sq. Drive or Hex. Size		Average Air Consumption	
			0.5MPa		0.6MPa		0.5MPa	0.6MPa	mm	in	kg	lb	mm	in	mm	in	m ³ /min	ft ³ /min
	mm	in	Nm	ft-lbs	Nm	ft-lbs	0.5MPa	0.6MPa	mm	in	kg	lb	mm	in	mm	in	m ³ /min	ft ³ /min
UL30	5	No.10	5.5-10.5	4.1-7.8	6-12	4.4-8.9	5400	5700	133	5 15/64	0.70	1.5	20.5	13/16	9.5	3/8	0.20	7.0
UL30D	5	No.10	5.5-10.5	4.1-7.8	6-12	4.4-8.9	5400	5700	137	5 25/64	0.70	1.5	20.5	13/16	6.35	1/4	0.20	7.0
UL40	5-6	No.10-1/4	11-20	8.1-14.8	13-22	9.6-16.3	5800	6100	133	5 15/64	0.70	1.5	20.5	13/16	9.5	3/8	0.20	7.0
UL40D	5-6	No.10-1/4	9-17	6.7-12.6	11-20	8.1-14.8	5800	6100	137	5 25/64	0.70	1.5	20.5	13/16	6.35	1/4	0.20	7.0
UL50	6-8	1/4-5/16	20-32	14.8-23.7	22-35	16.3-25.9	6100	6400	140	5 33/64	0.77	1.7	22.0	55/64	9.5	3/8	0.30	10.5
UL50D	6-8	1/4-5/16	16-25	11.8-18.5	18-28	13.3-20.7	6100	6400	146	5 3/4	0.77	1.7	22.0	55/64	6.35	1/4	0.30	10.5
UL60	8	5/16	30-45	22.2-33.3	32-50	23.7-37.0	6700	7000	140	5 33/64	0.82	1.8	22.0	55/64	9.5	3/8	0.40	14.0
UL60D	8	5/16	20-32	14.8-23.7	22-35	16.3-25.9	6700	7000	143	5 5/8	0.82	1.8	22.0	55/64	6.35	1/4	0.40	14.0
UL70	8-10	5/16-3/8	36-60	26.6-44.4	40-65	29.6-48.1	5400	5700	153	6 1/32	0.95	2.1	23.0	29/32	9.5	3/8	0.45	15.8
* UL80	10-12	3/8-1/2	40-55	29.6-40.7	45-70	33.3-50.0	5600	5900	162	6 3/8	1.15	2.5	26.0	1 1/32	9.5	3/8	0.48	16.8
UL90	10-12	3/8-1/2	55-90	40.7-66.6	60-100	44.4-74.0	5700	6000	170	6 11/16	1.30	2.9	27.0	1 1/16	12.7	1/2	0.53	18.6
UL100	12-14	1/2	72-120	53.3-88.8	80-130	59.2-96.2	5100	5400	177	6 31/32	1.66	3.7	29.5	1 5/32	12.7	1/2	0.58	20.3
UL130	14	9/16	90-145	66.6-107.3	100-160	74.0-118.4	4200	4400	197	7 3/4	2.30	5.1	32.0	1 17/64	12.7	1/2	0.65	22.7
UL150	16	5/8	135-210	99.6-154.7	150-230	109.9-169.6	3500	3800	213	8 25/64	3.00	6.6	36.0	1 27/64	19.0	3/4	0.70	24.7
UL30S	5	No.10	5.5-10.5	4.1-7.8	6-12	4.4-8.9	4700	5000	205	8 5/64	0.62	1.4	20.5	51/64	9.5	3/8	0.23	8.1
UL30SD	5	No.10	5.5-10.5	4.1-7.8	6-12	4.4-8.9	4700	5000	209	8 15/64	0.62	1.4	20.5	51/64	6.35	1/4	0.23	8.1
UL40S	5-6	No.10-1/4	11-20	8.1-14.8	11-22	8.1-16.3	4700	5000	205	8 5/64	0.62	1.4	20.5	51/64	9.5	3/8	0.23	8.1
UL40SD	5-6	No.10-1/4	9-17	6.7-12.6	9-20	6.7-14.8	4700	5000	209	8 15/64	0.62	1.4	20.5	51/64	6.35	1/4	0.23	8.1
UL50S	6-8	1/4-5/16	20-32	14.8-23.7	22-35	16.3-25.9	6100	6400	208	8 3/16	0.74	1.6	22.0	7/8	9.5	3/8	0.35	12.3
UL50SD	6-8	1/4-5/16	16-25	11.8-18.5	18-28	13.3-20.7	6100	6400	214	8 27/64	0.74	1.6	22.0	7/8	6.35	1/4	0.35	12.3
UL60S	8	5/16	30-45	22.2-33.3	32-50	23.7-37.0	6400	6700	209	8 15/64	0.77	1.7	22.0	7/8	9.5	3/8	0.45	15.8
UL60SD	8	5/16	20-32	14.8-23.7	22-35	16.3-25.9	6400	6700	212	8 11/32	0.77	1.7	22.0	7/8	6.35	1/4	0.45	15.8
UL70S	8-10	5/16-3/8	36-60	26.6-44.4	36-60	26.6-44.4	5100	5400	223	8 25/32	0.87	1.9	23.5	59/64	9.5	3/8	0.40	14

Air Inlet Size : NPT1/4"

Air Hose Size : 10mm×6.5mm×5m for UL30-50 12mm×8.0mm×5m for UL60-150

Air Hose Size : 10mm×6.5mm×5m for UL30S-50S 12mm×8.0mm×5m for UL60S-70S

*Please refrain from using UL80 at around max. torque as it is developed to aim at torque output between UL70 & UL90.

CORNER TYPE ULT / UX SERIES

ULT SERIES [SHUT OFF TYPE]

Easy to operate in narrow area.
Reliable fastening with oil-pulse wrench.

2 types are available for different air pressure level.
They can be distinguished by colors.



Standard Type
(0.5~0.6MPa)

Low Air Pressure Type
(0.4~0.5MPa)

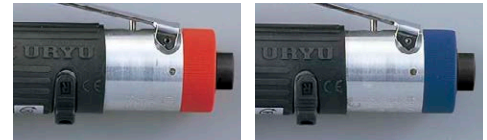

★To do torque adjustment...

Remove the Hammer Casing Nut and confirm you see the Relief Valve Spindle through the hole. Use Allen Wrench (1.5mm) to adjust torque. Turn the Relief Valve Spindle clockwise to increase tightening torque and anti-clockwise to decrease tightening torque. Fix the Hammer Casing Nut firmly after adjustment.

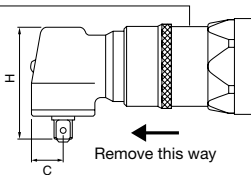

Head Sizes

Model	H		C		Model	H		C	
	mm	in	mm	in		mm	in	mm	in
ULT40C	59	2 21/64	16	5/8	ULT70C	70	2 3/4	18	45/64
ULT50C	59	2 21/64	16	5/8	ULT70CH	77	3 1/32	22	7/8
ULT60C	59	2 21/64	16	5/8					

SPECIFICATIONS

Recommended Air Pressure : 0.4MPa (57psi) - 0.6MPa (85psi)

Model	Capacity (Nominal Bolt Size)		Torque Range				Free Speed (Approx.) rpm		Overall Length less Socket or Bit (about)		Weight less Socket or Bit (about)		From Center to Outside (about)		Sq. Drive or Hex. Size		Average Air Consumption	
			0.4~0.5MPa		0.5~0.6MPa		0.4MPa	0.6MPa	mm	in	kg	lb	mm	in	mm	in	m ³ /min	ft ³ /min
	mm	in	Nm	ft-lbs	Nm	ft-lbs												
ULT40C	5	No.10	-	-	4.5-7.5	3.33-5.55	3300	3500	250	9 27/32	1.30	2.9	24.5	31/32	9.5	3/8	0.20	7.0
ULT50C	6-8	1/4-5/16	-	-	7.0-15.5	5.2-11.5	-	4500	250	9 27/32	1.35	3.0	24.5	31/32	9.5	3/8	0.25	8.6
ULT60C	8	5/16	-	-	13-28	9.6-20.7	-	5200	261	10 9/32	1.45	3.2	24.5	31/32	9.5	3/8	0.30	10.5
ULT70C	8	5/16	-	-	20-35	14.8-25.9	-	4400	275	10 53/64	1.65	3.6	26.5	1 3/64	9.5	3/8	0.35	12.3
ULT70CH	8-10	5/16-3/8	-	-	30-50	22.2-37.0	-	2500	290	11 27/64	1.85	4.1	26.5	1 3/64	12.7	1/2	0.35	12.3
ULT50CL	6-8	1/4-5/16	7.0-15.5	5.2-11.5	-	-	4500	-	250	9 27/32	1.35	3.0	24.5	31/32	9.5	3/8	0.20	7.0
ULT60CL	8	5/16	13-28	9.6-20.7	-	-	5200	-	261	10 9/32	1.45	3.2	24.5	31/32	9.5	3/8	0.25	8.6
ULT70CL	8	5/16	20-35	14.8-25.9	-	-	4300	-	275	10 53/64	1.65	3.6	26.5	1 3/64	9.5	3/8	0.27	9.5
ULT70CHL	8-10	5/16-3/8	30-50	22.2-37.0	-	-	2300	-	290	11 27/64	1.85	4.1	26.5	1 3/64	12.7	1/2	0.27	9.5

Air Inlet Size : NPT 1/4"

Air Hose Size : 10mmx6.5mmx5m for ULT40C~50C(L) 12mmx8.0mmx5m for ULT60C~70C(L) , and 70CH(L)

UX SERIES [NON SHUT-OFF TYPE]



Head Sizes

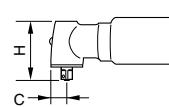

Model	C		H	
	mm	in	mm	in
UX-500C	15.0	19/32	59.5	2 11/32
UX-612C	16.0	5/8	59.5	2 11/32
UX-700C	16.0	5/8	62.0	2 7/16
UX-800C	18.0	45/64	70.0	2 3/4
UX-900C	18.0	45/64	70.0	2 3/4
UX-1000C	21.5	27/32	80.0	3 5/32

SPECIFICATIONS

Recommended Air Pressure : 0.6MPa (85psi)

Model	Capacity (Nominal Bolt Size)		Torque Range				Free Speed (Approx.) rpm		Overall Length (about)		Weight less Socket or Bit (about)		Angle Height (about)		Sq. Drive or Hex. Size		Average Air Consumption	
			0.5MPa		0.6MPa		0.5MPa	0.6MPa	mm	in	kg	lb	mm	in	mm	in	m ³ /min	ft ³ /min
	mm	in	Nm	ft-lbs	Nm	ft-lbs												
UX-500C	5-6	No. 10-1/4	11-17	8.0-12.5	13-20	10.0-15.0	8800	9300	270	10 5/8	1.28	2.8	59.5	2 11/32	9.5	3/8	0.25	8.8
UX-612C	6	1/4	13.5-24	9.9-17.7	16-28	12.0-20.0	9300	9800	283	11 9/64	1.38	3.0	59.5	2 11/32	9.5	3/8	0.32	11.2
UX-700C	8	5/16	17-31	12.5-22.8	20-36	16.0-28.0	9000	9500	273	10 3/4	1.67	3.7	62.0	2 7/16	9.5	3/8	0.35	12.3
UX-800C	8-10	5/16-3/8	25-36	18.4-26.5	29-43	20.0-31.0	8500	9000	285	11 7/32	1.93	4.3	70.0	2 3/4	9.5	3/8	0.40	14.1
UX-900C	10	3/8	30-47	22.1-34.6	35-55	25.0-40.0	7300	7600	338	13 5/16	2.25	5.0	70.0	2 3/4	9.5	3/8	0.42	14.9
UX-1000C	10-12	3/8-1/2	43-68	31.7-50.1	50-80	40.0-58.0	6600	6800	365	14 3/8	3.05	6.8	80.0	2 5/32	12.7	1/2	0.51	17.9
UX-612A	6	1/4	13.5-24	9.9-17.7	16-28	12.0-20.0	9300	9800	297	11 11/16	1.38	3.0	-	-	9.5	3/8	0.30	10.5

Air Inlet size : NPT1/4"

Air Hose Size : 6.35mm (1/4") for UX-500C 9.5mm (3/8") for UX-612C-UX-1000C

U / UX / UXR / UX-ST SERIES [NON SHUT-OFF TYPE]

U-Wrench was released in 1978, UX-Wrench was released in 1984. Our long-selling tools proud reliability and achievements.



UXR-1820



UX-900S



U-310SD

Quick-change driver anvil type

On pulling the sleeve, insert or take off the bit.

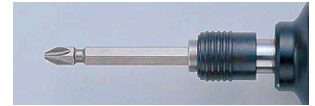
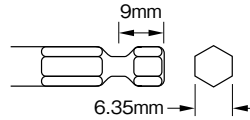

The model name suffixing (D) is the Quick-change driver anvil type.

SPECIFICATIONS

Recommended Air Pressure : 0.6MPa (85psi)

Model	Capacity (Nominal Bolt Size)		Torque Range				Free Speed (Approx.) rpm		Overall Length (about)		Weight less Socket or Bit (about)		From Center to Outside (about)		Sq. Drive or Hex. Size		Average Air Consumption	
			0.5MPa		0.6MPa		0.5MPa	0.6MPa										
	mm	in	Nm	ft-lbs	Nm	ft-lbs	0.5MPa	0.6MPa	mm	in	kg	lb	mm	in	mm	in	m ³ /min	ft ³ /min
U-310SD	3-4	No.5-No.8	2.1-2.6	1.6-1.9	2.5-3.1	1.8-2.2	10000	11000	222	8 47/64	0.62	1.5	18.0	47/64	6.35	1/4	0.15	5.3
U-350SD	3-4	No.5-No.8	3.0-5.0	2.2-3.7	3.5-5.8	2.5-4.2	10000	10500	238	9 3/8	0.71	1.5	22.0	47/64	6.35	1/4	0.15	5.3
U-350D	3-4	No.5-No.8	3.0-5.0	2.2-3.7	3.5-5.8	2.5-4.2	10000	10500	154	6 1/16	0.77	1.7	22.0	7/8	6.35	1/4	0.15	5.3
UXR-1820	16-18	5/8-3/4	135-215	99.6-158.7	160-250	120-185	4400	4600	242	9 17/32	4.10	9.0	42.0	1 21/32	19.0	3/4	0.75	26.3
UXR-2000	18-20	3/4	255-385	188.2-284.1	300-450	220-330	4000	4200	282	11 7/64	6.50	14.3	47.0	1 27/32	19.0	3/4	0.90	31.5

Air Inlet Thread : NPT1/4" for U-350D
NPT3/8" for UXR-1820 & UXR-2000

Air Hose Size : 6.35mm (1/4") for U-350D
12.7mm (1/2") for UXR-1820 & UXR-2000

SPECIFICATIONS

Recommended Air Pressure : 0.6MPa (85psi)

Model	Capacity (Nominal Bolt Size)		Torque Range				Free Speed (Approx.) rpm		Overall Length (about)		Weight less Socket or Bit (about)		From Center to Outside (about)		Sq. Drive or Hex. Size		Average Air Consumption	
			0.5MPa		0.6MPa		0.5MPa	0.6MPa										
	mm	in	Nm	ft-lbs	Nm	ft-lbs	0.5MPa	0.6MPa	mm	in	kg	lb	mm	in	mm	in	m ³ /min	ft ³ /min
UX-900S	10	3/8	38-64	28-47.2	45-75	35-55	7300	7600	310	12 13/64	1.80	3.9	37.5	1 9/64	12.7	1/2	0.42	14.9
UX-1000S	10-12	3/8-1/2	43-81	31.7-59.8	50-95	40-70	6500	6800	320	12 19/32	2.10	4.6	39.0	1 17/64	12.7	1/2	0.51	17.9
UX-1300S	13-14	1/2-9/16	68-110	50.2-81.2	80-130	60-95	5800	6200	336	13 15/64	2.55	6.6	42.0	1 11/32	12.7	1/2	0.55	19.4
UXR-2000S	18-20	3/4	255-385	188-284	300-450	220-330	4000	4200	340	13 25/64	7.00	15.4	47.0	1 27/32	19.0	3/4	0.90	31.6
UXR-2400S	24	7/8	340-550	251-406	400-650	290-470	3700	4000	385	15 5/32	11.00	23.7	55.0	2 1/8	25.4	1	1.00	35.2
UXR-3000S	30	1/4	425-725	313-535	500-850	360-630	4200	4400	455	17 29/32	13.30	29.3	62.0	2 1/8	25.4	1	1.05	37.1

Air Inlet Size : NPT1/4" for UX-900S-UX-1300S NPT3/8" for UXR-2000S
NPT1/2" for UXR-2400S & UXR-3000S

Inside Trigger is available for UXR-2000S-UXR-3000S
Air Hose Size : 9.5mm (3/8") for UX-900S-UX-1300S
12.7mm (1/2") for UXR-2000S-UXR-3000S

STUD BOLT WRENCHES

FEATURES

Auto-reversing mechanism

These unique Push-Pull type Oil-Pulse tools simplify stud-bolt driving job considerably without any special operation for frequent reversing. Push the tool forward to the application for driving and simply pull back for automatic reversing.

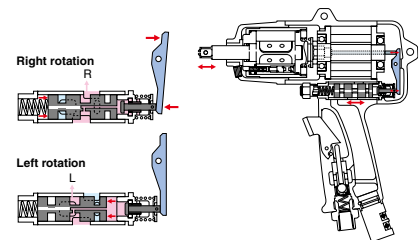

UX-ST1000



UX-ST800

SPECIFICATIONS

Recommended Air Pressure : 0.6MPa (85psi)

Model	Capacity (Nominal Bolt Size)		Torque Range				Free Speed (Approx.) rpm		Overall Length (about)		Weight less Socket or Bit (about)		From Center to Outside (about)		Sq. Drive or Hex. Size		Average Air Consumption	
			0.5MPa		0.6MPa		0.5MPa	0.6MPa										
	mm	in	Nm	ft-lbs	Nm	ft-lbs	0.5MPa	0.6MPa	mm	in	kg	lb	mm	in	mm	in	m ³ /min	ft ³ /min
UX-ST800	8-10	5/16-3/8	30-47	22-35	35-55	25-40	7000	7300	195	7 43/64	1.75	3.8	28.0	1 3/32	9.5	3/8	0.30	10.5
UX-ST1000	10-12	3/8-1/2	43-77	32-57	50-90	40-65	6000	6300	210	8 17/64	2.50	5.5	33.0	1 19/64	12.7	1/2	0.48	16.8

Air Inlet Size: NPT1/4"
Air Hose Size: 9.5mm (3/8")

CUSTOM-MADE MODELS

*These Models are specially designed for user's request.



RATCHET WRENCHES



URW-8



URW-6



URW-12N



URW-8N



URW-12NB



URW-10N

FEATURES

Most suitable for fastening in narrow application. Bent head type, Thinner head type and Extended head type are also available for hard-to-reach access fastening jobs.

Reverse rotation is obtained by simply turning a tool over.

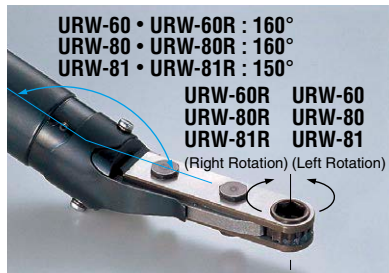

Head Sizes

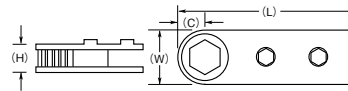

Model	H		W		L		C	
	mm	in	mm	in	mm	in	mm	in
URW-6,60,60R	13.0	33/64	20.0	25/32	88.0	3 15/32	10.0	25/64
URW-8,8N,9N,80,80R,81,81R	18.0	45/64	25.0	63/64	102.5	4 1/32	12.5	31/64
URW-10N	18.0	45/64	33.0	1 19/64	106.5	4 3/16	16.5	21/32
URW-12N	18.0	45/64	36.0	1 27/64	109.5	4 5/16	18.0	45/64
URW-12NA	18.0	45/64	46.0	1 13/16	120.5	4 3/4	23.0	29/32
URW-12NB	18.0	45/64	54.0	2 1/8	128.5	5 1/16	27.0	1 1/16

SPECIFICATIONS

Recommended Air Pressure : 0.4MPa (57psi)

Model	Capacity (Nominal Bolt Size)		Max. Torque		Free Speed (about)	Overall Length (about)		Weight (about)		Hex Size of Ratchet Wrench		Average Air Consumption	
	mm	in	Nm	ft-lbs		mm	in	kg	lb	mm	in	m ³ /min	ft ³ /min
URW-6	6	1/4	11	8.1	210	292	11 1/2	1.15	2.53	6, 7, 8, 10, 11, 12	1/4, 5/16, 3/8, 7/16	0.28	9.9
URW-60, 60R	6	1/4	11	8.1	210	288	11 11/32	1.15	2.53	6, 7, 8, 10, 11, 12	1/4, 5/16, 3/8, 7/16	0.28	9.9
URW-8N	8	5/16	16	11.8	260	300	11 13/16	2.25	4.95	7, 8, 9, 10, 11, 12, 13, 14, 15	7/16, 1/2, 9/16	0.55	19.5
URW-80, 80R	8	5/16	16	11.8	240	300	11 13/16	2.25	4.95	7, 8, 9, 10, 11, 12, 13, 14, 15	7/16, 1/2, 9/16	0.55	19.5
URW-81, 81R	8	5/16	16	11.8	240	300	11 13/16	2.25	4.95	7, 8, 9, 10, 11, 12, 13, 14, 15	7/16, 1/2, 9/16	0.55	19.5
URW-8	8	5/16	16	11.8	240	360	14 3/16	1.90	4.18	7, 8, 9, 10, 11, 12, 13, 14, 15	7/16, 1/2, 9/16	0.56	19.8
URW-9N	10	3/8	31	22.9	140	380	15	2.35	5.17	7, 8, 9, 10, 11, 12, 13, 14, 15	7/16, 1/2, 9/16	0.67	23.7
URW-10N	10	3/8	57	42.2	155	394	15 33/64	2.65	5.83	10, 12, 13, 14, 15, 16, 17, 18, 19	9/16, 5/8, 11/16, 3/4	0.70	25.0
URW-12N	13	1/2	59	43.7	145	397	15 5/8	2.70	5.94	12, 14, 16, 17, 18, 19, 21, 22, 23	3/8, 1/2, 9/16, 5/8, 11/16, 3/4, 13/16	0.70	25.0
URW-12NA	14	9/16	78	57.7	105	408	16 1/16	2.80	6.16	17, 18, 19, 21, 22, 23, 24, 26, 27	11/16, 3/4, 15/16	0.70	25.0
URW-12NB	16	5/8	93	68.8	90	416	16 19/64	2.90	6.38	24, 29, 30, 32	5/8, 11/16, 3/4, 13/16, 7/8, 15/16, 1, 1-1/8	0.70	25.0

Air Inlet Thread (Pipe Tap) : NPT1/4"
 Air Hose Size (Inside Diameter) : 9.5mm (3/8")
 Specify Hex. size when ordering.
 Max Torque is a guideline at 0.6MPa.

OPEN-END WRENCHES / GEARED WRENCHES



UOW-11-14



UOW-11-10



UOW-11-22



UOW-11-30



UOW-T60-22



UGW-8N

Safety Start Lever

Safety Start Lever is installed as standard equipment for UOW series to prevent accidental start of tool.

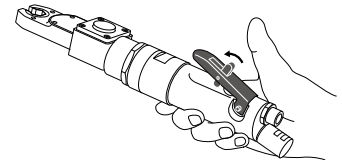

Push down the self-locking lever to operate tool as above.

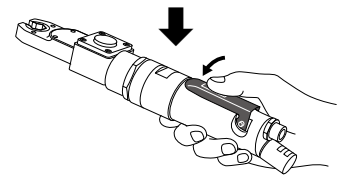

FEATURES

(OPEN-END WRENCHES)

URYU offers two types of Open-End Wrenches for fast, accurate tube nut tightening. **UOW-11 series** is a stall torque type and **UOW-T60 series** is a mechanical shut-off type with external torque adjustment.

(GEARED WRENCHES)

Gear drive mechanism amplifies and transmits the motor rotation power. **UGW** Geared Wrench offers quiet operation with good durability.

EXTERNAL DIAL

Torque adjustment. (No special tool is needed)



1 : Min.
3 : Max.

UOW-T60 series only.

Head Sizes	Model	H		W		O		C	
		mm	in	mm	in	mm	in	mm	in
	UOW-11-10,UOW-T60-10	14.0	35/64	37.0	1 29/64	5.0~6.0	13/64~15/64	10.0	25/64
	UOW-11-14,UOW-T60-14	14.0	35/64	40.0	1 37/64	6.0~9.0	15/64~23/64	13.0	33/64
	UOW-11-22,UOW-T60-22	16.0	5/8	56.0	2 13/64	13.0~15.0	33/64~19/32	17.0	43/64
	UOW-11-30,UOW-T60-30	16.0	5/8	68.0	2 43/64	15.0~23.0	19/32~29/32	21.0	53/64
	UGW-6N	14.0	35/64	32.0	1 17/64	-	-	12.9	33/64
	UGW-8N	14.0	35/64	36.0	1 27/64	-	-	15.8	39/64

SPECIFICATIONS

Recommended Air Pressure : 0.6MPa (85psi)

Model	Max. Torque / Range		Free Speed (about)	Overall Length (about)		Weight (about)		Hex Size of Ratchet Wrench		Average Air Consumption	
	Nm	ft-lbs		rpm	mm	in	kg	lb	mm	in	m ³ /min
UOW-11-10	13	9.6	390	295	11 47/64	1.50	3.31	7, 8, 9, 10, 11, 12		0.30	10.5
UOW-11-14	16	11.8	290	311	12 1/4	1.60	3.52	10, 11, 12, 13, 14, 15, 16, 17		0.30	10.5
UOW-11-22	24	17.8	220	326	12 53/64	1.75	3.85	11, 12, 13, 14, 15, 16, 17, 18, 19, 20, 21, 22, 24		0.30	10.5
UOW-11-30	32	23.7	160	347	13 21/32	2.00	4.40	14, 17, 18, 19, 23, 24, 26, 27, 29, 30, 32		0.30	10.5
UOW-T60-10	4-14	3.0-10.4	300	370	14 5/8	2.10	4.62	7, 8, 9, 10, 11, 12		0.30	10.5
UOW-T60-14	5-17	3.7-12.6	240	385	15 1/8	2.20	4.85	10, 11, 12, 13, 14, 15, 16, 17		0.30	10.5
UOW-T60-22	7-24	5.2-17.8	170	400	15 3/4	2.35	5.18	11, 12, 13, 14, 15, 16, 17, 18, 19, 20, 21, 22, 24		0.30	10.5
UOW-T60-30	10-32	7.4-23.7	130	420	16 5/8	2.60	5.73	14, 17, 18, 19, 23, 24, 26, 27, 29, 30, 32		0.30	10.5
UGW-6N	18	13.3	530	310	12 13/64	1.40	3.08	9, 10, 11, 12		0.30	10.5
UGW-8N	23	17.0	410	322	12 11/16	1.45	3.19	10, 12, 13, 14, 17		0.30	10.5

Air Inlet Thread (Pipe Tap) : NPT1/4" Air Hose Size (Inside Diameter) : 9.5mm (3/8")
Specify Hex. size when ordering.

ANGLE NUTRUNNERS

Instant automatic shut-off providing reduced reaction.
Low inertia design providing increased accuracy.



UAN-611RM TORQUE MONITORING TYPE



UAN-611R-30C

FEATURES

- Simple and accurate method to adjust torque output by Phillips Driver permitting quick setup.
- Designed with a spline type interface allowing multiple head positions for the most comfortable throttle location on those hard to reach applications.
- The pneumatic motor is designed to offer high power performance by reducing motor inertia to the minimum level.
- Ergonomically designed Protector offers firm gripping for ergonomic fastening.

Head Sizes	Model	C		H	
		mm	in	mm	in
	UAN-611R-60C, UAN-611RM-60C	14.0	35/64	47.0	1 27/32
	UAN-611R-50C, UAN-611RM-50C	14.0	35/64	47.0	1 27/32
	UAN-611R-40C, UAN-611RM-40C	14.0	35/64	47.0	1 27/32
	UAN-611R-30C, UAN-611RM-30C	14.0	35/64	47.0	1 27/32
	UAN-701R-60C, UAN-701RM-60C	14.0	35/64	47.0	1 27/32
	UAN-701R-40C, UAN-701RM-40C	18.0	45/64	51.0	2 1/64
	UAN-701R-30C, UAN-701RM-30C	18.0	45/64	58.0	2 9/32

System Layout For Torque Monitoring Type

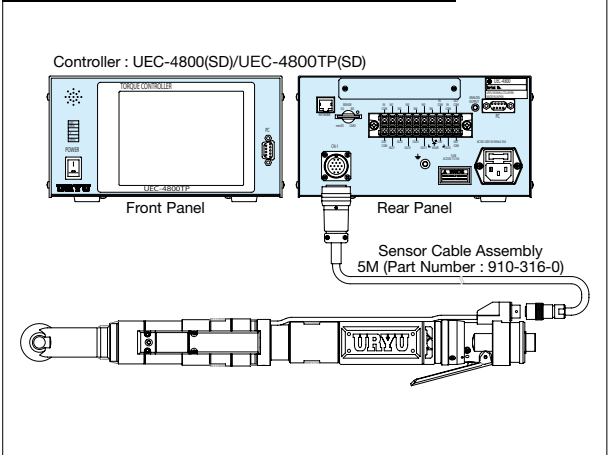

SPECIFICATIONS

Recommended Air Pressure : 0.6MPa (85psi)

Model	Bolt Capacity		Torque Range		Free Speed (about)	Overall Length less Socket (about)		Weight less Socket (about)		From Center to Outside (about)		Angle Height (about)		Square Drive Shank		Average Air Consumption	
	mm	in	Nm	ft-lbs	rpm	mm	in	kg	lb	mm	in	mm	in	mm	in	m ³ /min	ft ³ /min
UAN-611RM-60C	6	1/4	6.5-12.0	4.3-8.6	620	419	16 1/2	2.0	4.4	14.0	35/64	47	1 55/64	9.5	3/8	0.6	21.2
UAN-611RM-50C	6-8	1/4-5/16	8.5-15.0	5.7-10.8	470	409	16 7/64	2.0	4.4	14.0	35/64	47	1 55/64	9.5	3/8	0.6	21.2
UAN-611RM-40C	6-8	1/4-5/16	10.0-18.0	7.2-12.9	400	409	16 7/64	2.0	4.4	14.0	35/64	47	1 55/64	9.5	3/8	0.6	21.2
UAN-611RM-30C	8	5/16	13.0-25.0	9.3-18.0	270	409	16 7/64	2.0	4.4	14.0	35/64	47	1 55/64	9.5	3/8	0.6	21.2
UAN-701RM-60C	8	5/16	20.0-31.0	14.5-23.1	600	480	18 57/64	2.7	5.94	14.0	35/64	47	1 55/64	9.5	3/8	0.9	31.8
UAN-701RM-40C	8-10	5/16-3/8	28.0-45.0	21.0-33.3	400	492	19 3/8	2.9	6.38	18.0	45/64	51	2	9.5	3/8	0.9	31.8
UAN-701RM-30C	10-12	3/8-1/2	37.0-60.0	27.5-44.1	300	492	19 3/8	2.9	6.38	18.0	45/64	58	2 9/32	12.7	1/2	0.9	31.8

Air Inlet Thread (Pipe Tap) : NPT1/4" Air Hose Size (Inside Diameter) : 9.5mm (3/8")

SPECIFICATIONS

Recommended Air Pressure : 0.6MPa (85psi)

Model	Bolt Capacity		Torque Range		Free Speed (about)	Overall Length (about)		Weight less Socket (about)		From Center to Outside (about)		Angle Height (about)		Square Drive Shank		Average Air Consumption	
	mm	in	Nm	ft-lbs	rpm	mm	in	kg	lb	mm	in	mm	in	mm	in	m ³ /min	ft ³ /min
UAN-611R-60C	6	1/4	6.5-12.0	4.3-8.6	620	383	15 5/64	1.6	3.52	14.0	35/64	47	1 55/64	9.5	3/8	0.6	21.2
UAN-611R-50C	6-8	1/4-5/16	8.5-15.0	5.7-10.8	470	373	14 11/16	1.6	3.52	14.0	35/64	47	1 55/64	9.5	3/8	0.6	21.2
UAN-611R-40C	6-8	1/4-5/16	10.0-18.0	7.2-12.9	400	373	14 11/16	1.6	3.52	14.0	35/64	47	1 55/64	9.5	3/8	0.6	21.2
UAN-611R-30C	8	5/16	13.0-25.0	9.3-18.0	270	373	14 11/16	1.6	3.52	14.0	35/64	47	1 55/64	9.5	3/8	0.6	21.2
UAN-701R-60C	8	5/16	20.0-31.0	14.5-23.1	600	445	17 33/64	2.4	5.29	14.0	35/64	47	1 55/64	9.5	3/8	0.9	31.8
UAN-701R-40C	8-10	5/16-3/8	28.0-45.0	21.0-33.3	400	455	17 29/32	2.4	5.29	18.0	45/64	51	2	9.5	3/8	0.9	31.8
UAN-701R-30C	10-12	3/8-1/2	37.0-60.0	27.5-44.1	300	455	17 29/32	2.4	5.29	18.0	45/64	58	2 9/32	12.7	1/2	0.9	31.8

Air Inlet Thread (Pipe Tap) : NPT1/4" Air Hose Size (Inside Diameter) : 9.5mm (3/8") Fastening count is available with UTM-1500, as an option.

IMPACT WRENCHES

Optimal Torque of Bolt

The optimal torque of bolt is based on the clamp force achieved. The clamp force applied to bolt should not exceed 70% of the proof load of bolt and the optimal torque applied to bolt should be as much as 60% of the proof load. See the following equation to calculate the optimal torque.

$$T = k \cdot D \cdot N \quad \text{Torque} = \text{Coefficient of friction} \times \text{Nominal Diameter} \times \text{Clamp Force (Tension)}$$

Property Class	4.8		5.8		6.8		8.8		10.9		12.9	
Nominal Diameter	Torque (Nm)	Proof Load (N)	Torque (Nm)	Proof Load (N)	Torque (Nm)	Proof Load (N)	Torque (Nm)	Proof Load (N)	Torque (Nm)	Proof Load (N)	Torque (Nm)	Proof Load (N)
M3	0.6	1560	0.8	1910	0.9	2210	1.2	2920	1.7	4180	2.0	4880
M4	1.4	2720	1.8	3340	2.0	3860	2.7	5100	4.0	7290	4.6	8520
M5	2.9	4400	3.6	5400	4.1	6250	5.5	8230	8.0	11800	9.4	13800
M6	4.9	6230	6.1	7640	7.0	8840	9.3	11600	13.6	16700	15.9	19500
M8	12.0	11400	14.8	13900	16.9	16100	22.5	21200	33.0	30400	38.7	35500
M10	23.7	18000	29.2	22000	33.4	25500	44.6	33700	65.4	48100	76.6	56300
M12	41.3	26100	51.0	32000	58.3	37100	77.7	48900	114.1	70000	133.5	81800
M14	65.7	35600	81.2	43700	92.7	50600	123.7	66700	181.6	95500	212.5	112000
M16	102.5	48700	126.6	59700	144.7	69100	192.9	91000	283.4	130000	331.6	152000
M18	141.0	59500	174.2	73000	199.1	84500	273.7	115000	389.8	159000	456.2	186000
M20	199.9	76000	247.0	93100	282.2	108000	388.1	147000	552.7	203000	646.8	238000
M22	272.0	93900	336.0	115000	384.0	133000	528.0	182000	751.9	252000	879.9	294000
M24	345.7	109000	427.0	134000	488.0	155000	671.0	212000	955.7	293000	1118.3	342000
M27	505.6	142000	624.6	174000	713.8	202000	981.5	275000	1397.9	381000	1635.9	445000
M30	686.7	174000	848.2	213000	969.4	247000	1332.9	337000	1898.4	466000	2221.6	544000
M33	934.4	215000	1154.3	264000	1319.2	305000	1813.8	416000	2583.4	576000	3023.1	673000

The torque values listed are based on the clamp force (tension) applied to hexagon metric coarse thread bolt and coefficient of friction 0.2 (guidance only). Select the best tool for your application.

Model name of Impact Wrenches

Example	UW	-	6SH	L	K
			6SH (pistol grip for 6mm bolt*) 6SSH (straight handle) 6CSH (angle head) 6AS (45 degree angle head) ST (for stud bolt) P (pistol grip only for UW-140 · 220 · 381 series)	L (long anvil) R (rear exhaust)	K (light weight) DK (driver type anvil · light weight)

*Exception: UW-140 series =14mm bolt, UW-220 series =22mm, UW-381 series=38mm, UW-401 series=40mm and UW-550 = 55 mm

Socket Retaining Methods

Please specify the type of Anvil when ordering.

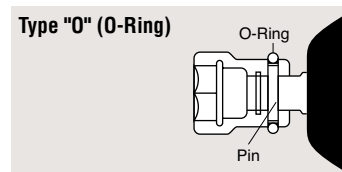
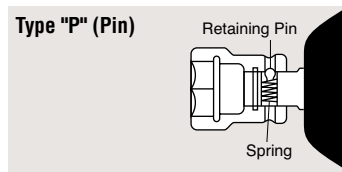
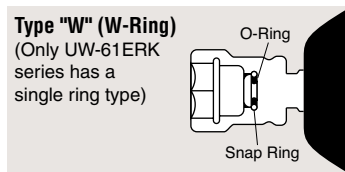

Double-Hammer mechanism

Powerful & fast assembly for highest productivity with well-balanced hammer mechanism and less torque reaction to operator. Recommended for general high-volume assembly such as motor vehicles, appliances, machinery and so forth.

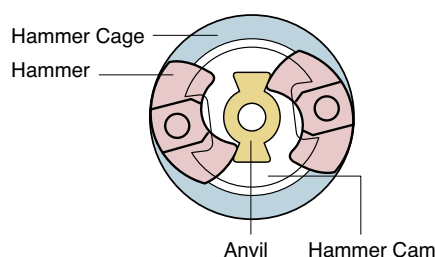

Swing-Hammer mechanism

Powerful & durable impacting mechanism with one piece Hammer-Hammer pin. Recommended to steel erection, refineries, mines, heavy motor vehicle industries and etc. (UW-140P, 220P, 251P, and 381 series)

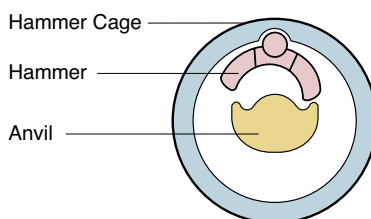

TORQUE CHART

To avoid excess wear of the parts, the tightening time is recommended not to exceed 5 seconds.

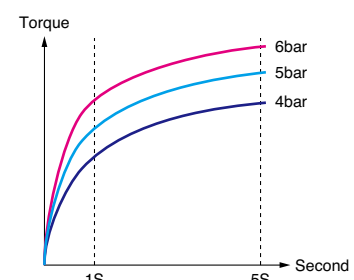

RECOMMENDED TORQUE CHART OF THE IMPACT WRENCHES

Fastening force of the impact wrenches changes in accordance to the fastening time and the bolt size.

This table shows various common fastening torque. Please use this table as just guide line when selecting the model.

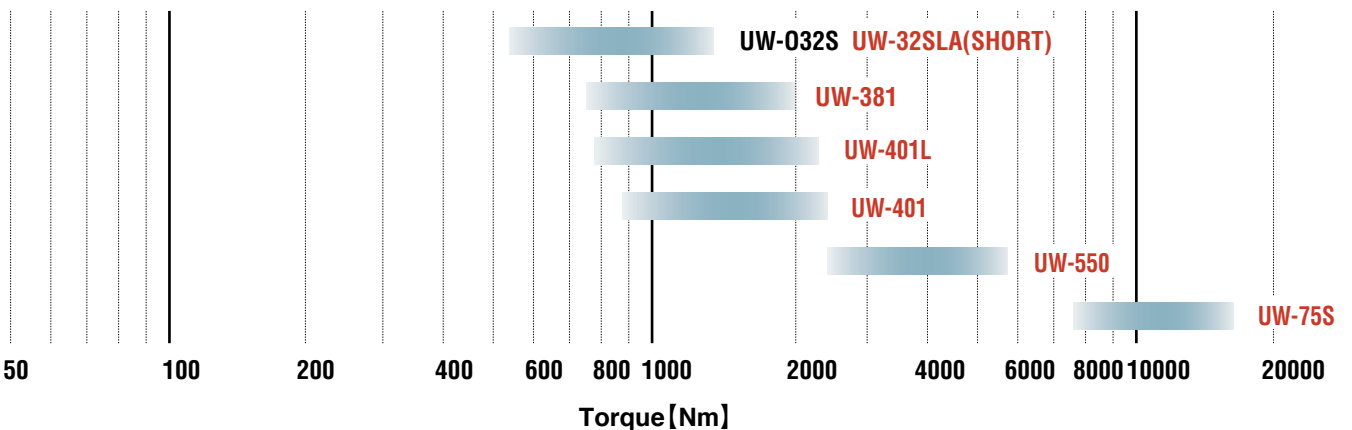
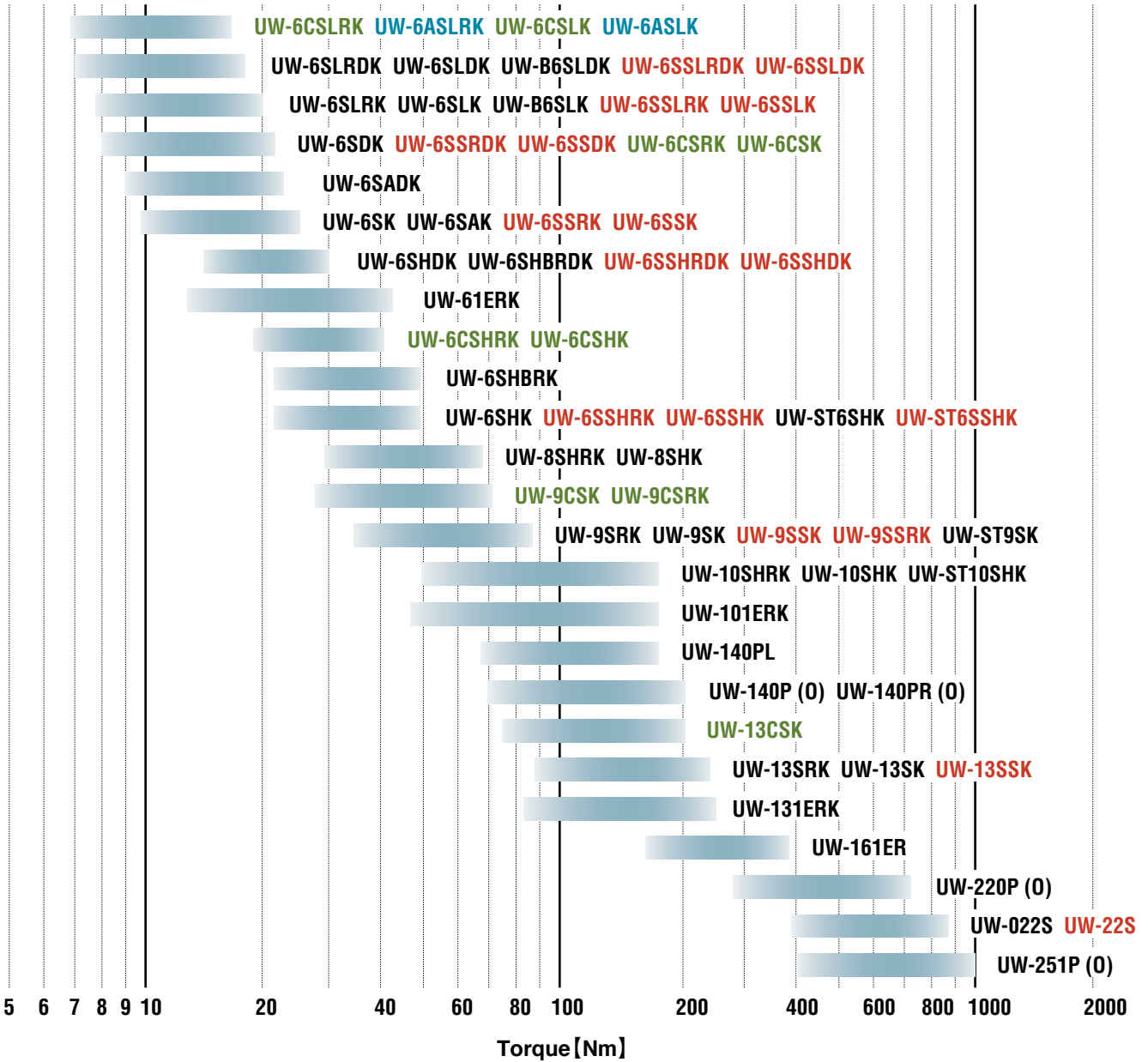
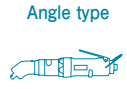
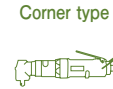
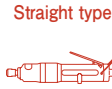

IMPACT WRENCHES

The widest range of URYU Impact Wrenches offer fast, powerful and economical operation in high-volume heavy assembly applications.



UW-6SLRK



UW-61ERK



UW-101ERK



UW-161ER



UW-6SHBRK



UW-B6SLK



UW-8SHRK



UW-10SHRK



UW-9SRK



UW-13SRK



Front exhaust type (model which does not have "R" in model name.)

Quick-change driver anvil type

On pulling the sleeve, insert or take off the bit.

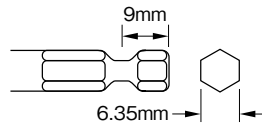

Please add "D" to each model name like UW-6SDK when ordering.

Built-in AIR REGULATOR FOR UW-61ERK,101ERK,131ERK, AND UW-161ER

Set "4" at the arrow mark for strongest and "1" for weakest.

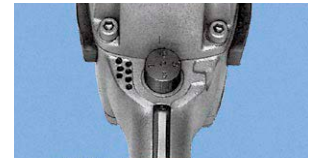

SPECIFICATIONS

Recommended Air Pressure : 0.6MPa (85psi)

Model	Capacity (Nominal Bolt Size)		Free Speed (about)	Overall Length less Socket or Bit (about)		Weight less Socket or Bit (about)		From Center to Outside (about)		Sq. Drive or Hex. Size		Average Air Consumption	
	mm	in		mm	in	kg	lb	mm	in	mm	in	m ³ /min	ft ³ /min
UW-6SLRK	6	1/4	8500	175	6 57/64	0.97	2.13	31.0	1 7/32	9.5	3/8	0.35	12.4
UW-6SHBRK	8	5/16	7300	154	6 1/16	1.36	2.99	28.0	1 7/64	9.5	3/8	0.35	12.4
UW-6SLK	6	1/4	8500	175	6 57/64	0.97	2.13	31.0	1 7/32	9.5	3/8	0.30	10.5
UW-B6SLK	6	1/4	8500	166	6 17/32	0.97	2.13	31.0	1 7/32	9.5	3/8	0.30	10.5
UW-6SK	6	1/4	7500	170	6 11/16	1.22	2.68	27.5	1 5/64	9.5	3/8	0.30	10.5
UW-6SAK	6	1/4	7500	134	5 9/32	1.10	2.47	27.5	1 5/64	9.5	3/8	0.30	10.5
UW-6SHK	8	5/16	7500	173	6 51/64	1.41	3.10	28.0	1 7/64	9.5	3/8	0.35	12.4
UW-8SHRK	8	5/16	7300	172	6 49/64	1.55	3.41	31.0	1 7/32	12.7	1/2	0.40	14.0
UW-9SRK	10	3/8	7000	178	7 1/64	1.79	3.93	34.0	1 11/32	12.7	1/2	0.45	16.0
UW-10SHRK	10-12	3/8-1/2	6000	183	7 13/64	2.13	4.68	35.0	1 3/8	12.7	1/2	0.45	16.0
UW-13SRK	13	1/2	6000	215	8 15/32	2.61	5.74	37.5	1 15/32	12.7	1/2	0.45	16.0
UW-8SHK	8	5/16	7500	172	6 49/64	1.55	3.41	31.0	1 7/32	12.7	1/2	0.40	14.0
UW-9SK	10	3/8	7000	178	7 1/64	1.84	4.04	34.0	1 11/32	12.7	1/2	0.50	17.6
UW-10SHK	10-12	3/8-1/2	6500	183	7 13/64	2.13	4.68	35.0	1 3/8	12.7	1/2	0.45	16.0
UW-13SK	13	1/2	6500	215	8 15/32	2.61	5.74	37.5	1 15/32	12.7	1/2	0.55	19.4

Air Hose Size (Inside Diameter) : 9.5mm (3/8")

Air Inlet Thread : NPT1/4"

SPECIFICATIONS

Recommended Air Pressure:0.6MPa(85psi)

Model	Capacity (Nominal Bolt Size)		Free Speed (about)	Overall Length less Socket (about)		Weight less Socket (about)		From Center to Outside (about)		Sq. Drive Shank		Average Air Consumption	
	mm	in		mm	in	kg	lb	mm	in	mm	in	m ³ /min	ft ³ /min
UW-61ERK	8	5/16	7300	150	5 29/32	1.51	3.32	29.5	1 5/32	9.5	3/8	0.35	12.4
UW-101ERK	10	3/8	5500	179	7 3/64	2.27	4.99	36.0	1 27/64	12.7	1/2	0.45	16.0
UW-131ERK	13	1/2	5500	205	8 5/64	2.97	6.53	37.5	1 15/32	12.7	1/2	0.55	19.4
UW-161ER	16	5/8	3800	217	8 35/64	4.10	9.00	41.5	1 41/64	19.0	3/4	0.65	23.0

Air Hose Size (Inside Diameter) : 12.7mm (1/2") for UW-161ER 9.5mm (3/8") for UW-61ERK, 101ERK & 131ERK series
Air Inlet Thread (Pipe Tap) : NPT 3/8" for 161ER NPT 1/4" for UW-61ERK, 101ERK & 131ERK series



UW-6SSLRK



UW-32SLA (OUT-SHORT)



UW-401L (OUT-1)



UW-22S (SHORT)



UW-6SSHRK



UW-6CSLRK



UW-9SSK



UW-6CSHRK



UW-6ASLRK



UW-13CSK

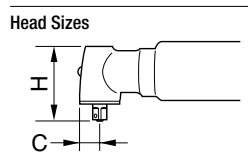

Model	C		H	
	mm	in	mm	in
UW-6CSLRK	13.5	17/32	59.5	2 11/32
UW-6CSRK	15.0	19/32	60.0	2 23/64
UW-6CSHRK	17.5	11/16	65.0	2 9/16
UW-6CSLK	13.5	17/32	59.5	2 11/32

Model	C		H	
	mm	in	mm	in
UW-6CSK	15.0	19/32	60.0	2 23/64
UW-6CSHK	17.5	11/16	65.0	2 9/16
UW-9CS(R)K	22.0	7/8	85.0	3 11/32
UW-13CSK	26.0	11/32	102.0	4 7/32

SPECIFICATIONS

Recommended Air Pressure : 0.6MPa (85psi)

Model	Capacity (Nominal Bolt Size)		Free Speed (about)	Overall Length less Socket or Bit (about)		Weight less Socket or Bit (about)		From Center to Outside (about)		Sq. Drive or Hex. Size		Average Air Consumption	
	mm	in		mm	in	kg	lb	mm	in	mm	in	m ³ /min	ft ³ /min
UW-6SSLRK	6	1/4	8500	239	9 13/32	0.87	1.91	31.0	1 7/32	9.5	3/8	0.30	10.5
UW-6SSRK	6	1/4	7500	225	8 55/64	0.97	2.13	29.5	1 5/32	9.5	3/8	0.30	10.5
UW-6SSHRK	8	5/16	7300	249	9 51/64	1.26	2.77	27.5	1 5/64	9.5	3/8	0.35	12.4
UW-6SSLK	6	1/4	8500	197	7 3/4	0.87	1.91	31.0	1 7/32	9.5	3/8	0.30	10.5
UW-6SSK	6	1/4	7500	184	7 1/4	0.97	2.13	28.0	1 7/64	9.5	3/8	0.30	10.5
UW-6SSHK	8	5/16	7500	203	7 63/64	1.21	2.66	27.5	1 5/64	9.5	3/8	0.35	12.4
UW-6CSLRK	6	1/4	8000	258	10 57/32	1.17	2.57	31.0	1 7/32	9.5	3/8	0.30	10.5
UW-6CSRK	6	1/4	7300	257	10 1/8	1.42	3.12	29.5	1 5/32	9.5	3/8	0.30	10.5
UW-6CSHRK	8	5/16	7300	282	11 7/64	1.71	3.76	27.5	1 5/64	9.5	3/8	0.30	10.5
UW-6ASLRK	6	1/4	6500	277	10 29/32	1.14	2.50	31.0	1 7/32	9.5	3/8	0.30	10.5
UW-6CSLK	6	1/4	8000	217	8 35/64	1.17	2.57	31.0	1 7/32	9.5	3/8	0.30	10.5
UW-6CSK	6	1/4	7500	218	8 37/64	1.42	3.12	28.0	1 7/64	9.5	3/8	0.30	10.5
UW-6CSHK	8	5/16	7500	238	9 3/8	1.71	3.76	27.5	1 5/64	9.5	3/8	0.35	12.4
UW-6ASLK	6	1/4	6500	235	9 1/4	1.14	2.50	31.0	1 7/32	9.5	3/8	0.30	10.5
UW-9SSK	10	3/8	7000	290	11 27/64	2.10	4.62	34.0	1 11/32	12.7	1/2	0.45	16.0
UW-9SSRK	10	3/8	7000	320	12 19/32	2.10	4.62	34.0	1 11/32	12.7	1/2	0.45	16.0
UW-13SSK	13	1/2	6300	281	11 1/16	3.17	6.97	39.0	1 17/32	12.7	1/2	0.55	19.4
UW-9CSK	10	3/8	7000	337	13 17/64	2.78	6.11	34.0	1 11/32	12.7	1/2	0.35	12.4
UW-9CSRK	10	3/8	7000	359	14 9/64	2.78	6.11	34.0	1 11/32	12.7	1/2	0.35	12.4
UW-13CSK	13	1/2	6500	374	14 23/32	5.17	11.37	39.0	1 17/32	12.7	1/2	0.75	26.5

Air Hose Size (Inside Diameter) : 9.5mm (3/8") Air Inlet Thread : NPT1/4"

SPECIFICATIONS

Recommended Air Pressure : 0.6MPa (85psi)

Model	Capacity (Nominal Bolt Size)		Free Speed (about)	Overall Length less Socket (about)		Weight less Socket (about)		From Center to Outside (about)		Sq. Drive Shank		Average Air Consumption	
	mm	in		mm	in	kg	lb	mm	in	mm	in	m ³ /min	ft ³ /min
UW-22S	22	7/8	4000	395	15 35/64	7.90	17.41	50.0	1 31/32	19.0	3/4	0.75	26.5
UW-22S(L)	22	7/8	4000	518	20 25/64	8.30	18.30	50.0	1 31/32	19.0	3/4	0.75	26.5
UW-O22S	22	7/8	3800	257	10 1/8	7.65	16.80	50.0	1 31/32	19.0	3/4	0.75	26.5
UW-O32S	32	1 1/4	3500	304	11 31/32	11.60	25.50	61.0	2 13/32	25.4	1	1.15	40.6
UW-32SLA	32	1 1/4	3500	438	17 1/4	11.70	25.74	62.5	2 29/64	25.4	1	0.90	32.0
UW-32SLA(L)	32	1 1/4	3500	583	22 61/64	12.50	27.50	62.5	2 29/64	25.4	1	0.90	32.0
UW-401	38	1 1/2	3200	494	19 29/64	15.10	33.22	62.5	2 29/64	25.4	1	1.20	42.4
UW-401L	38	1 1/2	3200	654	25 3/4	16.50	36.30	62.5	2 29/64	25.4	1	1.20	42.4

Air Hose Size (Inside Diameter) : 12.7mm (1/2")
Air Inlet Thread : NPT3/8" for UW-22S, UW-O22S & UW-O32S NPT1/2" for UW-32SLA & UW-401

IMPACT WRENCHES

SWING HAMMER SERIES

BOLT & NUT SETTERS



UW-140PR



UW-140P



UW-220P



UW-251P



UW-381



Suffix "L" to Model Name.

Head Sizes

Model	L		Model	L	
	mm	in		mm	in
UW-140PL	68.5	2 45/64	UW-381L	200.0	7 7/8
UW-220PL	150.0	5 29/32	UW-381PL	200.0	7 7/8
UW-251PL	151.0	5 15/16	UW-401L	199.5	7 55/64

SPECIFICATIONS

Recommended Air Pressure : 0.6MPa (85psi)

Model	Capacity (Nominal Bolt Size)		Free Speed (about)	Overall Length less Socket (about)		Weight less Socket (about)		From Center to Outside (about)		Sq. Drive Shank		Average Air Consumption	
	mm	in		rpm	mm	in	kg	lb	mm	in	mm	in	m ³ /min
UW-140P, -140PR	12	1/2	6500	200	7 7/8	2.70	5.90	33.0	1 19/64	12.7	1/2	0.70	25.0
UW-140PL, -140PRL	12	1/2	6800	244	9 39/64	2.80	6.10	33.0	1 19/64	12.7	1/2	0.70	25.0
UW-220P	22	7/8	5500	230	9 1/16	4.40	9.60	42.0	1 21/32	19.0	3/4	0.70	25.0
UW-220PL	22	7/8	5500	350	13 25/32	4.70	10.30	42.0	1 21/32	19.0	3/4	0.70	25.0
UW-251P	25	1	5500	276	10 55/64	8.00	17.60	51.5	2 1/32	25.4	1	0.80	28.0
UW-251PL	25	1	5500	395	15 35/64	8.80	19.40	51.5	2 1/32	25.4	1	0.80	28.0
UW-381	38	1 1/2	4700	395	15 35/64	9.50	20.90	58.5	2 19/64	25.4	1	0.90	31.5
UW-381L	38	1 1/2	4700	543	21 3/8	10.00	22.00	58.5	2 19/64	25.4	1	0.90	31.5
UW-381P	38	1 1/2	4700	276	10 55/64	9.50	20.90	58.5	2 19/64	25.4	1	0.90	31.5
UW-381PL	38	1 1/2	4700	425	16 47/64	10.00	22.00	58.5	2 19/64	25.4	1	0.90	31.5

Air Hose Size (Inside Diameter) : 9.5mm(3/8") for UW-140P Series, 12.7mm (1/2") for other models above

Air Inlet Thread : NPT 1/4" for UW-140P series

NPT 3/8" for UW-220P, UW-251P Series

NPT 1/2" for UW-381 Series

UW-140P Series combine compact size and light weight with torque, 70 – 200 Nm to meet a wide range of applications. Recommendable for overall automotive service, body shop etc.

UW-220P Series are recommendable for various popular fastening joints in general industry. (300-700Nm)

UW-251P Series are recommendable for heavy industrial production work such as engine work, truck springs, tractor pads, off-road equipment and heavy duty farm equipment.(600 – 1000Nm)

UW-381 Series are powerful, light-weight impact wrenches that are ideal for wide applications (1400 - 2000 Nm) in steel erection refineries, petrochemical plants, mines, steel mills and heavy motor vehicle plants.

JUMBO TYPE IMPACT WRENCHES

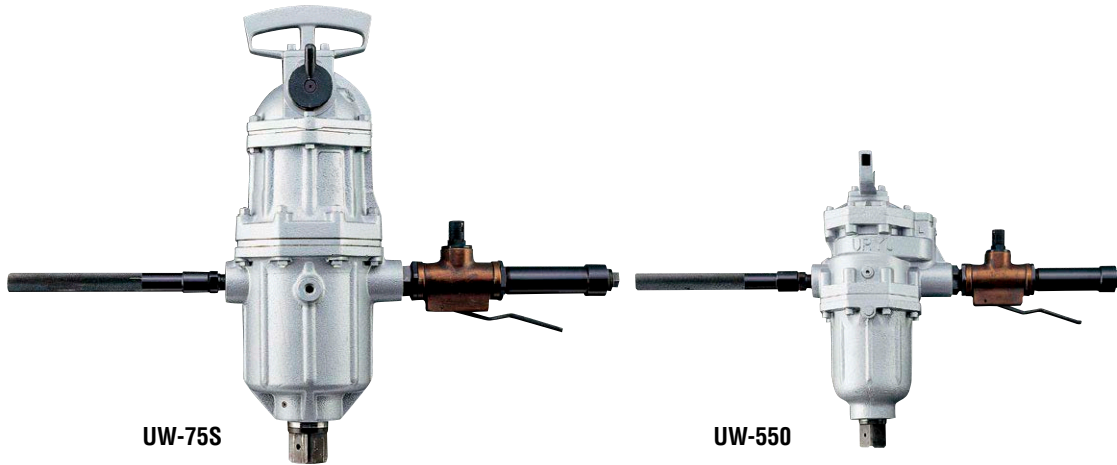

Built-In Air Regulator

Pull up the spring loaded knob and turn clockwise to lower the power and anticlockwise to increase it, then reset.

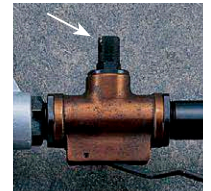

SPECIFICATIONS

Recommended Air Pressure : 0.6MPa (85psi)

Model	Capacity (Nominal Bolt Size)		Free Speed (about)	Overall Length less Socket (about)		Weight less Socket (about)		From Center to Outside (about)		Sq. Drive Shank		Average Air Consumption	
	mm	in		mm	in	kg	lb	mm	in	mm	in	m ³ /min	ft ³ /min
UW-550	55	2 1/4	3500	525	20 43/64	36.0	79.2	78.0	3 5/64	38.1	1 1/2	2.20	79
UW-75S	75	3	1400	670	26 3/8	56.0	123.0	96.0	3 25/32	44.4	1 3/4	3.20	114
UW-75S (1 1/2)	76	3	1400	670	26 3/8	56.0	123.0	96.0	3 25/32	38.1	1 1/2	3.20	114

Air Hose Size (Inside Diameter) : 19.0 mm (3/4")
Air Inlet Thread : NPT1"

STUD BOLT WRENCHES

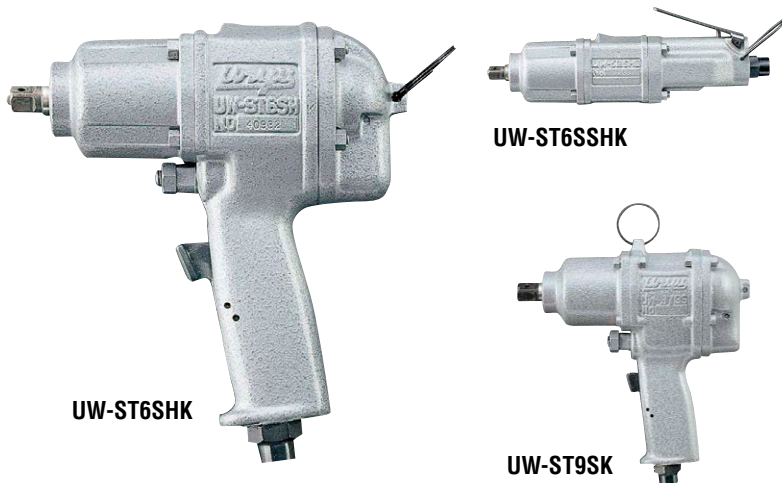

FEATURES

Double-Hammer Auto-Reversing for Stud Bolt Driving

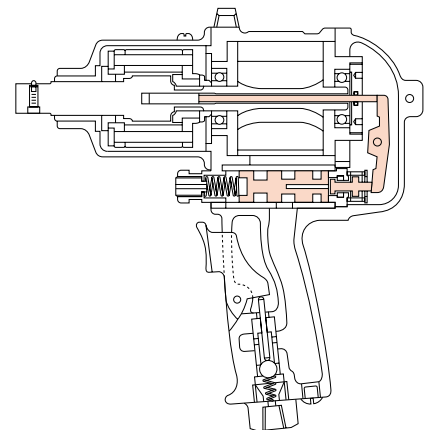

These unique Auto-Reversing tools simply stud-bolt driving (frequent reversing) job considerably for less operator's fatigue & high productivity. Push the tool forward to the work for driving and simply pull it back.

SPECIFICATIONS

Recommended Air Pressure : 0.6MPa (85psi)

Model	Capacity (Nominal Bolt Size)		Free Speed (about)	Overall Length less Socket (about)		Weight less Socket (about)		From Center to Outside (about)		Sq. Drive Shank		Average Air Consumption	
	mm	in		mm	in	kg	lb	mm	in	mm	in	m ³ /min	ft ³ /min
UW-ST6SHK	8	5/16	6500	171	6 47/64	1.70	3.74	28.5	1 1/8	9.5	3/8	0.40	14.0
UW-ST9SK	10	3/8	6300	192	7 9/16	2.35	5.06	33.5	1 5/16	12.7	1/2	0.50	17.6
UW-ST10SHK	10-12	3/8-1/2	6300	194	7 41/64	2.60	5.72	33.5	1 5/16	12.7	1/2	0.50	17.6
UW-ST6SSHK	6-8	1/4-5/16	6500	235	9 1/4	1.35	2.97	28.5	1 1/8	9.5	3/8	0.40	14.0

Air Hose Size (Inside Diameter) : 9.5mm (3/8")
Air Inlet Thread : NPT1/4"

UTM-1500 SERIES

UTM-1500 informs you of error by display and buzzer when all bolts are not tightened up firmly. This enables you to do "Pokayoke" for secure tightening.



UTM-1500(PS): Pressure Sensor Incorporated type
By connecting the TM signal hose from a tool to the coupler at the back of the controller, the pressure sensor incorporated in the controller converts the air pressure signal into the electric signal.



UTM-1500(CN): Connector Incorporated type
By connecting the pressure sensor (external pressure sensor assembly) attached to a tool to the connector at the back of controller, the controller supplies the power and loads the analog signal.

FEATURES

- Applicable to the pneumatic tools such as the oil pulse wrenches, impact wrenches etc., or the electric tools, UDP-TA series. (Tool should be modified into the TM type because the controller basically detects the back pressure.)
- Counting down the fastening number, error proofing by the display and buzzer.
- Easy parameter setup the controller by front key switches followed to the front panel LCD. (It is possible to setup the parameters through a personal computer as well.) *TM convertible model : Various kinds of tools can be converted into TM type. Please ask your local URYU distributor for details.

[FUNCTIONS]

- Easy setup for the pressure values by the automatic setup future.
- Up to 1500 tightening time and judging data points stored.
- Each buzzer volume level of fastening recognition, panel and NOK operation adjustable.
- Work select feature available for four different works with different numbers of fasteners.
- By equipping the external input/output terminal block (free format), inter lock with the line is possible.
- Parameters receivable/ transmittable, and wave data, memory data and the total numbers of fasteners receivable through PC.(Total numbers of pulse receivable in usage of the external pressure sensor assembly.)
- Measurement and display of the fastening time possible for the shut off tools.
- External pressure sensor assembly equipped for UTM-1500(CN) enables to count the pulse number so that the pulse number control becomes possible other than the fastening time control. (The pulse number cannot be detected sometimes depending on a tool or working conditions.)
- Total maintenance determined the total numbers of fasteners or pulse possible. (external pressure sensor assembly needed.)

UTM-1500 (RA) :
Rack Type



Model	Voltage & Frequency	Operating ambient temperature & humidity	Dimensions mm(in)	Weight Kg(lb)
UTM-1500A/E (PS)	115V / 230V 50Hz / 60Hz	0 - 50 degree (no freeze) less 90%RH (no dewfall)	200 × 210 × 100 (7 7/8 × 8 17/64 × 3 15/16)	2.0 (4.47)
UTM-1500A/E (CN)				2.0 (4.47)
UTM-1500A/E (RA-PS)	115V / 230V 50Hz / 60Hz	0 - 50degree (no freeze) less 90%RH (no dewfall)	280 × 220 × 420 (11 1/32 × 8 21/32 × 16 17/32) (c/w rack)	6.4 (14.15)
UTM-1500A/E (RA-CN)				6.4 (14.15)

* TM convertible model : Various kinds of tools can be converted into TM type. Please ask your local URYU distributor for details.
UTM-1500A is the 115V use, while UTM-1500E is the 230V use.

OPTION

Twin Spiral Hose Assembly

Twin Spiral Hose Assembly : Please ask your local URYU distributor for details.

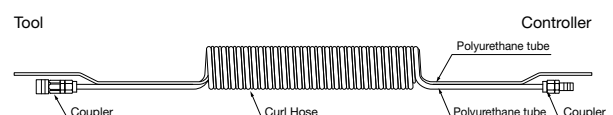

TM Tool Connection

Shut-off Tool

- UTM-1500(CN) & External Pressure Sensor Assembly
*Please place the external pressure sensor assembly to a tool as close as possible. In use of the pulse number count, external pressure sensor assembly should be attached near a tool handle.

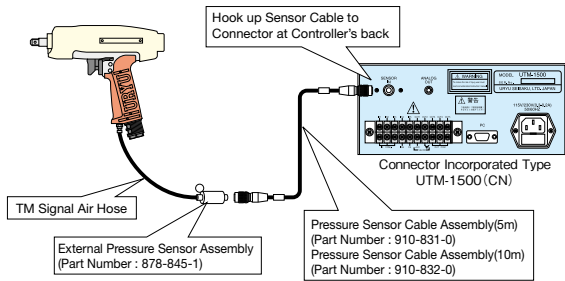

- UTM-1500(RA-CN) & External Pressure Sensor Assembly
*Same wiring as in the case of UTM-1500(CN) & External Pressure Sensor Assembly (left figure)

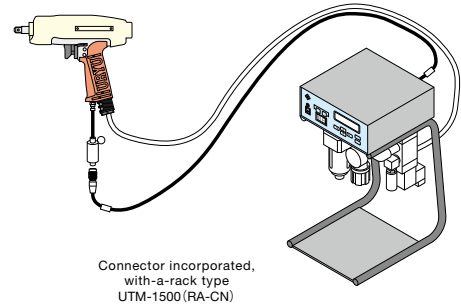

- UTM-1500(PS)

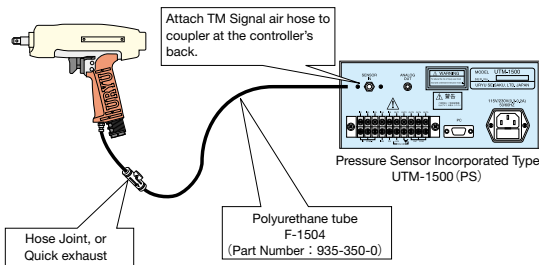

- UTM-1500(PS) or (CN) & Relay Box Assembly

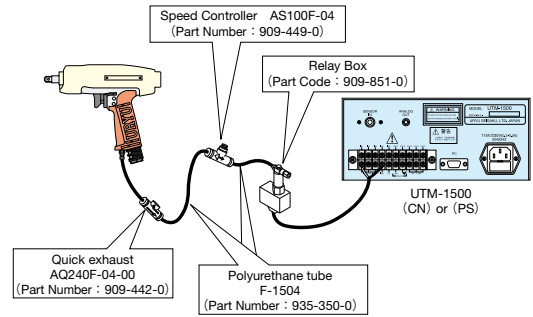

- UDP-TA Series & UTM-1500

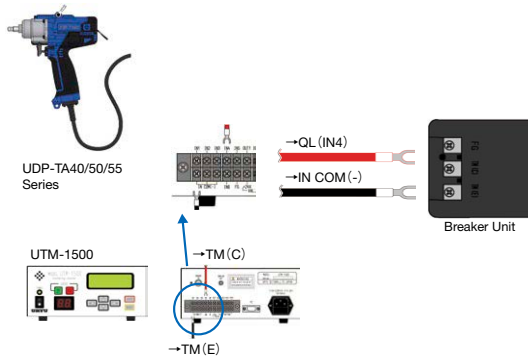

Non Shut-off Tool

- UTM-1500(CN)
Solenoid valve is incorporated in the rack type, UTM-1500(RA-CN), so that you only need to connect a tool to controller.

- UTM-1500(PS)
Referring to the right layout, please connect the TM signal Hose(φ4) from a tool to the connector at the back of the controller.

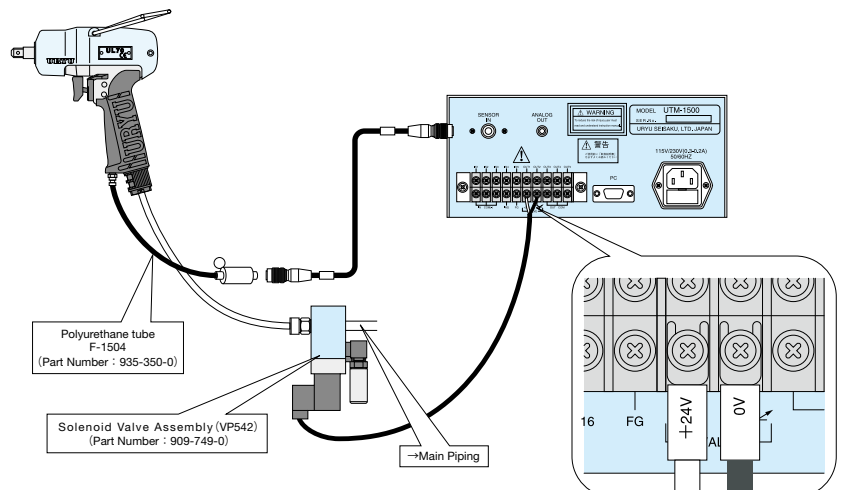

NUTRUNNERS

By transmitting the force of air motor or electric motor to output shaft using only the reduction gear, it makes possible to suppress noise and vibration. Also, it enables an excellent durability.

URYU Multiple Nutrunners are now very popular in various modern industries, especially in automobile assembly lines, where two or more bolts or nuts must be tightened simultaneously uniform torque. URYU can design and manufacture the complete machine to meet customers' demands besides components individual supply. Please feel free to contact local URYU distributors.



Electric Nutrunner



Air Nutrunner and minimum torque sensor

Setting Layout

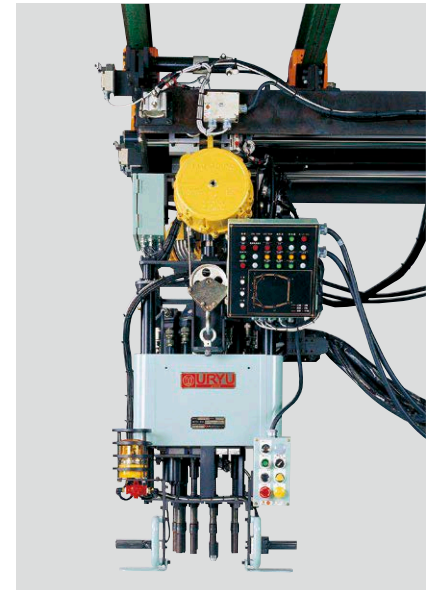
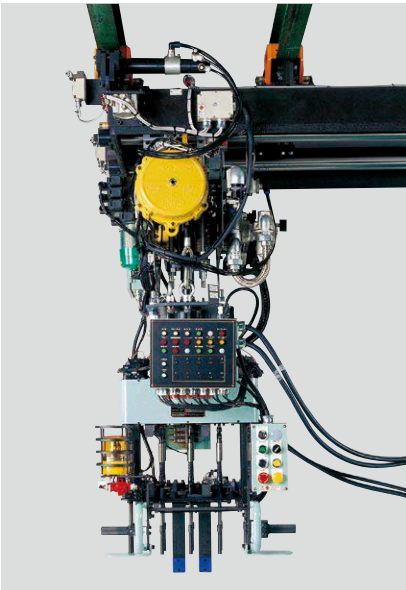

*ISO 9001 is not applied to the nutrunner system

SCREW DRIVERS

TORQUE CONTROL SCREWDRIVERS
CUSHION CLUTCH TYPE SCREWDRIVERS
DIRECT DRIVE SCREWDRIVERS
IMPACT SCREWDRIVERS

SELECTION GUIDE

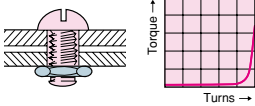
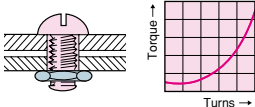
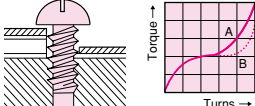
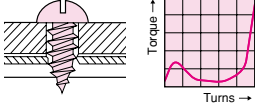
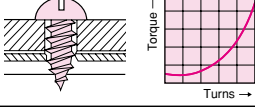
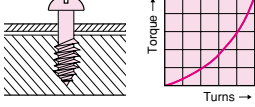
Joint & Torque Curve	Feature	Clutch Type	Model	A	B	C
Free Running Hard Stop 	Turns easily until head seats, then instant resistance to torque build-up.	Oil-Pulse	U & UX	⊙	⊙	⊙
		Oil-Pulse	UAT,ULT & UL	⊙	⊙	⊙
		Impact	UW & US-○○W	×	○	×
		Torque Control	US-LT series	○	⊙	⊙
		Direct Drive	US-LD series	○	○	○
Cushion	Other US series	○	○	○		
Soft Stop 	Turns easily until head seats, Gradual resistance as material compresses.	Oil-Pulse	U & UX	⊙	⊙	⊙
		Oil-Pulse	UAT,ULT & UL	⊙	⊙	⊙
		Impact	UW & US-○○W	×	○	×
		Torque Control	US-LT series	○	⊙	⊙
		Direct Drive	US-LD series	○	○	○
Cushion	Other US series	○	○	○		
Self-Tapping Thick Material 	Constant heavy resistance until head seats. Then gradual or sudden build-up.	Oil-Pulse	U & UX	⊙	○	○
		Impact	UW & US-○○W	×	○	×
		Torque Control	US-LT series	×	×	×
		Direct Drive	US-LD series	○	○	○
		Cushion	Other US series	○	○	○
Self-Tapping Sheet Metal 	Increasing resistance followed by easing then sudden build-up as head seats.	Oil-Pulse	U, UX & UL	⊙	⊙	⊙
		Impact	UW & US-○○W	×	○	×
		Torque Control	US-LT series	×	×	×
		Direct Drive	US-LD series	○	○	○
		Cushion	Other US series	○	○	○
Self-Tapping Plastic 	Constant heavy resistance until head seats. Then gradual or sudden build-up.	Oil-Pulse	U, UX & UL	⊙	⊙	⊙
		Impact	UW & US-○○W	×	×	×
		Torque Control	US-LT series	○	⊙	⊙
		Direct Drive	US-LD series	○	○	○
		Cushion	Other US series	○	○	○
Wood Screws 	Small starting resistance which increases as screw is driven in. Heavier resistance when head seats.	Oil-Pulse	U & UX	○	○	○
		Oil-Pulse	UL	⊙	⊙	⊙
		Impact	UW & US-○○W	×	×	×
		Torque Control	US-LT series	×	×	×
		Direct Drive	US-LD series	○	⊙	⊙
Cushion	Other US series	○	○	○		





Remarks : A=Ergonomics B=Job Efficiency C=Torque Accuracy Recommendation : ⊙=Excellent ○=Good ×=Not Recommended

Accessories

Group of Tools

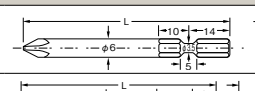
A	US-LT○○A/AL,US-3.5A,US-4,US-40,US-4PB
B	US-○○W/PW,US-450WB,US-LT○○B/BL/PB,US-5,US-50,US-5PB
C	US-LT10B
D	US-LT30B-○○C,US-LT40B-○○C,US-3.5ACB,US-4CA,US-5CA

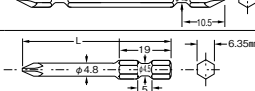
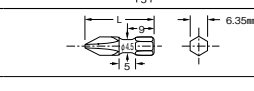
(+) PHILLIPS BITS

Group	Bit	(L)		Part Number		
		mm	In	No.1	No.2	No.3
A		120	4 23/32	916-306-0	916-316-0	916-321-0
B		100	3 15/16	916-401-0	916-411-0	916-421-0
		75	2 61/64	916-800-0	916-810-0	916-820-0
C		50	1 21/32	916-137-0	—	—
D		30	1 37/64	916-501-0	916-511-0	916-521-0

HEXAGONAL WRENCH BIT

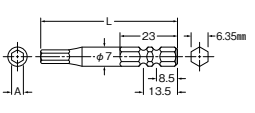
Group	B, C				
BIT					
	Dimensions				Part Number
Dimensions / Part Number	A		(L)		
	mm	in	mm	in	
	4	1/8	75	2 61/64	867-172-1
5	13/64	75	2 61/64	867-176-1	
6	15/64	75	2 61/64	867-121-1	

HEXAGONAL SOCKET BITS

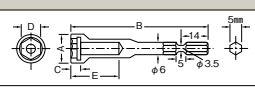
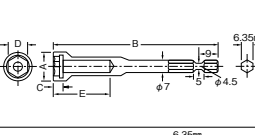
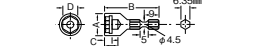
Group	Bit	Dimensions										Part Number
		A		B		C		D		E		
		mm	in	mm	in	mm	in	mm	in	mm	in	
A		12	15/32	100	3 15/16	4.5	11/64	8	5/16	30	1 37/64	918-109-0
B		16	8/5	50	1 31/32	5.5	7/32	10	25/64	15	19/32	918-259-0
		16	8/5	75	2 61/64	5.5	7/32	10	25/64	25	63/64	918-215-0
		16	8/5	100	3 15/16	5.5	7/32	10	25/64	30	1 37/64	918-216-0
		16	8/5	150	5 29/32	5.5	7/32	10	25/64	30	1 37/64	918-237-0
		16	8/5	200	7 7/8	5.5	7/32	10	25/64	30	1 37/64	918-245-0
		18	45/64	100	3 15/16	7	9/32	12	15/32	30	1 37/64	918-222-0
D		16	8/5	31	1 7/32	5.5	7/32	10	25/64	7	9/32	918-307-0

*Please ask your local URYU distributor for other bit size.

SELECTION CHART

Fastening force of the screwdrivers changes in accordance to the fastening time and the bolt size. This table shows various common fastening torque. Please use this table as just guide line when selecting the model.

Pistol Type



Push-Start Type



Lever-Start Type



Angle-Head Type



TORQUE-CONTROL TYPE

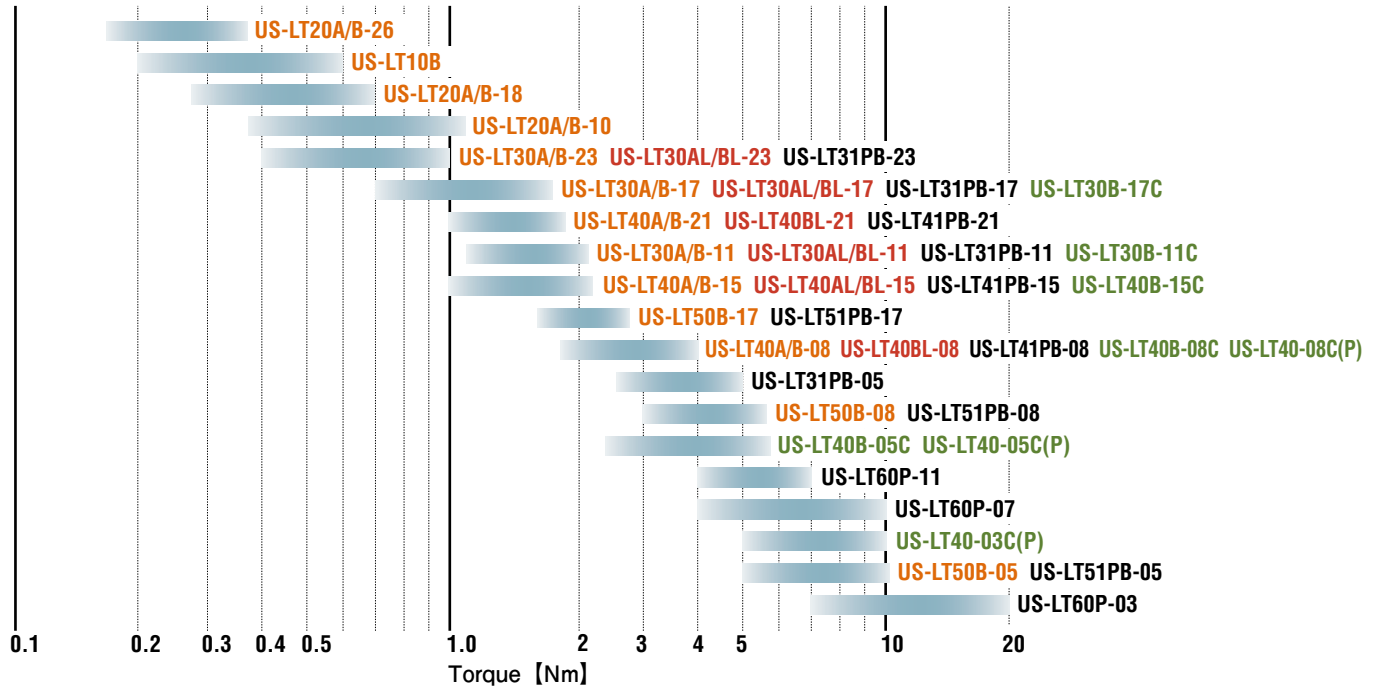

CUSHION CLUTCH TYPE

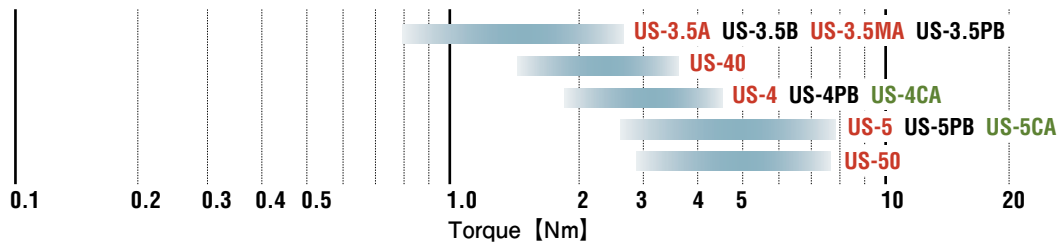

DIRECT DRIVE TYPE

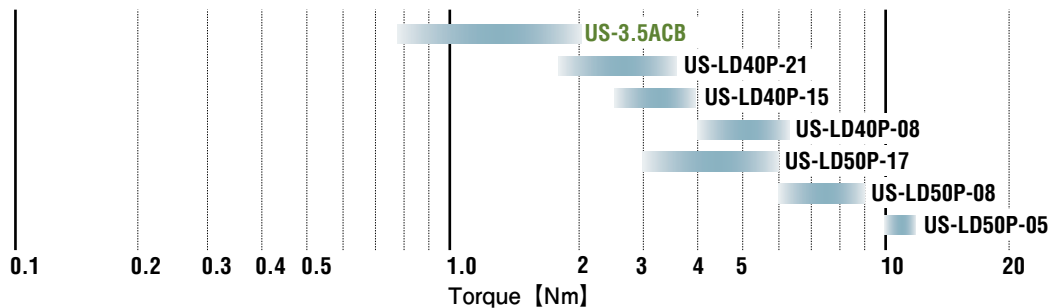

IMPACT TYPE

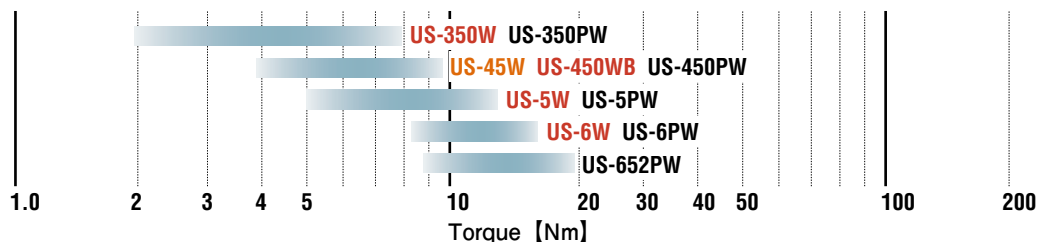

TORQUE CONTROL SCREWDRIVERS

US-LT drivers enable you to set the shut-off torque. These small and light-weight screwdrivers contributes to reducing operators' fatigue and to better productivity.



US-LT10B



US-LT20A-10



US-LT30A-17



US-LT30B-11



US-LT40A-08



US-LT50B-05



US-LT30AL-17



US-LT30BL-11



US-LT40AL-15



US-LT40BL-15



US-LT40BL-08

SPECIFICATIONS

Recommended Air Pressure : 0.5MPa (72psi)

Model	Capacity (Screw Size)		Torque Range		Free Speed (Approx.) rpm	Overall Length (about)		Weight less Bit (about)		From Center to Outside (about)		Air Hose Size (inside Dia.)		Average Air Consumption	
	mm	in	Nm	in-lbs		mm	in	kg	lb	mm	in	mm	in	m ³ /min	ft ³ /min
US-LT10B	2.6	No.3	0.20-0.60	1.8-5.3	1000	191	7 33/64	0.29	0.63	12.0	31/64	6.35	1/4	0.15	5.2
US-LT20A(B)-26	2.2	No.2	0.15-0.35	1.3-3.1	2600	180	7 3/32	0.34	0.68	13.0	33/64	6.35	1/4	0.16	5.6
US-LT20A(B)-18	2.6	No.3	0.25-0.70	2.2-6.2	1800	180	7 3/32	0.34	0.68	13.0	33/64	6.35	1/4	0.16	5.6
US-LT20A(B)-10	3	No.5	0.35-1.10	3.1-9.68	1000	180	7 3/32	0.34	0.68	13.0	33/64	6.35	1/4	0.16	5.6
US-LT30A(B)-23	3	No.5	0.40-1.00	3.5-8.8	2300	187	7 23/64	0.43	0.94	15.5	39/64	6.35	1/4	0.20	7.0
US-LT30A(B)-17	3.5	No.6	0.70-1.50	6.2-13.2	1700	187	7 23/64	0.43	0.94	15.5	39/64	6.35	1/4	0.20	7.0
US-LT30A(B)-11	4	No.8	1.10-2.10	9.7-18.5	1100	187	7 23/64	0.43	0.94	15.5	39/64	6.35	1/4	0.20	7.0
US-LT40A(B)-21	4	No.8	1.00-1.70	6.2-15.0	2100	209	8 15/64	0.65	1.43	16.5	41/64	6.35	1/4	0.30	10.5
US-LT40A(B)-15	4	No.8	1.00-2.20	6.2-19.4	1500	209	8 15/64	0.65	1.43	16.5	41/64	6.35	1/4	0.30	10.5
US-LT40A(B)-08	5	No.10	1.60-4.00	14.1-35.2	800	209	8 15/64	0.65	1.43	16.5	41/64	6.35	1/4	0.30	10.5
US-LT50B-17	4-5	No.8-No.10	1.50-2.60	9.7-23.0	1700	240	9 29/64	1.00	2.20	19.5	49/64	9.50	3/8	0.50	17.5
US-LT50B-08	5-6	No.10-1/4	3.00-5.50	26.4-48.4	800	240	9 29/64	1.00	2.20	19.5	49/64	9.50	3/8	0.50	17.5
US-LT50B-05	5-6	No.10-1/4	5.00-10.5	44.0-92.4	480	240	9 29/64	1.00	2.20	19.5	49/64	9.50	3/8	0.50	17.5
US-LT30A(B)L-23	3	No.5	0.40-1.00	3.52-8.8	2300	229	8 15/64	0.53	1.16	15.0	19/32	6.35	1/4	0.20	5.2
US-LT30A(B)L-17	3.5	No.6	0.70-1.50	6.2-13.2	1700	229	8 15/64	0.53	1.16	15.0	19/32	6.35	1/4	0.20	5.2
US-LT30A(B)L-11	4	No.6	1.10-2.10	9.7-18.5	1100	229	8 15/64	0.53	1.16	15.0	19/32	6.35	1/4	0.20	5.2
US-LT40BL-21	4	No.8	1.00-1.70	8.8-15.0	2100	249	9 25/32	0.70	1.54	17.0	21/32	6.35	1/4	0.30	5.6
US-LT40A(B)L-15	4	No.8	1.00-2.20	8.8-19.4	1500	249	9 25/32	0.70	1.54	17.0	21/32	6.35	1/4	0.30	5.6
US-LT40BL-08	5	No.10	1.60-4.00	14.1-35.2	800	249	9 25/32	0.70	1.54	17.0	21/32	6.35	1/4	0.30	5.6

Air Inlet Size : NPT1/8" for US-LT10/20 series
 NPT1/4" for US-LT30/40/50 series
 Hex. Size of Bit : 5mm (13/64") for A-Type
 6.35mm (1/4") for B-Type

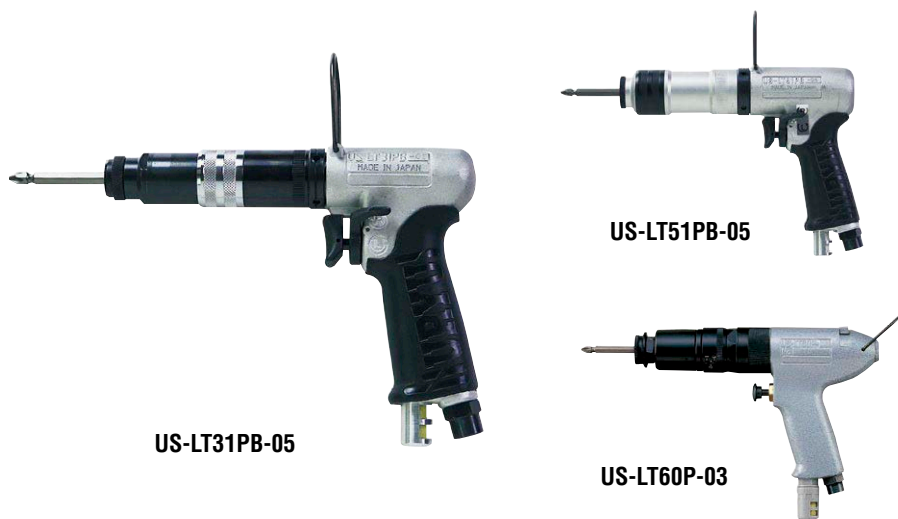

US-LT60P(P) Series

Optional 9.5mm (3/8") Sq. Drive Anvil is alternatively available. Suffix each model name with (P) as US-LT60P-03(P) or -07(P) when ordering.



Torque reaction bar should be attached for solid support to absorb the reaction when the tool comes to stall.

SPECIFICATIONS

Recommended Air Pressure : 0.5MPa (72psi)

Model	Capacity (Screw Size)		Torque Range		Free Speed (Approx.) rpm	Overall Length (about)		Weight less Bit (about)		From Center to Outside (about)		Air Hose Size (inside Dia.)		Average Air Consumption	
	mm	in	Nm	in-lbs		mm	in	kg	lb	mm	in	mm	in	m ³ /min	ft ³ /min
US-LT31PB-23	2.6	No.3	0.40-1.00	3.5-8.8	2300	170	7 1/64	0.71	1.56	16.0	39/64	6.35	1/4	0.20	7.0
US-LT31PB-17	2.2	No.2	0.70-1.50	6.2-13.2	1700	170	7 1/64	0.71	1.56	16.0	39/64	6.35	1/4	0.20	7.0
US-LT31PB-11	2.6	No.3	1.10-2.10	9.7-18.5	1100	170	7 1/64	0.71	1.56	16.0	39/64	6.35	1/4	0.20	7.0
US-LT31PB-05	3	No.5	2.40-5.00	21.1-44.0	500	189	8 3/16	0.85	1.87	16.0	39/64	6.35	1/4	0.20	7.0
US-LT41PB-21	3	No.5	1.00-1.70	8.8-15.0	2500	175	7 23/32	0.87	1.91	17.0	41/64	6.35	1/4	0.30	10.5
US-LT41PB-15	3.5	No.6	1.00-2.20	8.8-19.4	1500	175	7 23/32	0.87	1.91	17.0	41/64	6.35	1/4	0.30	10.5
US-LT41PB-08	4	No.8	1.60-4.00	14.1-35.2	800	175	7 23/32	0.87	1.91	17.0	41/64	6.35	1/4	0.30	10.5
US-LT51PB-17	4	No.8	1.50-2.60	13.2-22.9	1700	198	8 35/64	1.20	2.64	20.0	49/64	9.50	3/8	0.50	17.5
US-LT51PB-08	4	No.8	3.00-5.50	26.4-48.4	800	198	8 35/64	1.20	2.64	20.0	49/64	9.50	3/8	0.50	17.5
US-LT51PB-05	5	No.10	5.00-10.5	44.0-92.4	480	198	8 35/64	1.20	2.64	20.0	49/64	9.50	3/8	0.50	17.5
US-LT60P-11	4-5	No.8-No.10	4.00-7.00	35.2-61.6	1100	230	9 1/16	1.70	3.74	22.0	57/64	9.50	3/8	0.60	21.0
US-LT60P-07	5-6	No.10-1/4	4.00-10.0	35.2-88.0	650	230	9 1/16	1.70	3.74	22.0	57/64	9.50	3/8	0.60	21.0
US-LT60P-03	5-6	No.10-1/4	7.00-20.0	61.6-176	320	230	9 1/16	1.70	3.74	22.0	57/64	9.50	3/8	0.60	21.0

Air Inlet Size : NPT1/4" Hex. Size of Bit : 6.35mm (1/4")



US-LT40B-05C



US-LT40-03C (P)

SPECIFICATIONS

Recommended Air Pressure : 0.5MPa (72psi)

Model	Capacity (Screw Size)		Torque Range		Free Speed (Approx.) rpm	Overall Length (about)		Weight less Bit (about)		From Center to Outside (about)		Air Hose Size (inside Dia.)		Average Air Consumption	
	mm	in	Nm	in-lbs		mm	in	kg	lb	mm	in	mm	in	m ³ /min	ft ³ /min
US-LT30B-17C	2.6	No.3	0.70-1.50	6.2-13.2	1700	295	10 3/4	0.70	1.54	36.0	1 27/64	6.35	1/4	0.20	7.0
US-LT30B-11C	2.2	No.2	1.10-2.10	9.7-18.5	1100	295	10 3/4	0.70	1.54	36.0	1 27/64	6.35	1/4	0.20	7.0
US-LT40B-15C	2.6	No.3	1.00-2.20	8.8-19.4	1500	314	12 25/32	0.90	1.98	36.0	1 27/64	6.35	1/4	0.30	10.5
US-LT40B-08C	3	No.5	1.60-4.00	14.1-35.2	800	314	12 25/32	0.90	1.98	36.0	1 27/64	6.35	1/4	0.30	10.5
US-LT40B-05C	3	No.5	2.30-5.70	20.2-50.2	500	325	13 7/32	0.95	2.09	38.5	1 33/64	6.35	1/4	0.30	10.5
US-LT40-08C(P)	3.5	No.6	1.60-4.00	14.1-35.2	800	314	12 25/32	0.90	1.98	32.0	1 17/64	6.35	1/4	0.30	10.5
US-LT40-05C(P)	4	No.8	2.30-5.70	20.2-50.2	500	325	13 7/32	0.95	2.09	35.5	1 25/64	6.35	1/4	0.30	10.5
US-LT40-03C(P)	4	No.8	5.00-10.0	44-88	300	359	14 11/64	1.10	2.42	35.5	1 25/64	6.35	1/4	0.30	10.5

Air Inlet Size : NPT1/4" Hex. Size of Bit : 6.35mm (1/4") for B-Type Sq Size of Anvil : 6.35mm (1/4") for US-LT40 Series

OPTION

US-LT20-40 Series Optional Parts



Silencer Assembly

Detachable Silencer Assembly to minimize noise can be attached for more comfortable working environment.

- US-LT20 Series 455-088-2
- US-LT30 Series 408-088-2
- US-LT40 Series 496-088-1



Handle Jacket

Rubber Handle Jacket is available as an optional accessory for operator's comfort.

- US-LT20 470-083-9
- US-LT30 471-083-7
- US-LT40 496-083-0

CUSHION CLUTCH TYPE SCREWDRIVERS



US-4



US-5PB



US-40

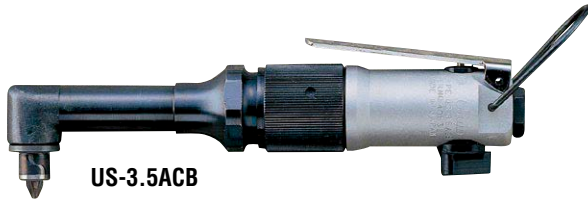

US-3.5ACB



US-5CA

FEATURES

The output torque can be adjusted by turning the adjusting nut to control spring compression or by changing the suitable spring.

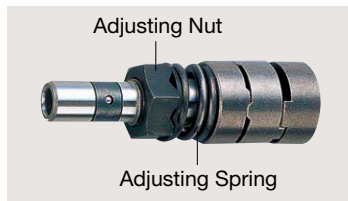

Cutaway view of Magnet type head for US-3.5MA

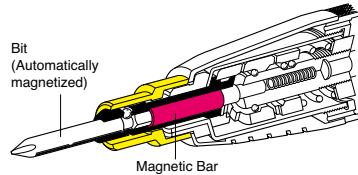

The standard bit contacts the built-in Magnetic Bar to be magnetized and holds the screw.

Head Sizes

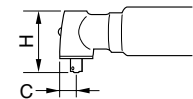

Model	C		H	
	mm	in	mm	in
US-3.5ACB	10.0	25/64	36.5	1 33/64
US-4CA	12.0	15/32	45.0	1 25/32
US-5CA	12.0	15/32	45.0	1 25/32

SPECIFICATIONS

Recommended Air Pressure : 0.4MPa (57psi)

Model	Capacity (Screw Size)		Free Speed (Approx.) rpm	Overall Length (about)		Weight less Socket or Bit (about)		From Center to Outside (about)		Hex. Size of Bit		Air Hose Size		Average Air Consumption	
	mm	in		mm	in	kg	lb	mm	in	mm	in	mm	in	m ³ /min	ft ³ /min
US-3.5A	4	No.8	2000	196	7 31/64	0.60	1.39	17.0	43/64	5.00	13/64	6.35	1/4	0.20	7.0
US-3.5B	4	No.8	2000	214	8 27/54	0.63	1.39	17.0	43/64	6.35	1/4	6.35	1/4	0.20	7.0
US-4	4	No.8	1400	236	7 3/32	0.95	2.09	20.0	25/32	5.00	13/64	6.35	1/4	0.20	7.0
US-5	5	No.10	1400	236	7 3/32	1.10	2.42	21.0	53/64	6.35	1/4	6.35	1/4	0.20	7.0

Air Inlet Size : NPT1/4"

SPECIFICATIONS

Recommended Air Pressure : 0.4MPa (57psi)

Model	Capacity (Screw Size)		Free Speed (Approx.) rpm	Overall Length (about)		Weight less Socket or Bit (about)		From Center to Outside (about)		Hex. Size of Bit		Air Hose Size		Average Air Consumption	
	mm	in		mm	in	kg	lb	mm	in	mm	in	mm	in	m ³ /min	ft ³ /min
US-3.5MA	4	No.8	2000	198	7 3/32	0.65	0.68	17.0	43/64	6.35	1/4	6.35	1/4	0.20	7.0

Air Inlet Size : NPT1/4"

SPECIFICATIONS

Recommended Air Pressure : 0.4MPa (57psi)

Model	Capacity (Screw Size)		Free Speed (Approx.) rpm	Overall Length (about)		Weight less Socket or Bit (about)		From Center to Outside (about)		Hex. Size of Bit		Air Hose Size		Average Air Consumption	
	mm	in		mm	in	kg	lb	mm	in	mm	in	mm	in	m ³ /min	ft ³ /min
US-40	4	No.8	2200	225	8 55/64	0.56	1.23	17.0	43/64	5.00	13/64	6.35	1/4	0.20	7.0
US-50	5	No.10	1200	245	9 41/64	0.90	1.98	18.0	45/64	6.35	1/4	6.35	1/4	0.30	10.7

Air Inlet Size : NPT1/4"

SPECIFICATIONS

Recommended Air Pressure : 0.4MPa (57psi)

Model	Capacity (Screw Size)		Free Speed (Approx.) rpm	Overall Length (about)		Weight Less Bit (about)		From Center to Outside (about)		Air Inlet Size	Hex. Size of Bit		Average Air Consumption	
	mm	in		mm	in	kg	lb	mm	in		mm	in	m ³ /min	ft ³ /min
US-3.5PB	4	No.8	2000	200	7 7/8	0.75	1.65	17.0	43/64	NPT1/4	6.35	1/4	0.20	7.0
US-4PB	4	No.8	1400	223	8 25/32	1.15	2.53	20.0	49/64	NPT1/4	5.00	13/64	0.20	7.0
US-5PB	5	No.8	1400	242	9 17/32	1.30	2.86	21.0	33/64	NPT1/4	6.35	1/4	0.20	7.0
* US-3.5ACB	4	No.8	2000	200	7 7/8	0.65	1.43	10.0	25/64	NPT1/4	6.35	1/4	0.20	7.0
US-4CA	4	No.8	1400	225	8 7/8	1.10	2.24	12.0	29/64	NPT1/4	6.35	1/4	0.30	10.7
US-5CA	5	No.10	500	256	10 5/64	1.40	3.08	12.0	29/64	NPT1/4	6.35	1/4	0.30	10.7

*US-3.5ACB is not the cushion clutch type but the direct drive type. Air Hose Size (Inside Diameter) : 6.35mm (1/4")

DIRECT DRIVE SCREWDRIVERS

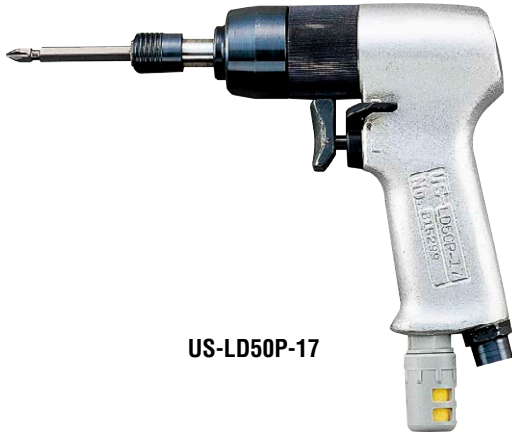

US-LD50P-17



US-LD40P-21

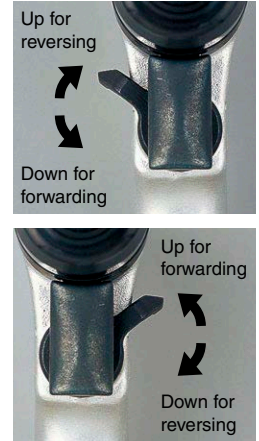

By replacing Reverse Lever, Operator can use either left or right hand.

SPECIFICATIONS

Recommended Air Pressure : 0.5MPa (72psi)

Model	Capacity (Screw Size)		Torque Range				Free Speed (about)	Overall Length (about)		Weight Less Bit (about)		From Center to Outside (about)		Average Air Consumption	
			Soft Joint		Hard Joint										
	mm	in	Nm	ft-lbs	Nm	ft-lbs	rpm	mm	in	kg	lb	mm	in	m ³ /min	ft ³ /min
US-LD40P-21	4	No.8	2.0	1.5	2.8	2.1	2500	130	5 1/14	0.7	1.54	17.0	43/64	0.40	14.0
US-LD40P-15	4	No.8	3.0	2.2	3.2	2.4	1700	130	5 1/14	0.7	1.54	17.0	43/64	0.40	14.0
US-LD40P-08	5	No.10	4.8	3.6	5.7	4.2	940	130	5 1/14	0.7	1.54	17.0	43/64	0.40	14.0
US-LD50P-17	4	No.8	3.5	2.6	5.9	4.4	1900	150	5 29/32	0.9	2.01	20.0	49/64	0.50	17.5
US-LD50P-08	5	No.10	6.5	4.8	7.8	5.8	900	153	6 1/32	0.9	2.01	20.0	49/64	0.50	17.5
US-LD50P-05	5	No.10	10.0	7.4	11.2	8.3	500	153	6 1/32	0.9	2.01	20.0	49/64	0.50	17.5

Air Inlet Size : NPT1/4" Air Hose Size : 6.35mm (1/4") Hex.Size of Bit : 6.35mm (1/4")

IMPACT SCREWDRIVERS

Small, light-weight, and high power. Operators' fatigue can be reduced thanks to discontinuous drive which has less torque reaction.



US-350W



US-450WB



US-5W



US-6W



US-45W

SPECIFICATIONS (STRAIGHT TYPE)

Model	Capacity (Screw Size)		Free Speed (Approx.) rpm	Overall Length (about)		Weight Less Bit (about)		From Center to Outside (about)		Hex. Size of Bit		Air Hose Size (inside Dia)		Average Air Consumption		Recommended Air Pressure	
	mm	in		mm	in	kg	lb	mm	in	mm	in	mm	in	m ³ /min	ft ³ /min	Mpa	psi
US-350W	4	No.8	14000	168	6 5/8	0.40	0.88	17.0	43/64	6.35	1/4	6.35	1/4	0.20	7.0	0.4	57
US-450WB	5	No.10	11000	161	6 5/16	0.55	1.21	18.5	47/64	6.35	1/4	6.35	1/4	0.20	7.0	0.4	57
US-45W	5	No.10	12000	183	7 13/64	0.50	1.10	17.0	43/64	6.35	1/4	6.35	1/4	0.20	7.0	0.4	57
US-5W	5	No.10	9500	198	7 51/64	0.80	1.60	20.0	27/32	6.35	1/4	6.35	1/4	0.20	7.0	0.4	57
US-6W	6	1/4	9500	187	7 23/64	0.80	1.76	22.5	57/64	6.35	1/4	6.35	1/4	0.30	10.5	0.4	57

Air Inlet Size : NPT1/4"



US-350PW



US-450PW



US-5PW



US-6PW



US-652PW

SPECIFICATIONS (PISTOL TYPE)

Model	Capacity (Screw Size)		Free Speed (Approx.) rpm	Overall Length (about)		Weight Less Bit (about)		From Center to Outside (about)		Hex. Size of Bit		Air Hose Size (inside Dia)		Average Air Consumption		Recommended Air Pressure	
	mm	in		mm	in	kg	lb	mm	in	mm	in	mm	in	m ³ /min	ft ³ /min	Mpa	psi
US-350PW	4	No.8	15000	121	4 49/64	0.53	1.16	17.0	43/64	6.35	1/4	6.35	1/4	0.20	7.0	0.4	57
US-450PW	5	No.10	14000	151	5 15/16	0.75	1.65	17.0	43/64	6.35	1/4	6.35	1/4	0.20	7.0	0.4	57
US-5PW	5	No.10	9500	168	6 5/8	0.95	2.10	20.0	25/32	6.35	1/4	6.35	1/4	0.30	10.5	0.4	57
US-6PW	6	1/4	9500	170	6 11/16	1.00	2.20	23.0	57/64	6.35	1/4	6.35	1/4	0.30	10.5	0.4	57
US-652PW	6	1/4	9000	155	6 7/64	0.85	1.87	23.0	15/16	6.35	1/4	6.35	1/4	0.35	12.4	0.5	72

Air Inlet Size : NPT1/4"

AIR HOSE BALANCER

The "Line Reel" air hose balancer, without any hampering chain or rope to balance the tool, contributes to keep the work bench and work area uncluttered for safer operation, higher productivity, less operator's fatigue and longer tool life.

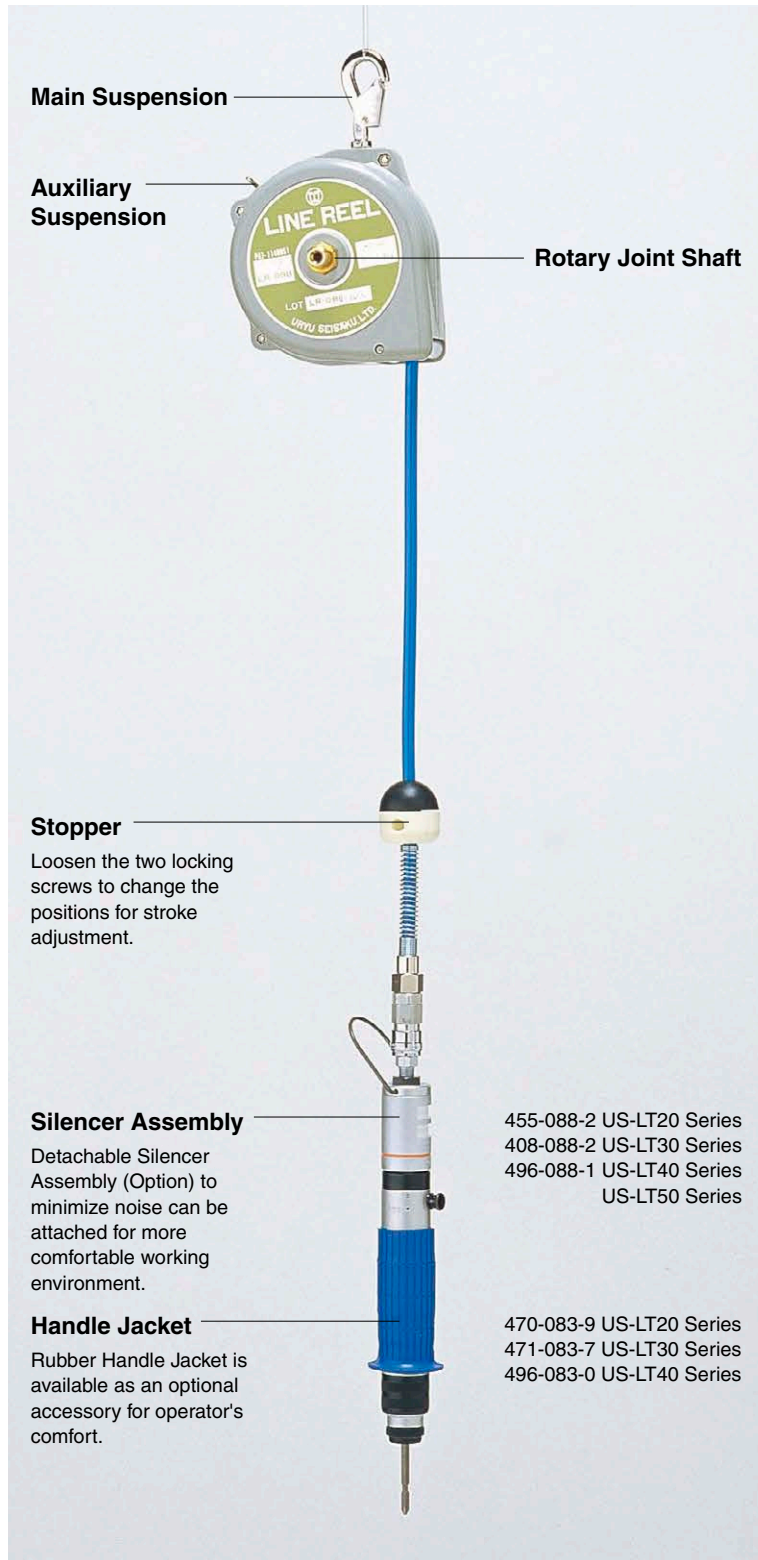

Main Suspension

Auxiliary Suspension

Rotary Joint Shaft

Stopper

Loosen the two locking screws to change the positions for stroke adjustment.

Silencer Assembly

Detachable Silencer Assembly (Option) to minimize noise can be attached for more comfortable working environment.

Handle Jacket

Rubber Handle Jacket is available as an optional accessory for operator's comfort.

455-088-2 US-LT20 Series
408-088-2 US-LT30 Series
496-088-1 US-LT40 Series
US-LT50 Series

470-083-9 US-LT20 Series
471-083-7 US-LT30 Series
496-083-0 US-LT40 Series

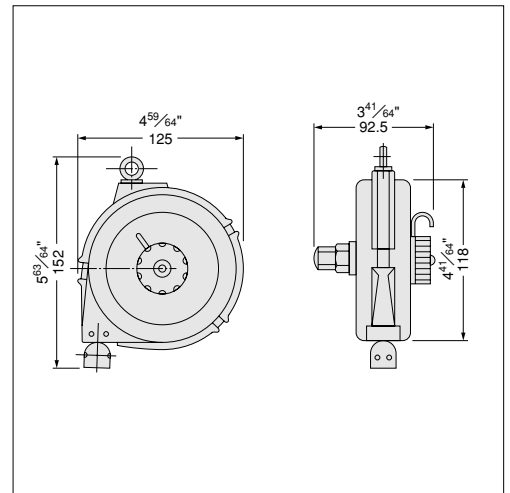

Locking Spring

Push to release the Adjustment Dial for anti-clockwise turn.

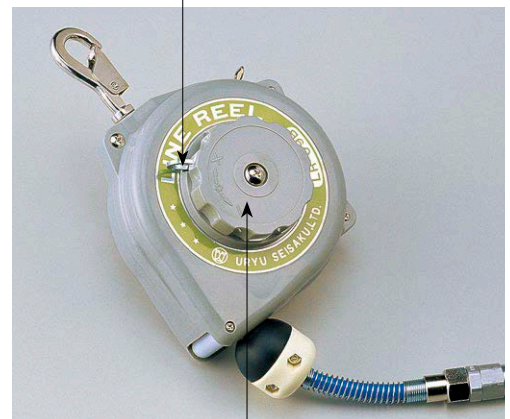

Adjustment Dial Turn

clockwise for heavier load and counter-clockwise for lighter load.

SPECIFICATIONS

Model	Max Suspending Capacity		Air Hose Size I.D. x O.D. x Length		Weight (about)		Max Stroke		Max Air Pressure	
	kg	lb	mm	in	kg	lb	mm	in	Mpa	psi
LR-09(B-90)	1.4	3.08	5 × 8.5 × 900	13/64 × 21/64 × 35 7/16	0.85	1.87	700	27 9/16	1	142
LR-09(B-200)	1.4	3.08	5 × 8.5 × 2000	13/64 × 21/64 × 78 47/64	0.9	1.98	700	27 9/16	1	142

ABRASIVE TOOLS

GRINDERS
SANDERS
POLISHERS

DIE GRINDERS

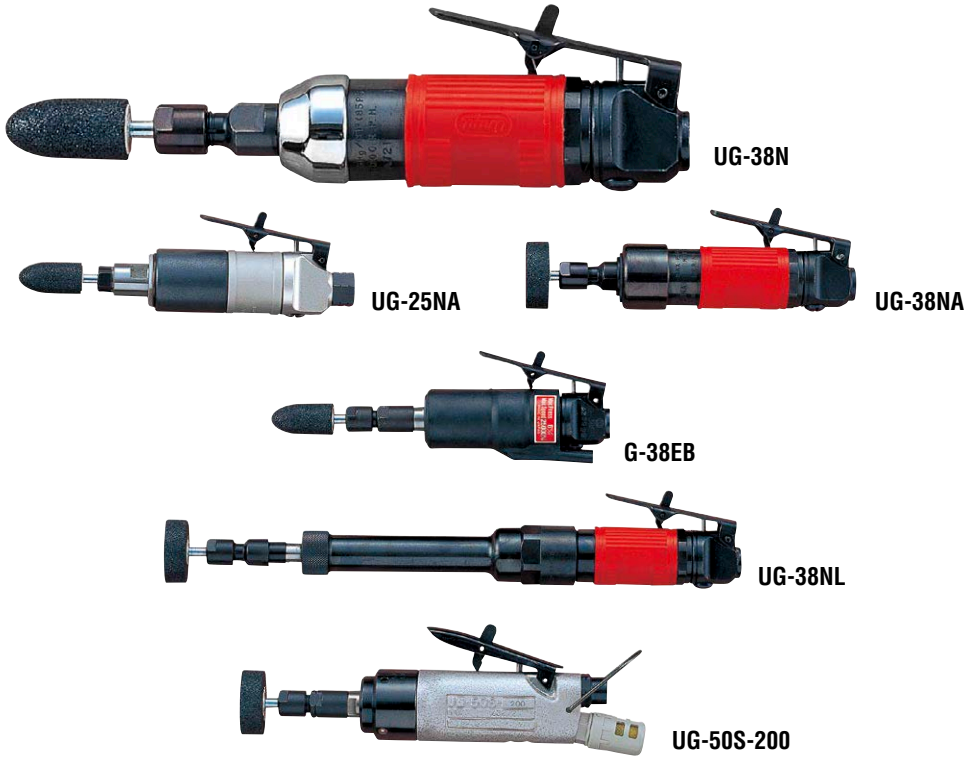

Self-Locking Lever attachment

To prevent accidental start of motor.



COLLET CHUCKS

G-38EB & UG-50S-200

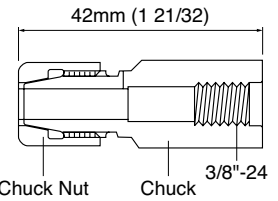

- 923-534-0 3mm
- 923-535-0 6mm
- 923-536-0 1/4"

SPECIFICATIONS

Recommended Air Pressure : 0.6MPa (85psi)

Model	Collet Chuck Size		Max.Free Speed (about)	Rated Horse Power	Overall Length (about)		Weight less wheel (about)		Air Inlet Thread (Pipe Tap)	Air Hose Size		Average Air Consumption	
	mm	in			rpm	w	mm	in		kg	lb	in	mm
UG-25NA	6	1/4	23500	210	153	6 1/32	0.53	1.17	NPT1/4	9.5	3/8	0.3	10.7
G-38EB	6	1/4	20000	315	165	6 1/2	0.65	1.43	NPT1/4	9.5	3/8	0.4	14.0
UG-38N	6	1/4	25000	315	164	6 15/32	0.57	1.25	NPT1/4	9.5	3/8	0.3	10.7
UG-38NA	6	1/4	22000	315	165	6 1/2	0.65	1.43	NPT1/4	9.5	3/8	0.4	14.0
UG-38NL	6	1/4	21000	315	316	12 7/16	0.92	2.02	NPT1/4	9.5	3/8	0.3	10.7
UG-50S-200	6	1/4	23000	195	198	7 51/64	0.60	1.32	NPT1/4	9.5	3/8	0.4	14.0

* Please never mount Grinding Wheels whose diameters are 50mm and larger.

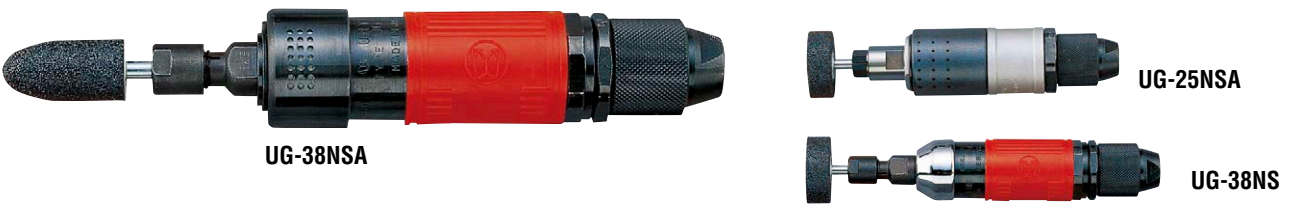

COLLET CHUCKS

UG-25N Series

30mm (1 3/16)

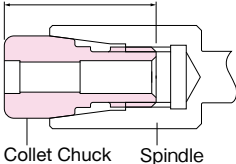

- Chuck 6mm 923-003-0
- Chuck 3mm 923-001-0

UG-38N Series Chuck Assembly (Chuck+Chuck Nut)

47mm (1 55/64)

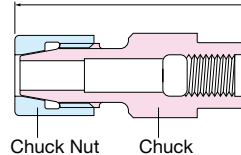

- Chuck Assembly 6mm 923-512-0
- Chuck Assembly 3mm 923-510-0

SPECIFICATIONS

Recommended Air Pressure : 0.6MPa (85psi)

Model	Collet Chuck Size		Max.Free Speed (about)	Rated Horse Power	Overall Length (about)		Weight less wheel (about)		Air Inlet Thread (Pipe Tap)	Air Hose Size		Average Air Consumption	
	mm	in			rpm	w	mm	in		kg	lb	in	mm
UG-25NSA	6	1/4	23500	210	145	5 23/32	0.56	1.23	NPT1/4	9.5	3/8	0.3	10.7
UG-38NS	6	1/4	25000	315	174	6 27/32	0.60	1.32	NPT1/4	9.5	3/8	0.3	10.7
UG-38NSA	6	1/4	22000	315	174	6 27/32	0.65	1.43	NPT1/4	9.5	3/8	0.3	10.7
UG-38NSL	6	1/4	21000	315	330	12 63/64	0.95	2.09	NPT1/4	9.5	3/8	0.3	10.7

* Please never mount Grinding Wheels whose diameters are 50mm and larger.

ABRASIVE TOOLS

DIE GRINDERS & MIDGET GRINDER

UMG-450, muffled by a rubber silencer to minimize sound level for operator's comfort, is a super speed model for precise grinding and polishing for die making.



Fasten the collet chuck firmly to avoid loosening of the cutting tool.



UG-45H

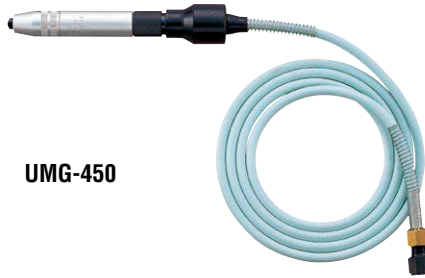

UMG-450

COLLET CHUCKS

UG-45H

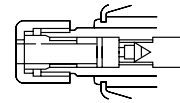

923-170-0	6mm
923-171-0	1/4"
923-172-0	8mm

SPECIFICATIONS

Recommended Air Pressure : 0.6MPa (85psi)

Model	Collet Chuck Size		Max.Free Speed (about)	Rated Horse Power	Overall Length (about)		Weight less wheel (about)		Air Inlet Thread (Pipe Tap)	Air Hose Size		Average Air Consumption	
	mm	in	rpm	w	mm	in	kg	lb	in	mm	in	m ³ /min	ft ³ /min
UMG-450	3	No.5	45000	37	145	5 45/64	0.19	0.42	NPT1/4	4.8	3/16	0.2	7.0
UG-45H	6	1/4	18000	375	196	7 23/62	0.80	1.76	NPT1/4	9.5	3/8	0.6	22.0

* Please never mount Grinding Wheels whose diameters are 50mm and larger.

MINI ANGLE GRINDERS

UG-20A series are specially designed for applications of hard-to-reach areas.



UG-20A-200



UG-50S-200A

ERICKSON Type COLLET CHUCKS

UG-20A Series	923-207-0	6mm
	923-201-0	1/4"

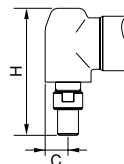
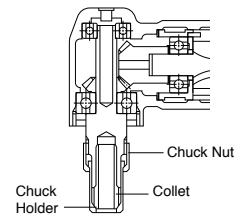

Model	C		H	
	mm	in	mm	in
UG-20A-120	14.5	37/64	80.0	3 5/32
UG-20A-200	14.5	37/64	80.0	3 5/32
UG-50S-200A	19.5	49/64	87.0	3 27/64

SPECIFICATIONS

Recommended Air Pressure : 0.6MPa (85psi)

Model	Collet Chuck Size		Max.Free Speed (about)	Rated Horse Power	Overall Length (about)		Weight less wheel (about)		Air Inlet Thread (Pipe Tap)	Air Hose Size		Average Air Consumption	
	mm	in	rpm	w	mm	in	kg	lb	in	mm	in	m ³ /min	ft ³ /min
UG-20A-120	6	1/4	12000	113	131	5 3/16	0.50	1.10	NPT1/4	9.5	3/8	0.3	10.7
UG-20A-200	6	1/4	20000	113	131	5 3/16	0.50	1.10	NPT1/4	9.5	3/8	0.3	10.7
UG-50S-200A	6	1/4	20000	195	195	7 45/64	0.90	1.98	NPT1/4	9.5	3/8	0.4	14.0

* Please never mount Grinding Wheels whose diameters are 50mm and larger.

GRINDERS

LIGHT TYPE UG-65 SERIES

Available in 9 models with three different throttle handles, these lightweight and compact grinders are generally used in all metal working industries for every grinding and polishing job.



UG-65E



UG-65EL



UG-65ER



UG-65EB



UG-65EBR



UG-65EBL



UG-650E



UG-650EL



UG-650ER

Collet chucks of 6mm and 1/4" capacity are available as optional accessories for mandrel mounted abrasives, cutters and files.

	6mm	1/4"
UNF3/8-24	923-530-0	923-532-0
W3/8-16	923-523-0	923-526-0

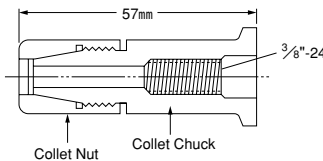

SPECIFICATIONS

Recommended Air Pressure : 0.6MPa (85psi)

Type	Model	Throttle Handle	Capacity (Wheel Size)		Max. Free Speed (about)	Rated Horse Power	Overall Length (about)		Weight less wheel (about)		Air Inlet Thread (Pipe Tap)	Air Hose Size		Average Air Consumption	
			mm	in			rpm	w	mm	in		kg	lb	in	mm
Standard	UG-65E	Sleeve	63.5	2 1/2	14600	412	242	9 27/32	1.25	2.75	NPT1/4	9.5	3/8	0.6	22
	UG-65ER	Self-closing	63.5	2 1/2	14600	412	271	10 43/64	1.50	3.30	NPT1/4	9.5	3/8	0.6	22
	UG-65EL	Lever	63.5	2 1/2	14600	412	272	10 23/32	1.40	3.08	NPT1/4	9.5	3/8	0.6	22
Rear Exhaust	UG-65EB	Sleeve	63.5	2 1/2	*14600	412	242	9 27/32	1.25	2.75	NPT1/4	9.5	3/8	0.6	22
	UG-65EBR	Self-closing	63.5	2 1/2	*14600	412	271	10 43/64	1.50	3.30	NPT1/4	9.5	3/8	0.6	22
	UG-65EBL	Lever	63.5	2 1/2	*14600	412	272	10 23/32	1.40	3.08	NPT1/4	9.5	3/8	0.6	22
Extended	UG-650E	Sleeve	63.5	2 1/2	14600	412	390	15 23/64	1.72	3.78	NPT1/4	9.5	3/8	0.6	22
	UG-650ER	Self-closing	63.5	2 1/2	14600	412	419	16 1/2	1.97	4.33	NPT1/4	9.5	3/8	0.6	22
	UG-650EL	Lever	63.5	2 1/2	14600	412	420	16 17/32	1.55	3.41	NPT1/4	9.5	3/8	0.6	22

* Speed without silencer

GRINDERS



USG-7S



USG-L180D



USG-4S



AG-50L



AG-100SL



AG-100S

"OUT" type

3/8"-24 Spindle with large FLANGE

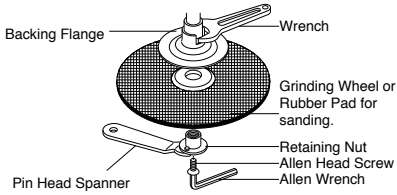

"IN" type

URYU special Spindle with small FLANGE

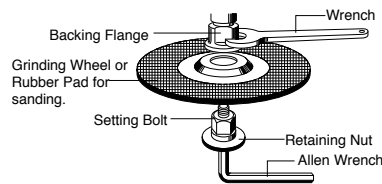

WHEEL SIZE

Model	Thickness	Height
AG-50 Series	3-5mm	9mm
AG-100 Series	4-6mm	10mm
USG-4S	4-6mm	10mm
USG-7S	6-8mm	13mm
USG-L180D	6-8mm	13mm

SPECIFICATIONS

Recommended Air Pressure : 0.6MPa (85psi)

Model	Capacity (Wheel size)		Max.Free Speed (about)	Rated Horse Power	Overall Length (about)		Overall Height (about)		Weight less wheel (about)		Type of Spindle	Air Inlet Thread (Pipe Tap)	Air Hose Size		Average Air Consumption	
	mm	in			rpm	w	mm	in	mm	in			kg	lb	in	mm
AG-50(OUT)	50	2	15000	337	147	5 25/32	54	2 1/2	0.63	1.40	OUT	NPT1/4	9.5	3/8	0.45	16.0
AG-50L(OUT)	50	2	15000	337	140	5 34/64	54	2 1/2	0.63	1.40	OUT	NPT1/4	9.5	3/8	0.45	16.0
AG-100(IN)	100	4	13500	315	175	6 57/64	68	2 43/64	0.95	2.10	IN	NPT1/4	9.5	3/8	0.50	18.0
AG-100L(IN)	100	4	13500	315	179	7 3/64	68	2 43/64	1.05	2.30	IN	NPT1/4	9.5	3/8	0.50	18.0
AG-100(OUT)	100	4	13500	315	175	6 57/64	68	2 43/64	0.95	2.10	OUT	NPT1/4	9.5	3/8	0.50	18.0
AG-100L(OUT)	100	4	13500	315	179	7 3/64	68	2 43/64	1.05	2.30	OUT	NPT1/4	9.5	3/8	0.50	18.0
AG-100S(IN)	100	4	13500	315	175	6 57/64	68	2 43/64	1.00	2.20	IN	NPT1/4	9.5	3/8	0.50	18.0
AG-100SL(IN)	100	4	13500	315	179	7 3/64	68	2 43/64	1.10	2.40	IN	NPT1/4	9.5	3/8	0.50	18.0
AG-100S(OUT)	100	4	13500	315	179	7 3/64	68	2 43/64	1.00	2.20	OUT	NPT1/4	9.5	3/8	0.50	18.0
AG-100SL(OUT)	100	4	13500	315	179	7 3/64	68	2 43/64	1.10	2.40	OUT	NPT1/4	9.5	3/8	0.50	18.0
USG-4S	100	4	13500	450	236	9 19/64	94	3 45/64	1.65	3.60	IN	NPT1/4	9.5	3/8	0.60	22.0
USG-7S	180	7	7600	962	296	11 21/32	120	4 47/54	3.00	6.60	IN	NPT3/8	12.7	1/2	1.30	46.0
USG-L180D	180	7	7600	888	267	9 1/2	92	3 5/8	2.70	5.90	IN	NPT3/8	12.7	1/2	1.00	36.0

VERTICAL GRINDERS



UVG-2300SL-59



UVG-1800SL-84



USG-4VL



USG-5VLA

100mm(4") & 125mm(5") Type

USG series * These gear-less vertical grinders of simple non-governed design offer powerful and trouble free operation.

180mm(7") & 230mm(9") Type

UVG series * Non-friction speed control governor incorporated with over-speed sensing device. This special governor contributes to power compensation also especially when grinding resistance gets strong causing slow speed.
 * Three different speeds are available for UVG-1800.
 * UVG-2300 series is equipped with Dual and Consecutive action Speed Piston Valve for smooth valve opening.

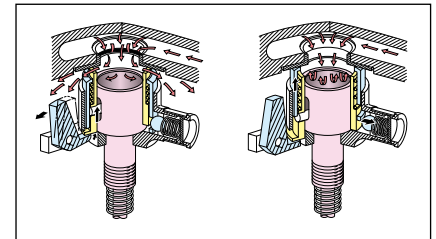

UVG SERIES

NON-FRICTION SPEED CONTROL GOVERNOR incorporated in OVERSPEED SENSING DEVICE

SPECIFICATIONS

Recommended Air Pressure : 0.6MPa (85psi)

Model	Capacity (Wheel size)		Max.Free Speed (about)	Rated Horse Power	Overall Length (about)		Overall Height (about)		Weight less wheel (about)		Type of Spindle	Air Inlet Thread (Pipe Tap)	Air Hose Size		Average Air Consumption	
	mm	in			rpm	w	mm	in	mm	in			kg	lb	in	mm
USG-4VL	100	4	12000	435	220	8 21/32	97	3 13/16	1.40	3.09	IN	NPT1/4	9.5	3/8	0.85	30.0
USG-5VLA	125	5	10500	375	220	8 21/32	97	3 13/16	1.48	3.26	IN	NPT1/4	9.5	3/8	0.85	30.0
UVG-1500SL-76	180	7	7600	1200	-	-	162	6 3/8	3.30	7.26	OUT	NPT3/8	12.7	1/2	1.40	49.0
UVG-1500SL-84	180	7	8400	1200	-	-	162	6 3/8	3.30	7.26	OUT	NPT3/8	12.7	1/2	1.40	49.0
UVG-1800SL-76	180	7	7600	1650	-	-	175	6 7/8	4.00	8.80	OUT	NPT3/8	12.7	1/2	2.00	70.0
UVG-1800SL-84	180	7	8400	1650	-	-	175	6 7/8	4.00	8.80	OUT	NPT3/8	12.7	1/2	2.00	70.0
UVG-2300SL-59	230	9	5900	2550	-	-	182	7 5/32	4.80	10.56	OUT	NPT1/2	19.0	3/4	2.50	80.0

ANGLE GRINDERS



UAG-50SBL-120

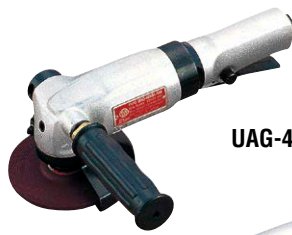

UAG-40SBL-136



UAG-70SBL-76



UAG-90SBL-59

LOCK BUTTON

Push the spring-loaded Lock Button to release the Throttle Lever for operation. When released the Lever is locked automatically.

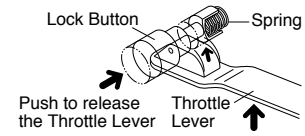

ROLL TYPE THROTTLE HANDLE



UAG-○○SB series
UAG-○○SC series

100mm-230mm(4"-9") Wheel Dia.

URYU offers UAG-series Angle Grinders of 100mm(4"), 125mm(5"), 180mm(7") and 230mm(9") capacity. These governed lightweight and compact grinders deliver high power to weight ratio and feature.

- Non-friction Speed Governor for most efficient grinding performance.
- Unique spring-loaded Exhaust Valve for noise-less trouble free operation.
- Vibration absorbent Dead Handle for less Operator fatigue.

"B" type

Spindle with large Flange

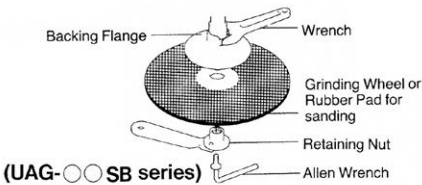

"C" type

URYU unique Spindle with small Flange

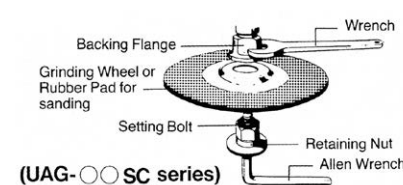

Spring-loaded EXHAUST VALVE

This exhaust hole is kept closed off-operation but is opened upon triggering. This unique exhaust valve features:

- Cutting exhaust noise especially when air is shut off.
- Preventing foreign matters inhalation into the tool.



SPECIFICATIONS

Recommended Air Pressure : 0.6MPa (85psi)

Model	Capacity (Wheel size)		Max.Free Speed (about)	Rated Horse Power	Overall Length (about)		Overall Height (about)		Weight less wheel (about)		Type of Spindle	Air Inlet Thread (Pipe Tap)	Air Hose Size		Average Air Consumption	
	mm	in			mm	in	mm	in	kg	lb			mm	in	m ³ /min	ft ³ /min
UAG-40SB-136	100	4	13600	712	208	8 3/16	76	3	1.5	3.3	OUT	NPT1/4	9.5	3/8	0.95	34.0
UAG-40SBL-136	100	4	13600	712	246	9 11/16	76	3	1.3	2.9	OUT	NPT1/4	9.5	3/8	0.95	34.0
UAG-40SC-136	100	4	13600	712	208	8 3/16	76	3	1.5	3.3	IN	NPT1/4	9.5	3/8	0.95	34.0
UAG-40SCL-136	100	4	13600	712	246	9 11/16	76	3	1.3	2.9	IN	NPT1/4	9.5	3/8	0.95	34.0
UAG-50SBL-120	125	5	12000	712	246	9 11/16	76	3	1.4	3.1	OUT	NPT1/4	9.5	3/8	0.95	34.0
UAG-50SCL-120	125	5	12000	712	246	9 11/16	76	3	1.4	3.1	IN	NPT1/4	9.5	3/8	0.95	34.0
UAG-50SC-120	125	5	12000	712	208	8 3/16	76	3	1.6	3.5	IN	NPT1/4	9.5	3/8	0.95	34.0
UAG-50SB-109	125	5	10900	712	208	8 3/16	76	3	1.6	3.5	OUT	NPT1/4	9.5	3/8	0.95	34.0
UAG-50SBL-109	125	5	10900	712	246	9 11/16	76	3	1.4	3.1	OUT	NPT1/4	9.5	3/8	0.95	34.0
UAG-70SBL-76	180	7	7600	1500	300	11 13/16	98	3 55/64	2.9	6.4	OUT	NPT3/8	12.7	1/2	1.60	57.0
UAG-70SB-76	180	7	7600	1500	253	10	98	3 55/64	3.0	6.6	OUT	NPT3/8	12.7	1/2	1.60	57.0
UAG-70SC-76	180	7	7600	1500	253	10	87	3 27/64	3.0	6.6	IN	NPT3/8	12.7	1/2	1.60	57.0
UAG-70SCL-76	180	7	7600	1500	300	11 13/16	87	3 27/64	2.8	6.2	IN	NPT3/8	12.7	1/2	1.60	57.0
UAG-90SBL-59	230	9	5900	1875	308	12 1/8	98	3 55/64	3.3	7.3	OUT	NPT3/8	12.7	1/2	1.90	67.0

HORIZONTAL GRINDERS



UG-1250L-72



UG-1250-72



UG-1500L-60



UG-1500-60

Heavy-Duty Type (Governed)

- Two speeds are available for UG-1500 series.
(Higher speed for resinoid wheels and lower speed for vitrified wheels)
- Two different Throttle Handles are available for every model.
- Lever Type Handles are recommended for safer operation.

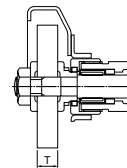

WHEEL SIZE

Model Name	Thickness
UG-1250 Series	13-19mm
UG-1500 Series	18-25mm

SPECIFICATIONS

Recommended Air Pressure : 0.6MPa (85psi)

Model	Capacity (Wheel Size)		Max.Free Speed (about)	Rated Horse Power	Overall Length (about)		Weight less wheel (about)		Spindle Size	Air Inlet Thread (Pipe Tap)	Air Hose Size		Average Air Consumption	
	mm	in			rpm	w	mm	in			kg	lb	in	in
UG-1250-72	125	5	7200	750	436	17 11/64	3.20	7.04	1/2-13	NPT3/8	12.7	1/2	0.90	32.7
UG-1250L-72	125	5	7200	750	436	17 11/64	2.80	6.16	1/2-13	NPT3/8	12.7	1/2	0.90	32.7
UG-1500-60	150	6	6000	1320	497	19 9/16	4.88	10.74	5/8-11	NPT3/8	12.7	1/2	1.30	45.9
UG-1500-41	150	6	4100	975	497	19 9/16	4.88	10.74	5/8-11	NPT3/8	12.7	1/2	1.30	45.9
UG-1500L-60	150	6	6000	1320	495	19 31/64	4.62	10.16	5/8-11	NPT3/8	12.7	1/2	1.30	45.9
UG-1500L-41	150	6	4100	975	495	19 31/64	4.62	10.16	5/8-11	NPT3/8	12.7	1/2	1.30	45.9

* Do not use vitrified wheels with higher speed type of each model.

SANDERS / POLISHERS



UP-25DB



UP-15



UP-15N



USG-45P



UP-25NB

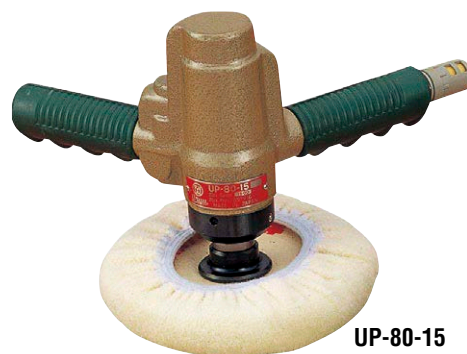

UP-80-15

UP-15N/25NB PAD

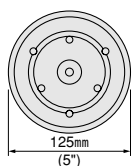

UP-26NB PAD

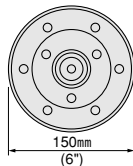

HOLED PAD



Dust collection bag
For UP-15N, 25NB&26NB

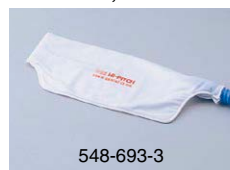

SPECIFICATIONS

Recommended Air Pressure : 0.6MPa (85psi)

Model	Capacity (Pad/Paper size)		Max.Free Speed (about)	Rated Horse Power	Overall Length (about)		Overall Height (about)		Weight less wheel (about)		Spindle Size	Air Inlet Thread (Pipe Tap)	Air Hose Size		Average Air Consumption	
	mm	in			rpm	w	mm	in	mm	in			kg	lb	in	in
USG-45P	125	5	12000	225	187	7 23/64	104	4 3/32	0.87	1.91	3/8-24	NPT1/4	9.5	3/8	0.55	20.0
UP-80-15	160	6 3/8	1500	337	-	-	170	6 7/8	1.80	3.96	5/8-11	NPT1/4	9.5	3/8	0.80	28.0
UP-80-40	160	6 3/8	4000	337	-	-	164	6 15/32	1.80	3.96	5/8-11	NPT1/4	9.5	3/8	0.80	28.0
UP-80-60	160	5/16	6000	337	-	-	170	6 7/8	1.80	3.96	5/8-11	NPT1/4	9.5	3/8	0.80	28.0
UP-15	125	5	8500	210	112	4 13/32	93	3 21/32	1.20	2.64	-	NPT1/4	6.35	1/4	0.45	16.0
UP-25DB	125	5	11000	259	212	8 11/32	120	4 3/4	1.70	3.74	-	NPT1/4	6.35	1/4	0.20	7.0
UP-26DB	150	6	11000	259	212	8 11/32	120	4 3/4	1.78	3.92	-	NPT1/4	6.35	1/4	0.20	7.0
UP-15N	125	5	9000	225	175	6 57/64	103	4 1/16	1.50	3.30	-	NPT1/4	6.35	1/4	0.45	16.0
UP-25NB	125	5	9000	300	250	9 23/64	119	4 23/32	1.77	3.90	-	NPT1/4	9.5	3/8	0.60	21.0
UP-26NB	150	6	9000	300	263	10 23/64	119	4 23/32	1.95	4.30	-	NPT1/4	9.5	3/8	0.60	21.0

FEATURES

Features of Dual Action Orbital Sander UP-15, UP-25DB/26DB, UP-25NB/26NB

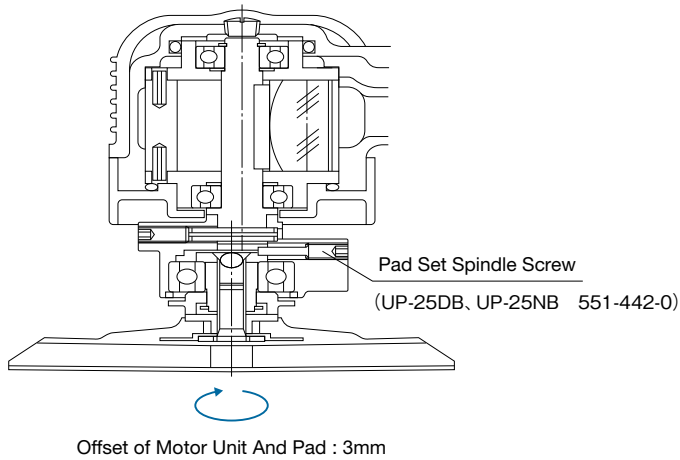

Dual action type (Dual rotation movement) adopted. As the whole surface of paper attached rubber pad is rotated in ellipse and true circle, smooth finish without sanding scratch is possible.

Movement of Single Point on Rubber Pad

(Without Pad Set Spindle Screw)

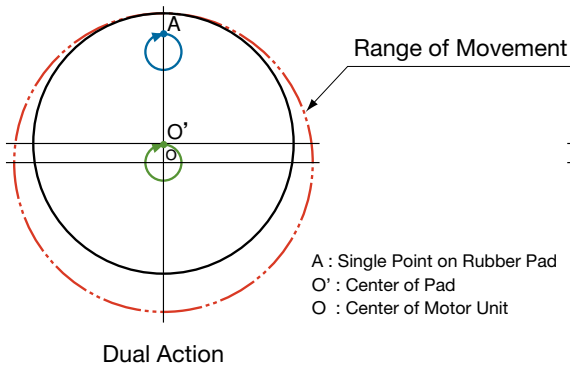

(With Pad Set Spindle Screw)

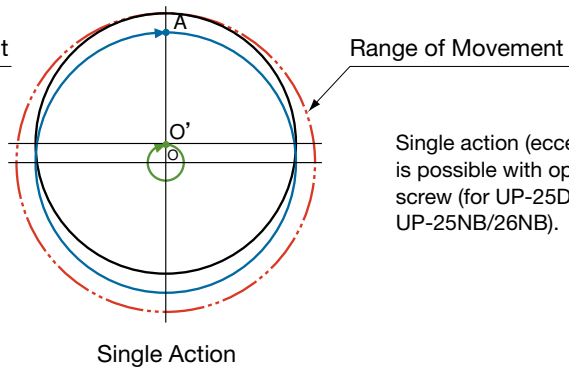

Single action (eccentric movement only) is possible with optional pad set spindle screw (for UP-25DB/26DB, UP-25NB/26NB).

Self-Suction Type Dual Action Orbital Sander (UP-25NB/26NB)

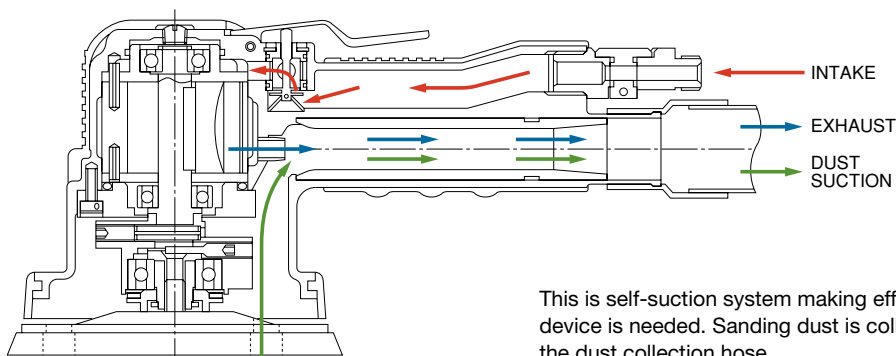

This is self-suction system making effective use of exhaust. No forced suction device is needed. Sanding dust is collected in the dust collection bag, through the dust collection hose.

Backing Pad Assembly for UP-25/UP-26 Series

Name	Dimension					Part Number	Model
	A (mm)	B (mm)	C (mm)	D (mm)	E		
Backing Pad Assembly (5")	124	31.5	20.5	11	NPT1/4	551-409-2	UP-25DB
Backing Pad Assembly (6")	149	30	19	11	NPT1/4	551-409-8	UP-26DB
Backing Pad Assembly (5")	124	28	16.5	11.5	NPT1/4	548-409-3	UP-25NB
Backing Pad Assembly (6")	149	30	19	11	NPT1/4	548-409-5	UP-26NB

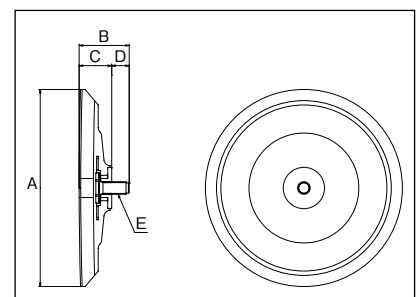

WARNING FOR SAFETY USE

Firstly, follow your local safety regulations strictly on grinders and abrasives. Following are basically required.

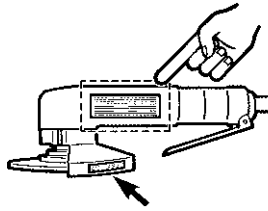

1. Before mounting to the Grinder, make sure that the Grinding Wheels or other Abrasives are of suitable size, shape, quality and strength to the rated speed (RPM) stamped on the name plate or tool housing.

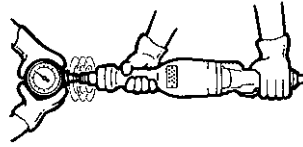

2. The Wheel Spindle speed should be regularly checked with a tachometer to make sure whether normal speed is maintained. The governed Grinders must be checked to be sure governor mechanism is functioning properly.

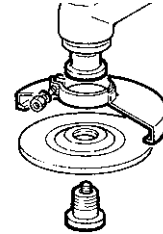

3. Make sure before operation that the Abrasive Wheel should be mounted carefully and sufficiently with flanges and nuts of proper size and shape by use of the Spanners.

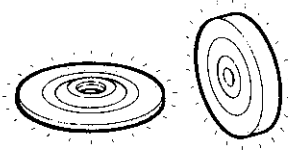

4. All Grinding Wheels should be closely inspected before installation and use. If cracks, nicks, or chips are found, do not use the Wheel in question.

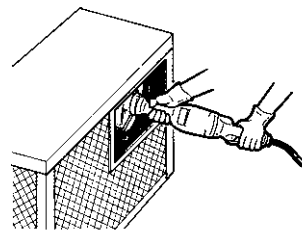

5. Before installing a Grinding Wheel, after all Grinders repair and whenever the Grinder is issued for use, test run the Grinder by a competent person for one minute under a protected area.

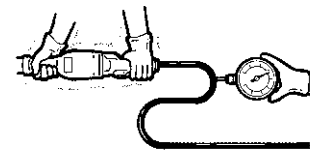

6. Pay attention so that the speed of Grinder does not exceed its maximum speed specified. Do not increase air pressure for power-up.

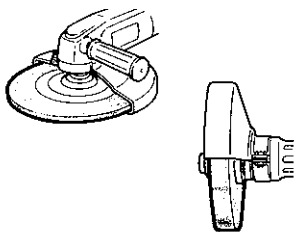

7. Make sure to use wheel guard of suitable size and fix it properly when using Grinding Wheels of more than 50mm in diameter.

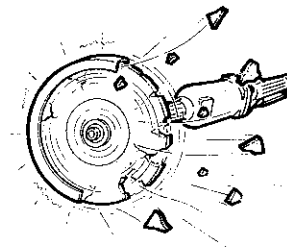

8. Never exceed maximum speed of the Abrasive Wheel to avoid dangerous breakage. Fragments from the Wheel can cause serious injury or death. Do not operate without wearing eye protector and gloves.

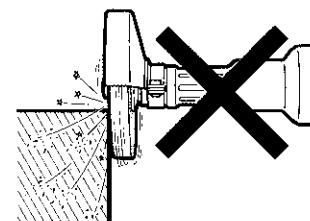

9. Never use the side of grinding Wheel, when a Grinding Wheel is not intentionally designed for side use.

DRILLS & TAPPERS

COMBINATION DRILLS
TAPPERS



DRILLS



UD-50-45

Power is controlled by the built-in Air Regulator located on the handle.
(Pistol handle type only)



UD-50-22



UD-60-29



UD-60-04



UD-80-12

SPECIFICATIONS

Recommended Air Pressure : 0.6MPa (85psi)

Model	Drilling Capacity		Free Speed (about)	Overall Length (about)		Weight with Chuck (about)		From Center to Outside (about)		Nominal Chuck Size		Type of Spindle	Average Air Consumption	
	mm	in	rpm	mm	in	kg	lb	mm	in	mm	in	in-thr'd	m ³ /min	ft ³ /min
UD-50-200	3	No.5	23000	135	5 5/16	0.70	1.50	21.0	53/64	8	5/16	3/8-24UNF	0.40	14
UD-50-45	6	1/4	5000	145	5 23/32	0.86	1.89	21.0	53/64	8	5/16	3/8-24UNF	0.40	14
UD-50-22	8	5/16	2200	140	5 1/2	0.90	1.98	21.0	53/64	8	5/16	3/8-24UNF	0.40	14
UD-60-29	8	5/16	2900	165	6 1/2	1.10	2.43	22.5	57/64	8	5/16	3/8-24UNF	0.50	18
UD-60-20	8	5/16	2000	180	7 1/8	1.20	2.64	22.5	57/64	8	5/16	3/8-24UNF	0.50	18
UD-60-15	8	5/16	1600	180	7 1/8	1.20	2.64	22.5	57/64	8	5/16	3/8-24UNF	0.50	18
UD-60-07	13	1/2	700	219	8 5/8	1.40	3.08	22.5	57/64	13	1/2	1/2-20UNF	0.50	18
UD-60-04	13	1/2	500	220	8 5/8	1.40	3.08	22.5	57/64	13	1/2	1/2-20UNF	0.50	18
UD-80-12	13	1/2	1200	216	8 1/2	1.80	3.96	26.0	1 1/64	13	1/2	1/2-20UNF	0.65	23
UD-80-07	13	1/2	700	239	9 13/32	2.30	5.06	26.0	1 1/64	13	1/2	1/2-20UNF	0.65	23
UD-80-04	16	5/8	400	247	9 23/32	2.90	6.39	26.0	1 1/64	16	5/8	5/8-16UN	0.65	23

*Air Hose Size (Inside Diameter) : 9.5mm (3/8") *Air Inlet Thread : NPT1/4"



UD-50S-45



UD-50S-22



UD-60S-29



UD-60S-04



UD-80S-12

SPECIFICATIONS

Recommended Air Pressure : 0.6MPa (85psi)

Model	Drilling Capacity		Free Speed (about)	Overall Length (about)		Weight with Chuck (about)		From Center to Outside (about)		Nominal Chuck Size		Type of Spindle	Average Air Consumption	
	mm	in	rpm	mm	in	kg	lb	mm	in	mm	in	in-thr'd	m ³ /min	ft ³ /min
UD-50S-200	3	No.5	23000	193	7 7/8	0.70	1.50	21.0	53/64	8	5/16	3/8-24UNF	0.40	14
UD-50S-45	6	1/4	5000	210	8 9/32	0.85	1.87	21.0	53/64	8	5/16	3/8-24UNF	0.40	14
UD-50S-22	8	5/16	2200	205	8 1/16	0.83	1.83	21.0	53/64	8	5/16	3/8-24UNF	0.40	14
UD-60S-29	8	5/16	2900	227	8 15/16	1.05	2.32	22.5	57/64	8	5/16	3/8-24UNF	0.50	18
UD-60S-20	8	5/16	2000	238	9 3/8	1.15	2.54	22.5	57/64	8	5/16	3/8-24UNF	0.50	18
UD-60S-15	8	5/16	1600	238	9 3/8	1.15	2.54	22.5	57/64	8	5/16	3/8-24UNF	0.50	18
UD-60S-07	13	1/2	700	272	10 23/32	1.35	2.98	22.5	57/64	13	1/2	1/2-20UNF	0.50	18
UD-60S-04	13	1/2	500	279	10 63/64	1.35	2.98	22.5	57/64	13	1/2	1/2-20UNF	0.50	18
UD-80S-12	13	1/2	1200	277	10 29/32	1.60	3.53	26.0	1 1/64	13	1/2	1/2-20UNF	0.65	23
UD-80S-07	13	1/2	700	300	11 13/16	2.10	4.73	26.0	1 1/64	13	1/2	1/2-20UNF	0.65	23
UD-80S-04	16	5/8	400	307	12 3/32	2.70	5.95	26.0	1 1/64	16	5/8	5/8-16UN	0.65	23
UD-80-12G	13	1/2	1200	282	11 7/64	2.30	5.06	26.0	1 1/64	13	1/2	1/2-20UNF	0.65	23
UD-80-07G	13	1/2	700	305	12 1/64	2.80	6.16	26.0	1 1/64	13	1/2	1/2-20UNF	0.65	23
UD-80-04G	16	5/8	400	313	12 21/64	3.40	7.50	26.0	1 1/64	16	5/8	5/8-16UN	0.65	23

*Air Hose Size (Inside Diameter) : 9.5mm (3/8") *Air Inlet Thread : NPT1/4"



UD-50S-22A

DRILL ADAPTER (for UD-50S Series)

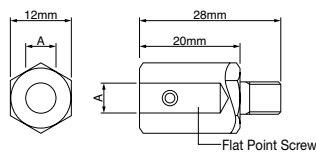

Drill Adapter

Dimensions A (mm)	Part Number
1.0	924-020-0
2.0	924-001-0
3.0	924-007-0
4.0	924-011-0
5.0	924-013-0
6.0	924-015-0
7.0	924-017-0
8.0	924-016-0

*Other sizes are also available. Please contact your nearest URYU distributors.



UD-60S-29C

CONE JAW CHUCK (for UD-50S Series)

Capacity : up to 1/4" or 6.35mm
Part Number : 923-100-0

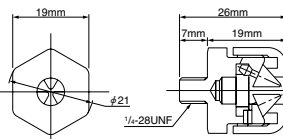

SPECIFICATIONS

Recommended Air Pressure : 0.6MPa (85psi)

Model	Drilling Capacity		Free Speed (about)	Overall Length (about)		Weight with Chuck (about)		Height with Chuck (about)		From Center to Outside (about)		Nominal Chuck Size		Type of Spindle	Average Air Consumption	
	mm	in		mm	in	kg	lb	mm	in	mm	in	mm	in		in-thr'd	m ³ /min
UD-50S-45A	4	No.8	5000	253	9 31/32	0.90	1.98	40	1 57/64	21.0	53/64	-	-	1/4-28UNF	0.40	14
UD-50S-22A	4	No.8	2200	248	9 49/64	0.88	1.94	40	1 57/64	21.0	53/64	-	-	1/4-28UNF	0.40	14
UD-60S-29C	8	5/16	2900	276	10 55/64	1.52	3.34	90	3 35/64	22.5	57/64	8	5/16	3/8-24UNF	0.50	18
UD-60S-15C	8	5/16	1600	283	11 9/64	1.60	3.52	90	3 35/64	22.5	57/64	8	5/16	3/8-24UNF	0.50	18

*Air Hose Size (Inside Diameter) : 9.5mm (3/8") *Air Inlet Thread : NPT1/4"

OPTION

Dead Handle Assembly



For UD-60 series 612-896-0
For UD-80 series 613-896-0

Head Sizes

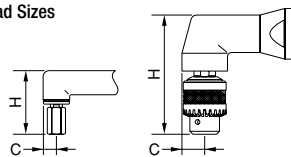

Model	C		H	
	mm	in	mm	in
UD-50S-22A	10.0	25/64	48.0	1 57/64
UD-60S-29C	17.0	43/64	90.0	3 35/64
UD-60S-15C	17.0	43/64	90.0	3 35/64

DRILLS & TAPERS

SELECTION GUIDE

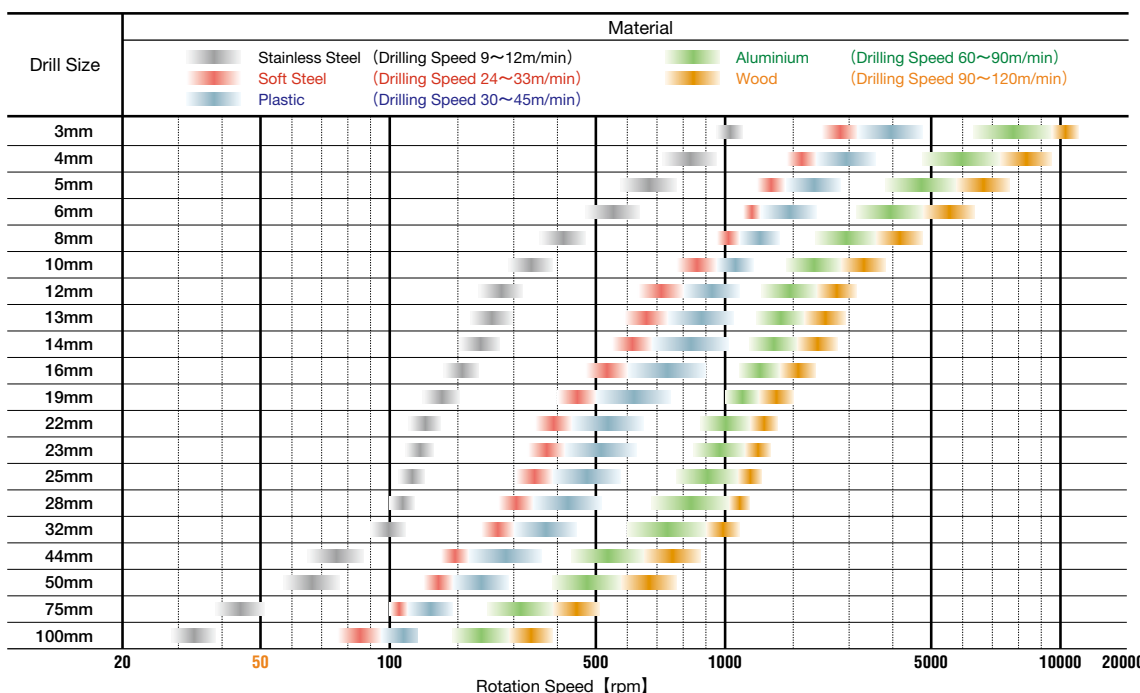

Tap Pilot Hole Size (mm)	
Bolt Size	Pilot Hole Size
M3	2.40
M4	3.25
M5	4.1
M6	5.0
M7	6.0
M8	6.8
M9	7.8
M10	8.5
M12	10.2
M14	12.0

DRILLS

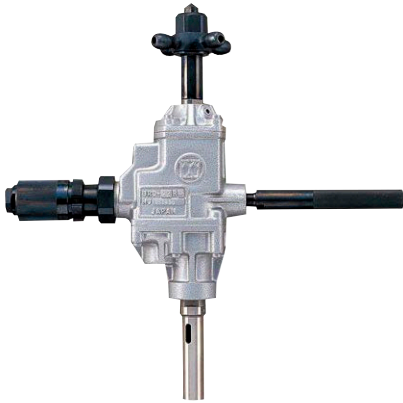

Smooth and accurate operations for many kinds of applications, such as drilling, tapping, reaming and tube rolling, etc.

SELF-RETURNING ROLL TYPE THROTTLE HANDLE

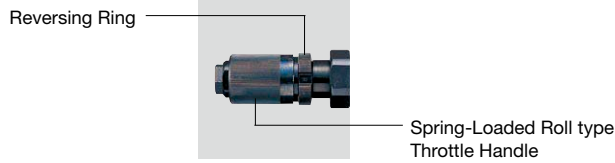

SPECIFICATIONS

Recommended Air Pressure : 0.6MPa(85psi)

Model	Type	Drilling Capacity		Free Speed (about)	Overall Length (about)		Weight (about)		From Center to Outside (about)		Feed Length (about)		Air Hose Size		Average Air Consumption	
		mm	in	rpm	mm	in	kg	lb	mm	in	mm	in	mm	in	m ³ /min	ft ³ /min
URD-22RR	Self-Returning	22.0	7/8	600	442	17 13/32	5.8	12.8	39	1 17/32	70	2 3/4	12.7	1/2	1.3	46

Air Inlet Thread : NPT3/8" for URD-22RR

TAPPERS

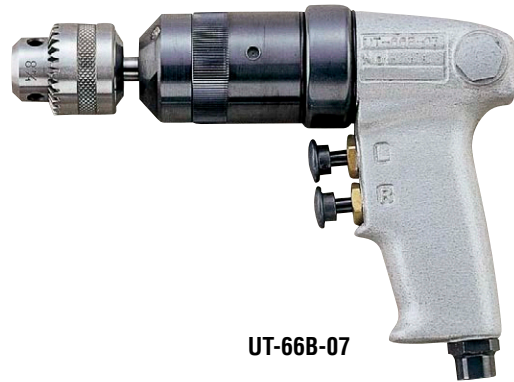

UT-66B-07

Double-Trigger Handle

UT-66 series reversible drills have the double trigger handle for quick and frequent switchover of rotation.

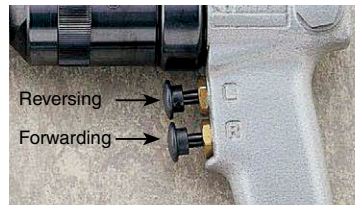

"Push-Pull" Auto Reversing Clutches

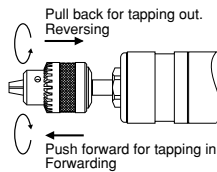

UT-60-04



UT-60S-07

Power is controlled by the built-in Air Regulator located on the handle.
UT-60-07
UT-60-04

OPTION

Size up of Chuck is possible.



923-060-0



923-053-0



682-732-0



678-732-7

Chuck Adaptor

Name	Part Number
φ13 Chuck	923-060-0
φ13 Taper Adapter	682-732-0
φ10 Chuck	923-053-0
φ10 Taper Adapter	678-732-7

*Tapping capacity is up to nominal Standard chuck size.

SPECIFICATIONS

Recommended Air Pressure : 0.6MPa (85psi)

Model	Tapping Capacity		Free Speed (about)	Overall Length (about)		Weight with Chuck (about)		From Center to Outside (about)		Average Air Consumption	
	mm	in	rpm	mm	in	kg	lb	mm	in	m ³ /min	ft ³ /min
UT-66B-15	6	1/4	1500	183	7 7/32	1.32	2.90	25.0	31/32	0.4	14.4
UT-66B-07	8	5/16	800	196	7 23/32	1.42	3.12	25.0	31/32	0.4	14.4
UT-60-07	8	5/16	680	244	9 39/64	1.80	3.96	22.5	57/64	0.5	18.0
UT-60-04	8	5/16	400	244	9 39/64	1.80	3.96	22.5	57/64	0.5	18.0
UT-60S-07	8	5/16	680	316	12 7/16	1.65	3.63	22.5	57/64	0.5	18.0
UT-60S-04	8	5/16	400	316	12 7/16	1.65	3.63	22.5	57/64	0.5	18.0

Air Inlet Thread : NPT1/4" for UT-66B-15~UT-60S-04 Air Hose Size : 9.5mm (3/8") for UT-66B-15~UT-60S-04
Nominal Chuck Size : 8mm (5/16") for UT-66B-07~UT-60S-04

PERCUSSION TOOLS

RIVETING HAMMERS
IMPACT CUTTERS
FLUX CHIPPERS
CHIPPING HAMMERS

RIVETING HAMMERS

SUPER VIBRATION-PROOF TYPE



BRH-1UD



BRH-1USD



BRH-5USD



BRH-5UD

SPECIFICATIONS

Recommended Air Pressure : 0.6MPa (85psi)

Model	Riveting Capacity				Blow Per Min. (about)	Overall Length (about)		Weight Less Rivet Set (about)		Piston Diameter (about)		Piston Stroke (about)		Air Inlet Thread (Pipe Tap)	Air Hose Size		Average Air Consumption		
	Duralumin		Steel			mm	in	kg	lb	mm	in	mm	in		in	mm	in	m ³ /min	ft ³ /min
	mm	in	mm	in															
BRH-1UD (R,H)	3.2	No.5	2.4	No.3	2800	143	5 5/8	1.40	3.1	14.30	9/16	38	1 1/2	NPT1/4	9.5	3/8	0.34	12.0	
BRH-5UD (R,H)	6.4	1/4	4.8	No.10	1800	211	8 5/16	1.65	3.6	12.70	1/2	100	4	NPT1/4	9.5	3/8	0.37	13.0	
BRH-1USD (R,H)	3.2	No.5	2.4	No.3	2800	272	10 45/64	1.60	3.5	14.30	9/16	38	1 1/2	NPT1/4	9.5	3/8	0.34	12.0	
BRH-5USD (R,H)	6.4	1/4	4.8	No.10	1800	340	13 25/64	1.90	4.2	12.70	1/2	100	4	NPT1/4	9.5	3/8	0.37	13.0	

STANDARD TYPE

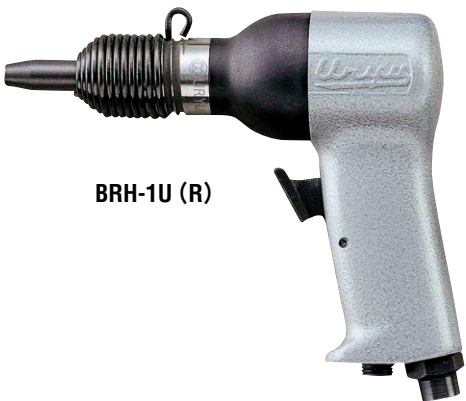

BRH-1U (R)



SBH-0



SBH-1A (R)



BRH-5U (R)



BRH-1US (R)

SPECIFICATIONS

Recommended Air Pressure : 0.6MPa (85psi)

Model	Riveting Capacity				Blow Per Min. (about)	Overall Length (about)		Weight Less Rivet Set (about)		Piston Diameter (about)		Piston Stroke (about)		Air Inlet Thread (Pipe Tap)	Air Hose Size		Average Air Consumption		
	Duralumin		Steel			mm	in	kg	lb	mm	in	mm	in		in	mm	in	m ³ /min	ft ³ /min
	mm	in	mm	in															
SBH-0	2.3	No.2	-	-	6500	123	4 27/32	0.32	0.7	10.00	25/64	23	29/32	NPT1/8	6.35	1/4	0.10	3.5	
SBH-1A(R,H)	2.6	No.3	-	-	4000	209	8 15/64	0.86	1.9	11.11	7/16	56	2 3/16	NPT1/4	6.35	1/4	0.15	5.0	
BRH-1U(R,H)	3.2	No.5	2.4	No.3	2800	122	4 15/16	1.05	2.4	14.30	9/16	38	1 1/2	NPT1/4	9.5	3/8	0.34	12.0	
BRH-1US(R,H)	3.2	No.5	2.4	No.3	2800	180	7 1/8	1.00	2.2	14.30	9/16	38	1 1/2	NPT1/4	9.5	3/8	0.34	12.0	
BRH-1UG(R,H)	3.2	No.5	2.4	No.3	2800	187	7 3/8	1.78	3.9	14.30	9/16	38	1 1/2	NPT1/4	9.5	3/8	0.34	12.0	
BRH-5U(R,H)	6.4	1/4	4.8	No.10	1800	189	7 7/16	1.40	3.1	12.70	1/2	100	4	NPT1/4	9.5	3/8	0.37	13.0	
BRH-5US(R,H)	6.4	1/4	4.8	No.10	1800	246	9 11/16	1.45	3.2	12.70	1/2	100	4	NPT1/4	9.5	3/8	0.37	13.0	
BRH-5UG(R,H)	6.4	1/4	4.8	No.10	1800	258	10 5/32	2.13	4.7	12.70	1/2	100	4	NPT1/4	9.5	3/8	0.37	13.0	

STANDARD ACCESSORIES

Model	Retainer Spring	Rivet Sets
SBH-0	①	a,b
SBH-1A (R)	②, ⑤	c,i
BRH-1U (R) Series	②, ⑤	d,i
BRH-1U (H) Series	②, ⑤	
BRH-5U (R) Series	④, ⑤	g,i
BRH-5U (H) Series	④, ⑤	

Rivet Set is not attached to the H type.

*Retainer Spring No. ③ and Rivet Set e/f/h are optional accessories.

SHANK SIZE for BRH-5U(H) series

BRH-5U(H) series

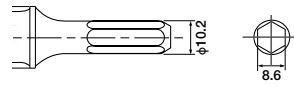

SPRING CHISEL RETAINER 876-179-1

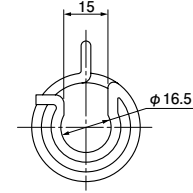

RIVETS for SBH & BRH Series

(mm)

	Retainer Spring		Rivet Set		Model	
	Part Number		Part Number			
Round Shank	①	700-810-1		a	920-810-0	SBH-0
				b	920-004-0	
	②	705-810-1		c	920-020-0	SBH-1A (R) BRH-1U (R) Series BRH-5U (R) Series
				d	920-021-0	
	③	710-811-1		e	920-030-0	SBH-1A (R) BRH-1U (R) Series BRH-5U (R) Series
				f	920-032-0	
	④	710-812-1		g	920-040-0	BRH-5U (R) Series
				h	920-042-0	
	⑤	876-179-1		i	920-800-0	SBH-1A (R) BRH-1U (R) Series BRH-5U (R) Series

IMPACT CUTTERS / FLUX CHIPPERS

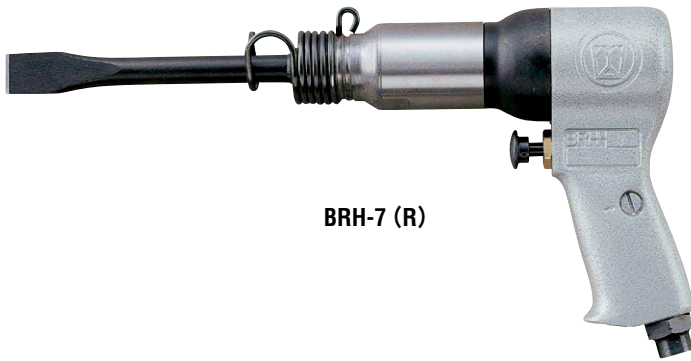



BRH-7 (R)



UFC-0N

OPTION

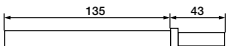
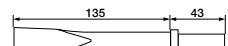
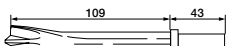
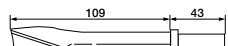
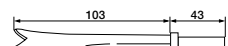
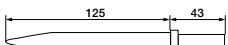
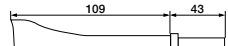
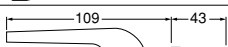
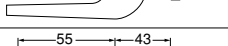
Chisels For BRH-7

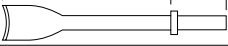
Chisel	Part Number	
	Round Shank	Hex. Shank
 Blank	○ 921-134-0(φ13) * 921-136-0(φ12.7)	○ 921-135-0(φ13) * 921-137-0(φ12.7)
 Flat	○ (7") 921-087-0	○ 921-127-0
 Sheet Metal(A)	○ 921-096-0	○ 921-115-0
 Sheet Metal(B)	921-092-0	921-117-0
 Spot Weld Breaker	○ 921-085-0	○ 921-125-0
 Taper Punch	921-091-0	921-121-0
 Bushing Remover	921-094-0	921-119-0
 Fork	921-097-0	921-122-0
 Hammer	921-098-0	921-123-0
 Scraper	○ 921-088-0	○ 921-128-0
 Tail Pipe Cutter	921-093-0	921-118-0
 Double Blade Panel Cutter	921-089-0	921-129-0

*If you use small Retainer Spring 705-810-1, use φ12.7 chisel. Standard Chisels are marked with "○"



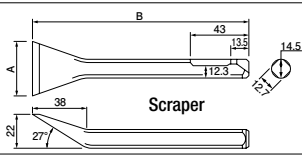
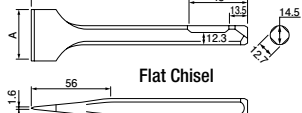

Chisels for UFC-0N, 1N

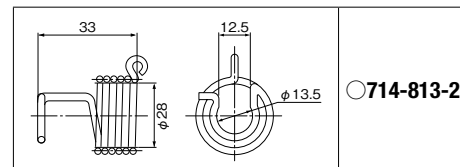
Chisel	Part Number	Dimension(mm)	
		A	B
 Scraper	○ 921-201-0	31.5	150
 Flat Chisel	921-202-0 921-206-0	35 60	158 140

BRH-7 Retainer Spring



Shank Size Of Rivet Sets

SBH-0	SBH-1A, BRH-1U & 5U	BRH-7	UFC series
			
Round Shank	Hex. Shank	Round Shank	Flux Chippers

SPECIFICATIONS

Recommended Air Pressure : 0.6MPa (85psi)

Model	Blow Per Min. (about)	Overall Length (about)		Weight Less Chisel (about)		Piston Diameter (about)		Piston Stroke (about)		Air Inlet Thread (Pipe Tap)	Air Hose Size		Average Air Consumption	
	bpm	mm	in	kg	lb	mm	in	mm	in	in	mm	in	m ³ /min	ft ³ /min
BRH-7(R,H)	3400	168	6 39/64	1.64	3.60	19.05	3/4	50	1 31/32	NPT1/4	9.5	3/8	0.48	17.0
UFC-0N	5300	180	7 1/8	1.38	3.04	25.00	63/64	28	1 1/4	NPT1/4	9.5	3/8	0.3	10.7
UFC-1N	4200	190	7 1/2	1.50	3.30	25.00	63/64	34	1 11/32	NPT1/4	9.5	3/8	0.3	10.7

R= Round Shank H=Hex. Shank BRH-7= with Built-in Air Regulator

CHIPPING HAMMERS

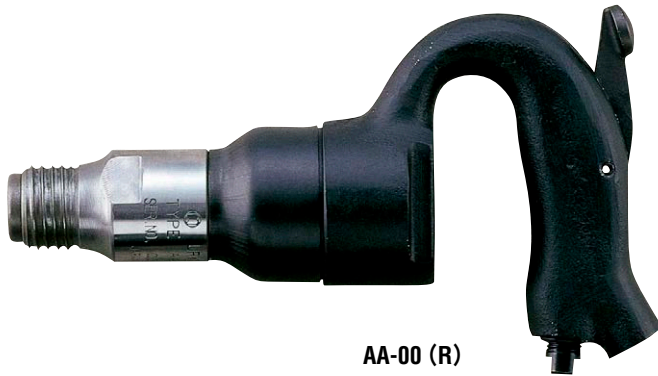

AA-00 (R)

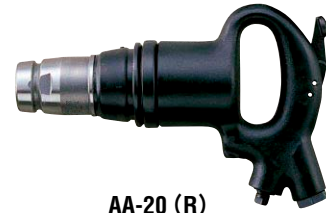

AA-20 (R)



PB-20 (R)

OPTION

CHISELS for AA-00 SERIES (Collared type)

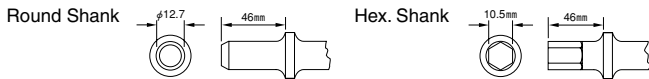

POINT shape	Overall Length		Part Number	
	mm	in	Round Shank	Hex.Shank
	200	7 7/8"	921-224-0	921-049-0
	176	6 15/16"	877-035-1	921-221-0
	220	8 21/32"	921-225-0	921-220-0

CHISELS for AA & PB SERIES

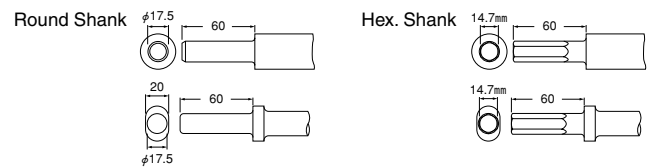

POINT shape	Overall Length		Part Number		
	mm	in	Plain Type	Collared Type	
	200	7 7/8"	R	921-021-0	921-072-0
			H	921-025-0	921-075-0
	220	8 21/32"	R	921-003-0	921-070-0
			H	921-010-0	921-073-0
	200	7 7/8"	R	921-056-0	921-071-0
	220	8 21/32"	H	921-055-0	921-074-0



Chisel Retainer Assembly 727-847-6
AA-20,30,40, PB-20,30 Standard Accessories.
(Chisel not included)

SPECIFICATIONS

Recommended Air Pressure : 0.6MPa (85psi)

Model	Chisel Shank Size				Blow Per Min. (about)	Overall Length (about)		Weight Less Chisel (about)		Piston Diameter (about)		Piston Stroke (about)		Air Inlet Thread (Pipe Tap)	Air Hose Size		Average Air Consumption	
	Round		Hexagonal			mm	in	kg	lb	mm	in	mm	in		mm	in	m ³ /min	ft ³ /min
	mm	in	mm	in														
AA-00(R,H)	12.7	1/2	10.5	3/8	2700	228	8 31/32	2.3	5.00	20.0	25/32	50	1 31/32	NPT3/8	9.5	3/8	0.35	12.3
AA-20(R,H)	17.5	5/8	14.7	9/16	2300	270	10 5/8	5.3	11.60	28.0	1 7/64	55	2 5/32	NPT3/8	12.7	1/2	0.60	21.1
AA-30(R,H)	17.5	5/8	14.7	9/16	2000	298	11 23/32	5.7	12.50	28.0	1 7/64	79	3 1/8	NPT3/8	12.7	1/2	0.60	21.1
AA-40(R,H)	17.5	5/8	14.7	9/16	1450	340	13 3/8	6.1	13.40	28.0	1 7/64	111	4 3/8	NPT3/8	12.7	1/2	0.60	21.1
PB-20(R,H)	17.5	5/8	14.7	9/16	1900	350	13 25/32	6.6	14.50	28.5	1 1/8	76	3	NPT3/8	12.7	1/2	0.80	28.0
PB-30(R,H)	17.5	5/8	14.7	9/16	1500	397	15 5/8	7.1	15.60	28.5	1 1/8	102	4 1/62	NPT3/8	12.7	1/2	0.80	28.0

PERCUSSION TOOLS

Compressor

Theoretical Consumption Energy of Compressor

You can refer to the table 1 to find the theoretical consumption energy of compressor, which is created through the adiabatic compression, to compress 1m³/min (normal cubic meter per minute) of free air to the various pressure levels. It is highly recommended that you should make the consumption energy value greater than the actual value by taking into consideration the machine efficiency including friction loss caused by compressor.

The consumption energy of compressor providing a pneumatic tool with 1m³/min (normal cubic meter per minute) of air at the gauge pressure 0.6MPa will be some 6.5kW or larger, if we consider the possible losses.

Energy Needed for Compressor

$$Q \geq 6.5 \text{ kW} \times (V \times n + V \times n + V \times n \dots) \times K \times S \times \alpha$$

Q : Energy needed for compressor (kW)

V : Air consumption per tool (m³/min (normal cubic meter per minute))

n : Number of tool

K : Coefficient of multiple tools in operation (table 2)

S : Coefficient of tool usage (table 3)

① Continuous operation: 1.0

Tool model for this category: Grinder, Sander, and Percussion Tool

② Discontinuous operation: 0.5

Tool model for this category: Oil-pulse tool, Impact Wrench, and Screwdriver

α : Loss caused by air leakage from connection between pipes

The table 4 refers to the major compressor power, which is sorted by tool category and model number, to operate a tool based on the catalogue air consumption value.

It takes long for a tool to complete a job at 0.4MPa as a compressor generates less power. On the other hand, it will not take long for a tool to do at 0.6MPa as a compressor generates more power. You should decide which helps you save cost, based on your various applications.

The table 2 gives you an idea of coefficient of operation. The value to operate a number of tools simultaneously is smaller as there are an increasing number of tools in operation.

The air consumption rate refers to the value in which a tool is used continuously for 1 minute. It is recommended, as shown in the table 3, that you should make the consumption energy value smaller than the actual value when you operate tools in the above-mentioned discontinuous operation and that you should make the consumption energy value larger than the actual value when you operate tools in the above-mentioned continuous condition.

Table 1

Gauge pressure	Single Stage Compression (Adiabatic Compression)		
	Theoretical Consumption Energy	Machine Efficiency (15% Included)	Various Losses (30% Included)
MPa	kW	kW	kW
0.3	2.84	3.27	4.25
0.4	3.41	3.92	5.10
0.5	3.91	4.49	5.84
0.6	4.35	5.00	6.50
0.7	4.74	5.45	7.09

Table 2

Number of Tool	Coefficient of Multiple Tools in Operation
1~5	1.0
6~10	0.8
11~20	0.7
21~30	0.6
31~50	0.5
50~100	0.4

Table 3

Operation	Coefficient of Tool Usage
Continuous Operation	1.0
Discontinuous Operation	0.5

Table 4

Category	Tool Model	Air Consumption	Energy Needed for Compressor
		m ³ /min	(kW)
Oil-pulse Tool	UAT60	0.35	2.28
	UL90	0.53	3.45
Impact Wrench	UW-6SK	0.30	1.95
	UW-13SK	0.55	3.58
Screwdriver	US-3.5A	0.20	1.02
	US-5W	0.30	1.53
Grinder	UG-38N	0.40	2.60
	USG-7S	1.10	7.15
Drill	UD-60-29	0.50	3.25
	UD-80-12	0.65	4.23
Percussion Tool	SBH-1A	0.15	0.98
	BRH-7	0.45	2.93

Note: Value for tools except Screwdriver: 0.6MPa at gauge
Value for Screwdriver: 0.4MPa at gauge.

TESTERS & ACCESSORIES

DIGITAL TORQUE TESTERS
TESTERS
ACCESSORIES

DIGITAL TORQUE TESTERS

UDT-200 & UDT-500

UDT-200 & UDT-500 series help you check the performance of oil-pulse tool and hand torque wrench at regular intervals, allowing you to store and download the data.

FEATURES

The built-in NiMH battery operation gives you hand-carry mobile use in your assembly site especially for pulse-tools' commencement of one day operation. AC power source from your plug can be used together.

11-hour continuous operation by battery is possible. Full recharging time is approx. 4-hours.

Memory function can store maximum 250 torque data.

Torque check and adjustment for angle nutrunner and shut-off pulse tool using optional soft-joint attachment for traceability.

Red color LED display gives clear visual confirmation.

PC output terminal RS-232C is built in the UDT series.

Torque transducer mounted in pick-up has optimum function to measure oil-pulse tool.



SPECIFICATIONS

Model	Recommended Torque Capacity Range	Blow Capacity Range	Accuracy	Dimensions mm(about) (W × D × H)	Weight Kg(about)	Accessories Socket Adapter
UDT-200A (115V) -200E (230V)	15-200N.m 10-150ft.-lb 150-200kgf.cm	0-99 blows (*)	±0.5% at rated output	Amplifier (198 × 171 × 115) Pick-up (245 × 125 × 75)	Amplifier (1.7) Pick-up (8.5)	(3/8) 836-520-0 (1/2) 836-520-1
UDT-500A (115V) -500E (230V)	150-500N.m 110-370ft.-lb 15-50kgf.m	0-99 blows (*)	±0.5% at rated output	Amplifier (198 × 171 × 115) Pick-up (280 × 150 × 90)	Amplifier (1.7) Pick-up (15.0)	(1/2) 836-520-7 (5/8) 836-520-8 (3/4) 836-520-9

(*) On condition that blow measurements start when input torque exceeds 60% of peak torque. Operating Voltage: 120V for UDT-**A , 220V for UDT-**E Operating Environment: (10-40°C) Humidity (20-80%), No Dew.

OPTION

Soft-joint Attachment Assembly

UDT-200

For pulse tools or angle nutrunner



(M8) 878-740-1



(M10) 836-890-7



(M12) 836-890-9



(M14) 878-840-1

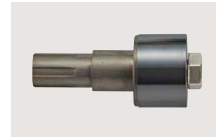

(M16) 878-800-1



(M18) 878-804-1

For angle nutrunner



(M8) 836-890-1



(M10) 836-890-2



(M12) 836-890-5



(M20) 878-807-1

Choose the correct size for your usage.

Other optional soft-joint attachment assemblies are available. Contact the URYU distributor close to you.

UDT-25

UDT-25 is designed to check fastening torque and its number of pulses for the small models (e.g. UL30, 40 and UAT30D · 40 · 50) with the torque capacity range 0.3 Nm-25 Nm.

FEATURES

Compact design for torque measurement and torque display sections gives hand-carry mobile.

Power source is nickel hydride battery. Full recharging time is approx. 4-hours. 11-hour continuous operation is possible after full charging. *1

Applicable to reversing torque as well. *2

UDT-25 tester can be used to check the capacity of US-LT, US-LD, and hand-held torque wrench as well.

Red color LED display gives you clear visual confirmation.

Supreme accuracy of within $\pm 0.5\%$ at the rated output.

The RS232C port for data output is built in the UDT-25 tester.

Data storage capacity: 250 data points.



*1: Never use during charging.

*2: Only forward rotation is available for Soft-Joint Attachment.

SPECIFICATIONS

Model	Applicable Tool Type	Recommended Torque Capacity Range	Blow Capacity Range	Accuracy	Power Source	Dimensions mm (about)	Weight kg (about)	Accessories
UDT-25A (115V)	Pulse Wrench, Torque Control Screwdriver, Direct Drive Screwdriver, Angle Nutrunner, Hand Torque Tester	0.3 - 25 Nm (2 - 25 Nm)	0 - 99 blows (*)	$\pm 0.5\%$ at rated output	Built-in Nickel Hydride Battery	190 (W) × 180 (D) × 59 (H)	2.3	Carrying Case 910-952-0
AC Adapter (115V) 910-950-0								
UDT-25E (230V)								AC Adapter (230V) 910-951-0
								Test Socket (3/8") 830-520-6
								Hexagon Socket Bit (13 × 100) 918-223-0
								Driver Adaptor 919-700-0
								Soft Joint Attachment 830-890-6
								Soft Joint Attachment 830-890-7
								Hexagon Head Bolt (M8 × 20) 946-928-0

(*) On condition that blow measurements start when input torque exceeds 60% of peak torque. Operating Environment : (10-40°C, no freeze) Humidity(20-80%), No Dew

Soft joint Attachments



830-890-6 / For Pulse Tools



830-890-7 / For Screwdrivers

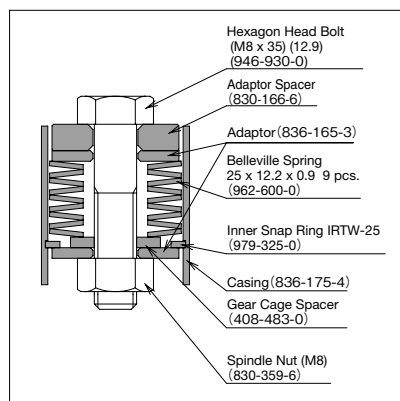
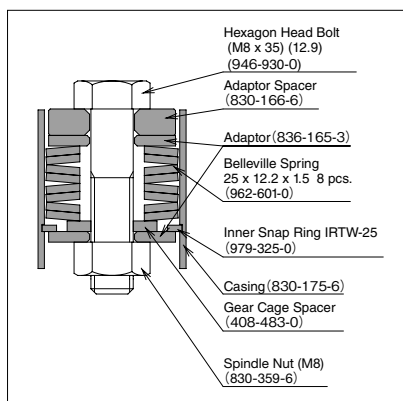

DIGITAL TORQUE TESTERS

UET SERIES

URYU UET-10CRA/10CRE torque tester is designed to check output torque of US-LT series Torque-Control Screwdriver. Its built-in torque sensor shows the torque reading on LED display.



Never use during charging.

FEATURES

Its built-in torque sensor reads the torque ranging from 0.1 to 10 Nm.

LED digital display helps you read the reading in the darkness.

Hit the RESET button for zero point adjustment.

Supreme accuracy: within $\pm 0.5\%$.

The CAL diagnostic features help you find any error in the built-in amplifier.

The portability with a built-in battery helps you check tools on site.

The soft-joint attachment comes standard with UET-10CR tester, which allows you to simulate the actual application.

The RS232C port for data output is built in the UET-10CR tester.

SPECIFICATIONS

Model	Recommended Torque Capacity Range	Accuracy	Power Source	Environmental Condition	Dimensions (unit: mm)	Weight (about)	Accessories
UET-10CRA (115V)	0.1 - 10 Nm (0.15 - 10 Nm)	$\pm 0.5\%$ at rated output	Built-in Ni-Cad Battery	Operation Temperature: 0 - 40°C (No Dew) Humidity: 30 - 90% (No Dew)	160 (W) × 190 (D) × 65 (H)	2.3 kg	Carrying Case 909-418-0
UET-10CRE (230V)							AC Adapter (115V) 910-904-0
							AC Adapter (230V) 910-905-0
							Hexagon Socket Bit (13 × 100) 918-129-0
							Hexagon Socket Bit (13 × 100) 918-223-0
							Driver Attachment Assembly 836-890-4
							Hexagon Head Bolt (M8 × 20) (12.9) 946-928-0
							Plate Spring 25 × 12.2 × 1.5 962-601-0

Driver Attachment Assembly



836-890-4

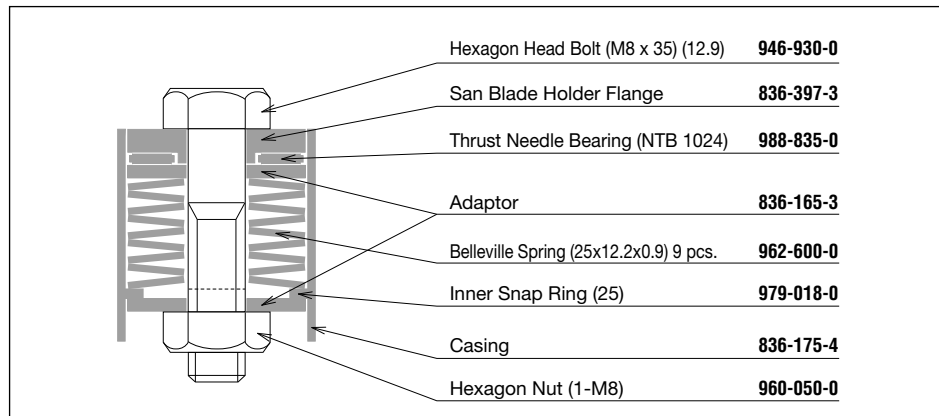

Usage of Testing Attachment

Soft Joint

Typically 3 turns to full torque after the bolt head or nut seats on the surface.

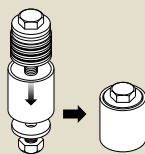

Apply Plate Springs, Testing Bolt (for soft-joint test) Spacer, Nut, and Casing. The Plate Springs are available in both weak and strong tensions.

Hard Joint

Typically 1/10 turn to full torque after the bolt head or nut seats on the surface



Apply Testing Bolt (for heard joint test) and Nut (without Casing, Spacer and Plate Spring).

TESTERS

UFT SERIES HYDRAULIC TESTER

Verify tool's performance with UFT prior to start of daily operation and you will find out less power on tools that can cause under torque troubles during the operation.



UFT-6



UFT-10



UFT-16

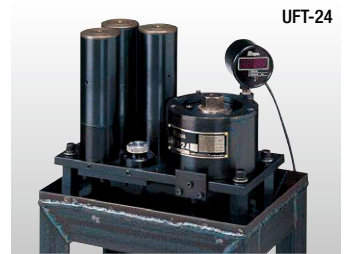

UFT-24

FEATURES

- Hard and Soft joint can easily be changed.
- Equipped with digital display.
- Shift between Torque value and tension value can easily be changed.
- Decimal point can also be moved easily.
- Applicable for pulse tools, impact wrenches, angle nutrunner, and any other fastening tools.

SPECIFICATIONS

Model	Bolt Size	Tension Range (kN)	Torque Range (Nm)	Weight (about)	
				Kg	lb
UFT-6	M5	3.6-6.1	3.2-5.4	3.6	7.9
	M6	5.1-13.9	5.4-14.7		
UFT-10	M6	5.1-13.9	5.4-14.7	12.0	26.4
	M8	10.4-22.2	14.7-31.4		
	M10	17.8-30.6	31.4-53.9		

Model	Bolt Size	Tension Range (kN)	Torque Range (Nm)	Weight (about)	
				Kg	lb
UFT-16	M12	25.5-41.7	53.9-88.2	22.0	48.4
	M14	35.7-60.3	88.2-149		
	M16	52.8-67.4	149-190		
UFT-24	M18	59.9-92.6	190-294	50.0	110.0
	M20	83.3-125	294-441		
	M24	104-162	441-686		

*Never provide UFT with torque greater than maximum torque or tension of each bolt size.

UHT SERIES HYDRAULIC TORQUE TESTER

The UHT-series simply designed hydraulic torque testers are suitable to be applied to Screwdrivers (Cushion, Positive, Impact Clutch types), Impact Wrenches and similar Impact action fastening tools in monitoring torque output of new and repaired tools in comparison with their master tools. The readout in the dial indicator does not show absolute torque value, but just comparative degree of power of the tool being tested.



UHT-35

UHT-25

UHT-12



UHT-50

SPECIFICATIONS

Model	Applicable Tool Type or Square Drive Size	Applicable Torque Range		Weight (about)	
		Nm	ft-lbs	Kg	lb
UHT-12	Cushion/Positive Clutch	1-8	0.7-5.9	2.5	5.5
UHT-16	Impact Clutch	3-20	2.2-14.8	7.5	16.5
UHT-25	3/8"(9.5mm)	20-50	14-36	13.0	28.6
UHT-35	1/2"(12.7mm)	50-300	36-215	19.0	41.8
UHT-50	3/4"-1"(19.0-25.4mm)	300-2000	215-1450	150.0	330.0

ACCESSORIES

Air Regulator Assembly

Item	Dimensions			Part Number
	D1	D2	L (mm)	
Air Regulator Assembly 1/8	NPT1/8	NPT1/8	42	932-100-0
Air Regulator Assembly 1/4	NPT1/4	NPT1/4	42	932-110-0

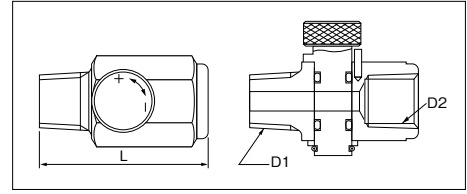

Lock Plug

Item	Dimensions				Part Number
	T	L (mm)	A (mm)	C (mm)	
Lock Plug NPT1/4	NPT1/4	43	14.7	20.3	933-042-0
Lock Plug NPT3/8	NPT3/8	45	16.7	20.3	933-043-0

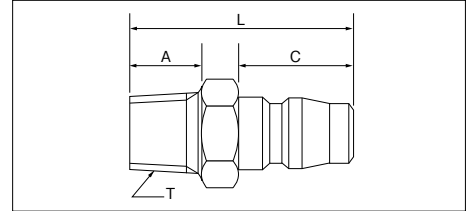

Spanner

Item	Dimensions			Part Number	Used for	
	S (mm)	L (mm)	t (mm)			
A	Spanner 8×2×90	8	90	2	936-100-0	UD-50S-22A
	Spanner 17×3.2×135	17	135	3.2	936-051-0	UG-65/650E
	Spanner 21	21	173	5	936-521-0	AG-50, AG-50L
	Spanner 29×4.76×150	29	150	4.76	936-054-0	USG-4S
	Spanner 32×4×150	32	150	4	936-072-0	AG-100S, AG-100SL
B	Spanner 12	12	125	4.5	936-512-0	UD-50S-22A
	Spanner 14	14	145	4.5	936-514-0	UG-25NA, UG-25NSA UG-20A-120, UG-20A-200 UG-38N, UG-38NA, UG-38NS, UG-38NSA UG-38NL, UG-38NSL, UG-50S-200A
	Spanner 17	17	159	4	936-517-0	UG-25NA, UG-25NSA UG-20A-120, UG-20A-200, UG-65/650E
	Spanner 23×5×195	23	195	5	936-053-0	USG-7S
	Spanner 26×5×195	26	195	5	936-004-0	UP-80-40

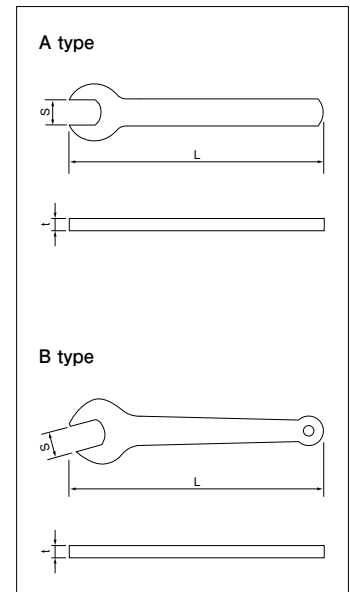

Tool Holders

	Dimension (mm)							Part Number	Used for
	A	B	C	D	E	F	G		
Small	φ34	φ49	φ54	38	60	100	84	852-644-1	ULT30D~70 SERIES, UAT30D~70 SERIES, UL30~70 SERIES, UX-450~500 SERIES, US-5PW, -6PW, UD-50-200, -45, -22, UD-60-29, -20, -15, UT-66B-15
Middle	φ36	φ54	φ68	38	66	115	106.5	852-669-1	ULT70~90 SERIES, UAT70~90 SERIES, UL70~90 SERIES, UL40MC~90MC, UA40MC~90MC, UDBP-(T, A, TA)40~60 SERIES, UX-612~700 SERIES, -T700~T800 SERIES, UW-6SLRK, -6SLK, -6SAK, -6SHAK, -6SHK SERIES, UW-6SARK, -6SBRK, -6SHBRK, -B6SLK, -ST6SHK SERIES
Large	φ50	φ74	φ78	42	80	125	115	852-645-1	ULT90~130 SERIES, UAT90~130 SERIES, UL90~130 SERIES, UL100MC, UA100MC, UDBP-(T, TA)70 SERIES, UX-T700~T900, -800~900, -ST800 SERIES, UW-6SK, 6SHK, -8SHK, -8SHRK, -9SRK SERIES

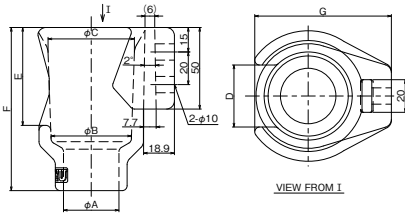

Motor Oil (200mL) 998-725-0



Hexagonal Sockets

Part Number	Dimensions of Sockets (mm)					Sq.Drive F
	A	B	C	D	E	
900-028-0	16	19	5.3	9.4	10	9.5
900-044-0	20	21	5.5	11.4	11	
900-056-0	22	25	6.5	12.0	13	
900-064-0	22	25	6.5	15.4	14	
900-132-0	23	30	6.5	14.0	13	
900-140-0	24	30	6.5	14.0	14	12.7
900-153-0	28	31	7.5	15.0	17	
900-170-0	30	35	8.5	15.0	19	
900-176-0	35	38	9.5	18.0	21	
900-187-0	36	40	9.5	19.0	22	
900-193-0	37	41	10.0	20.0	23	19.0
900-342-0	40	48	11.0	21.0	24	
900-347-0	43	49	12.0	22.0	26	
900-360-0	45	50	14.0	23.0	27	
900-377-0	48	52	15.0	27.0	30	

Part Number	Dimensions of Sockets (mm)					Sq.Drive F
	A	B	C	D	E	
900-380-0	50	54	15.0	29.0	32	19.0
900-390-0	54	57	17.0	32.0	35	
900-400-0	55	58	17.0	33.0	36	
900-464-0	54	57	15.0	29.0	32	
900-475-0	54	60	17.0	32.0	35	
900-483-0	56	60	17.0	32.0	36	25.4
900-499-0	62	66	19.0	38.0	41	
900-512-0	68	70	21.0	42.0	46	
900-587-0	70	70	21.0	35.0	46	
900-605-0	82	80	27.0	45.0	54	
900-609-0	82	80	27.0	45.0	55	
900-610-0	88	83	29.0	48.0	58	
900-613-0	90	86	30.0	51.0	60	
900-653-0	100	98	33.0	53.0	67	
900-660-0	115	103	38.0	58.0	77	38.1

Part Number	Dimensions of Sockets (mm)					Sq.Drive F
	A	B	C	D	E	
900-664-0	120	107	40.0	62.0	80	38.1
900-666-0	125	111	43.0	66.0	85	
900-694-0	120	114	38.0	68.0	77	
900-697-0	125	117	41.0	71.0	80	44.4
900-700-0	145	130	48.0	84.0	95	
900-706-0	165	140	60.0	94.0	110	
900-744-0	164	140	60.0	89.0	110	50.8

HEXAGONAL SOCKETS

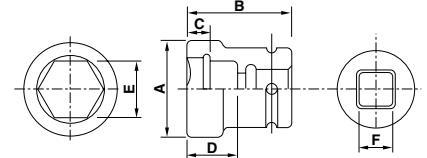

Sockets for Stud-Bolt Driving

Part Number	Nominal Bolt Sizes Dimensions of Sockets (mm)								Model
	mm	in	A	B	C	D	E	F	
903-002-0	6	-	16	29	9.0	M6	5/32	9.5	UW-ST6SHK
903-035-0	-	1/4	16	19	9.0	W1/4-20	5/32	9.5	UW-ST6SSHK
903-003-0	8	-	17	35	16.0	M8	7/32	9.5	UX-ST800
903-103-0	8	-	17	39	16.0	M8	7/32	12.5	UW-ST9SK
903-105-0	10	-	19	41	18.5	M10	9/32	12.5	UW-ST10SHK

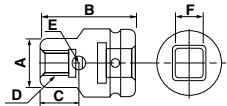

Bit Chuck Assembly

Part Number	A	B	C	D
907-000-0	22	41	6.35Hex	9.5Sq
907-050-0	24	46	8.0Sq	12.7Sq

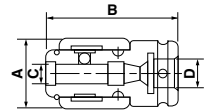

Please do not use UX-1000/UW-10SHK or bigger models as the torque is too strong to use with the above.

Joint Assembly

Part Number	A	B	C
906-000-0	45	20	9.5
906-020-0	69	30	12.7
906-040-0	84	46	12.7

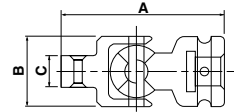

SPECIAL EXTENSION BARS FOR OIL-PULSE TOOLS

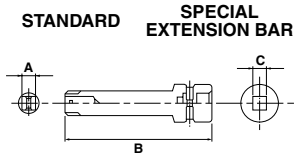
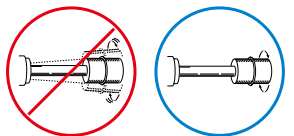

For tool optimum performance these extension bars are especially designed for deeper engagement with tool anvils to minimize torque-down and wobbling.

Part Number	B (mm)	A&C Sq.Drive	Socket Retainer Type	Models
904-049-0 904-050-0 904-051-0 904-075-0 904-052-0 904-054-0	75 100 150 190 254 300	9.5mm (3/8")	OP-P TYPE	UX-450 UL(T)60(S) UX-500 UL(T)70(S) UX-612 UL(T)80 UX-(T)700(L) UAT40(S) UX-(T)800 UAT50(S) UL30 UAT60(S) UL(T)40(S) UAT70(S) UL(T)50(S) UAT80
904-155-0 904-156-0 904-157-0	76 125 204	12.7mm (1/2")	OP-P TYPE	UX-(T)900

Part Number	B (mm)	A&C Sq.Drive	Socket Retainer Type	Models
904-168-0 904-169-0 904-172-0 904-173-0	76 125 204 355	12.7mm (1/2")	OP-P TYPE	UX-(T)1000 UX-(T)1300 UX-(T)1400 UL(T)90 UL(T)100 UL(T)130 UAT90 UAT100
904-353-0	200	19.05mm (3/4")	O-RING TYPE	UX-(T)1620 UXR-(T)1820 UXR-2000(S) UXR-(T)2000 UL(T)150 UL(T)180 UAT150 UAT180 UAT200
904-455-0	200	25.4mm (1")	O-RING TYPE	UXR-2400S UXR-3000S

OPERATOR'S SAFETY MANUAL FOR URYU POWER TOOLS



Safety Instructions

General Safety

- Only qualified and trained operators should install, adjust or use the tool.
- Do not modify the tool. Modifications can reduce the effectiveness of safety measures and increase the risks to the operator.

Work Area Safety

- Keep work area clean and well lit. Cluttered or dark areas invite accidents.
- Do not use the tool in potentially explosive atmospheres, such as in the presence of flammable liquids, gases or dust.
- Always secure workpiece. Use clamps or other practical way to secure and support the workpiece to a stable platform.
- Be aware of slippery surfaces caused by use of the tool and of trip hazards caused by the air line.
- Keep bystanders and visitors away while operating the tool. Distraction can cause you to lose control.

Personal Safety

- Maintain a balanced body position and secure footing. Avoid awkward or off-balanced postures.
- Prevent unintentional or inadvertent start. Ensure that the throttle trigger / lever is in the off-position before connecting the tool to air supply, picking up or carrying the tool. Carry the tool only by the handle. Carrying the tool with your finger on the throttle trigger / lever or energising the tool that has the throttle trigger / lever on invites accidents.
- Dress properly. Do not wear loose clothing, jewellery and neck ware. Keep your hair, clothing and gloves away from all moving parts.
- Use personal protective equipments such as dust mask, non-skid safety shoes and hard hat as instructed by the employer and as required by occupational health and safety regulations.
- Wear suitable gloves to protect hands against hazards such as crushing, impacts, cuts and abrasions and heat.



-Always wear impact-resistant eye protection during the operation of the tool. The grade of protection required should be assessed for each use.

-Remove any adjusting wrench before turning the tool on. A wrench that is left attached to a rotating part of the tool may result in personal injury.

-Ensure that the workpiece is securely fixed.



Noise

-Use hearing protection in accordance with employer's instructions and as required by occupational health and safety regulations. Look after your hearing protection.

-Always ensure that the silencer is in place and in good working order when the tool is operating.

Vibration

- Support the weight of the tool in a stand, tensioner or balancer if possible.
- Hold the tool with a light but safe grip taking account of the required hand reaction forces. The risk from vibration is generally greater when the grip force is higher.
- Wear warm clothing when working in cold conditions and keep your hands warm and dry. Direct cold air away from the hands.
- Use sleeve fittings where practicable.

Dust and Fumes

- Direct the exhaust so as to minimise disturbance of dust in a dust-filled environment. Where dusts or fumes are created, the priority shall be to control them at the point of emission.

Pneumatic Safety

- Do not exceed the maximum air pressure stated on the tool.
- Use correct hoses and always check for damaged or loose hoses and fittings. Whipping hoses can cause severe injury.
- Do not abuse the hose. Never use the hose for carrying, pulling or hanging the tool.
- Keep the hose away from heat, oil, sharp edges or moving parts. Damaged or entangled hoses increase the risk.
- Never direct air at yourself or anyone else.

Electrical Safety

- Do not handle the tool, controller, battery or charger with wet hands.
- Do not expose the tool, controller, battery and charger to rain or wet conditions.
- Do not abuse the power cable. Do not pull the power cable for carrying the tool, controller or charger or disconnecting the power plug from the power point.
- Arrange the power cable so that it may not be stepped, caught or stressed for damages.
- Do not attempt to open, disassemble, modify or service the battery pack.
- Do not crush, puncture, shorten external contracts or circuits, dispose of in fire or water. Keep the battery away from metal objects such as paper clips, coins, keys, screws or other small metal objects that can lead to short circuit.
- Do not expose batteries to temperatures above 40°C.
- Keep the battery and charger dry and away from water or any liquid as it may cause a short circuit.
- Do not use a battery that appears damaged, deformed or discoloured or the one that has any rust on its casing, overheats or emits a foul odour.
- Do not attempt to solder anything to the battery. It will dissolve insulations, destroy the gas exhaust valve or the protection circuit.
- Do not place any object on the charger nor cover the battery with flammable things while charging.
- Leaks from battery cells can occur under extreme conditions. Do not allow the leaking fluid to come in contact with skin or clothing. If already in contact, flush the affected area immediately with clean water and seek medical advice. If the liquid comes in contact with eyes, DO NOT rub; rinse with clean water immediately for minimum 10 minutes and seek medical help. Liquid ejected from the battery may cause irritation or burns.
- Take extra precautions to keep a leaking battery away from fire as there is a danger of ignition or explosion.
- Do not use charger if it is damaged by a drop or is with a damaged power cable.

OPERATOR'S SAFETY MANUAL FOR URYU POWER TOOLS

Residual Risks

- Gloves can become entangled with the rotating drive, causing severed or broken fingers. Rotating drive sockets and drive extensions can easily entangle rubber coated or metal reinforced gloves.
- Additional residual risks may arise when using the tool which may not be included in the safety warnings. These risks can arise from misuse, prolonged use and so on. Even with the application of the relevant safety regulations and the implementation of safety devices, certain residual risks cannot be avoided. (e.g. injuries caused when changing any parts, blades or accessories)

Tool Use and Care

- Hold the tool correctly: be ready to counteract normal or sudden movements – have both hands available.
- Keep the tool dry and clean – free from oil and grease for better control of the tool.
- Do not force the tool. Use the correct tool for your application. The correct tool will do the job better and safer at the rate for which it is designed.
- Check for misalignment or binding of moving parts, breakage of parts and any other condition that may affect the tool operation. If damaged, get the tool repaired before use.
- Select and maintain and replace the socket / bit properly to prevent an unnecessary increase in noise / vibration level(s).
- Check attached tools such as sockets, grinding wheel etc. and replace them if worn or damaged.
- Clean the exhaust silencer and filter frequently or replace in order to prevent clogging and decreased power.
- Store the tool out of the reach of children and do not allow persons unfamiliar with these instructions to operate the tool. Tools are dangerous in the hands of untrained users.

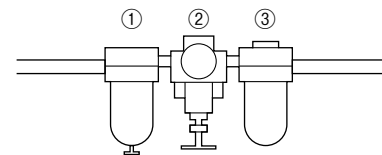
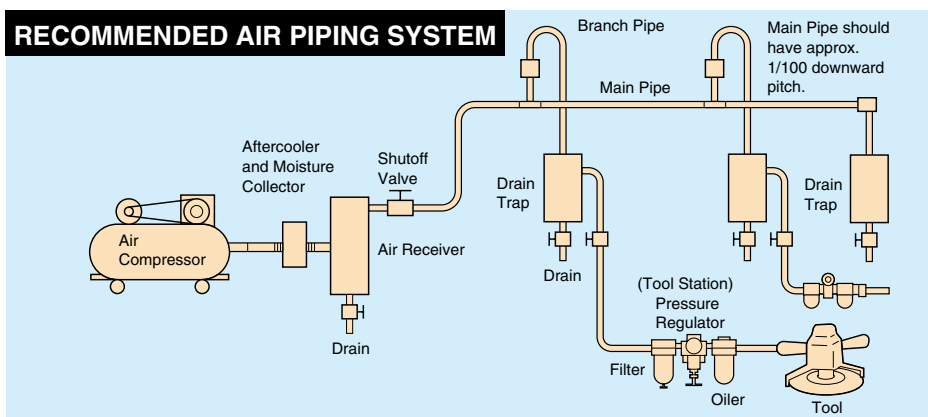

- ① **Air Filter** : removes water and dirt particles from compressed air.
- ② **Pressure Regulator** : gives steady and dependable regulation at 0.6MPa (85psi).
- ③ **Air Oiler (Lubricator)** : assures longer and more dependable tool life.

NOISE & VIBRATION



NOISE LEVELS AND VIBRATION VALUES

On 29 December 2009 EU new Machinery Directive, 2006/42/EC, came into force. Requirements concerning noise and vibration are made more precise. We, URYU SEISAKU, LTD., measured and declare noise levels and vibration emission values in accordance with EU Machinery Directive, 2006/42/EC.

Noise Levels

1) Measurement

Noise Levels are measured in accordance with ISO 15744 for hand-held non-electric power tools and EN62841-1 for electric power tools.

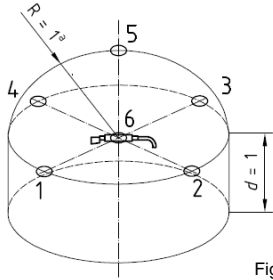

Figure 1 : Microphone Positions

Five microphone positions shall be located 1 m from the geometric centre of the tool. Four positions shall be spaced at regular intervals on a plane defined as passing through the geometric centre of the tool and parallel to the reflecting plane; the fifth position shall be located at a distance of 1 m above the geometric centre of the tool. See the figure 1.

2) Declaration

We declare sound pressure levels (L_p) and sound power level (L_w) in accordance with EU machinery directive, 2006/42/EC. Sound pressure levels are given as numbers when they are 70dB(A) or over. For tools with sound pressure levels lower than 70dB(A), we state < 70dB(A). If the sound pressure level exceeds 80dB(A), we also state the sound power level (L_w) which is 11dB(A) higher than the sound pressure level. To the measured level, 3dB(A) can be added to incorporate variations in production and method. ISO 15744 and EN62841-1 describes how to calculate these figures.

3) Risk Assessment & Risk Management

Noise is part of everyday life, but loud noise can permanently damage your hearing. Once you lose your hearing, you can never get it back. Generally hearing loss is gradual. By the time you notice it, it is probably too late. Manage the risk to exposure to noise at workplace to prevent hearing loss.



- Always use hearing protection in accordance with employer's instructions and as required by occupational health and safety regulations. Look after your hearing protection.
- Ensure that the silencer is in place and in good working order when the tool is operating.

We would recommend 'ISO 9612' for measurement and assessment of exposure to noise in a working environment, for risk assessment.

Vibration Values

1) Measurement

Vibration is measured according to the relevant part of ISO 28927 series. For some tools that are not covered by ISO 28927 series, ISO 20643 is used to develop a suitable test procedure.

The new Machinery Directive requires vibration total values. A vibration total value is based on a vibration measurement in three directions, x, y and z.

Ex. Measurement Locations for Pistol Grip Type Oil-Pulse Tools

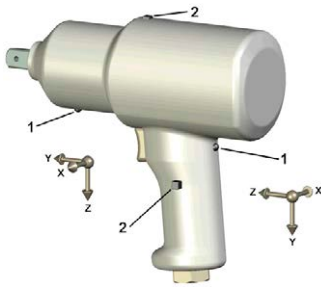

Figure 2 : without Support Handle

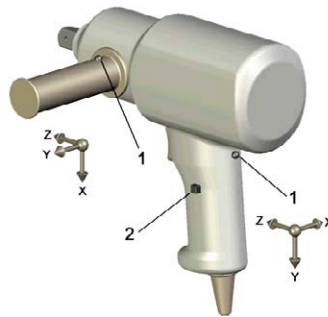

Figure 3: with Support Handle

Oil-pulse tools with a mass less than 2kg are normally operated using only one hand and therefore only the hand position on the trigger handle is measured. Tools of a mass of 2kg or more are normally operated using both hands and measurements are made in two positions. For tools without a side handle, the second hand position is on the front casing or – if that is not possible – on the motor housing (see figure 2). For tools with a side handle, vibrations are measured in three directions both on the trigger and the support handle (see figure 3). On the tools intended to be used with two hands, two positions are measured and the position with the higher value is declared.

The vibration total value (a_{hv}) is the vector sum of the three different directions (a_{hw_x} , a_{hw_y} & a_{hw_z}) at one transducer position. See the equation (1).

$$a_{hv} = \sqrt{a_{hw_x}^2 + a_{hw_y}^2 + a_{hw_z}^2} \quad \text{Equation (1) *See 6 Characterization of vibration, 6.4 Combination of vibration directions.}$$

Three different operators carry out three series of five consecutive measurements on each model, using three different units. Vibration measurement are made in two positions when the tool has mass of 2 kg or over (see figure 2) or when the tool has a support handle (see figure 3). For each hand position, we combine the result from the three operators into one value (\bar{a}_h), using the arithmetic mean of the three \bar{a}_{hv} values. \bar{a}_h values for each hand position are calculated as the arithmetic mean of the \bar{a}_h values for the different tools on that hand position. The declared value, a_{hd} , is the highest of the \bar{a}_h values reported for the two hand positions. The uncertainty K value is estimated by the equation (2).

$$K = 1.5\sigma \quad \text{Equation (2) *See Annex B Determination of uncertainty, B.3 Tests on three machines.}$$

2) Declaration

We declare vibration total values (A_{hd}) and measurement uncertainty (K). Vibration total values are to be given as numbers when they are 2.5m/s^2 or over. For tools with vibration total values lower than 2.5m/s^2 , we state $< 2.5\text{m/s}^2$. Measurement uncertainty K values are given as numbers.

NOISE LEVELS AND VIBRATION VALUES

3) Triaxial Vibration Values and Single Direction Vibration Values

There is no fixed relation between triaxial vibration values measured in accordance with ISO 28927 series and one single direction vibration values measured in accordance with ISO 8662 series. Therefore, it is adequate to compare values from the same tool type, referring to the same part of the same standard.

Attention ! ISO 28927-2 is applicable to all hand-held tools for threaded fasteners, but ISO 28927-2 adopts a procedure for testing tools with an impact or impulse mechanism using a test device based on break blocks acting on the outer diameter of a test socket, and a free running test for other type of tools without an impact or impulse mechanism. Therefore, it may not be adequate to compare a value from an oil-pulse tool (under load) and one from a nutrunner without impact or impulse mechanism (free running).

4) Risk Assessment & Risk Management

Using hand-held power tools may cause hand-arm vibration syndrome*1 and carpal tunnel syndrome*2. We recommend risk assessment and regular health checks of the workforce for early symptoms which may relate to vibration exposure to prevent problems developing.

*1: Hand-arm vibration syndrome affects the nerves, blood vessels, muscles and joints of the hand, wrist and arm. It includes vibration white finger, which can cause severe pain in the affected fingers.

*2: Carpal tunnel syndrome is a nerve disorder which may involve pain, tingling, numbness and weakness in parts of the hand, and can be caused by, among other things, exposure to vibration.

- Manage the risk by reducing the exposure to vibrations.
 - Employ work process or a tool which has lower vibrations.
 - Employ work process or a tool which can do the job more quickly.
- Check tools and accessories before using them to make sure that they have been properly maintained and repaired to avoid increased vibration caused by faults or general wear.
- Support the weight of the tool in a stand, tensioner or balancer if possible.
- Avoid gripping or forcing a tool more than you have to. The risk from vibration is generally greater when the grip force is higher.
- Encourage good blood circulation by:
 - keeping your hands warm and dry.
 - massaging and exercising your fingers during work breaks.

We would recommend 'ISO 5349-1' and 'ISO 5349-2' for human exposure to hand-transmitted vibration measurement at workplace, for risk assessment.

Noise & Vibration Emission Values

The declared values were obtained by laboratory type testing in accordance with the stated standards and are suitable for comparison with the declared values of other tools tested in accordance with the same standard. These declared values are not adequate for use in risk assessments. Values measured in individual work places may be higher. The actual exposure values and risk of harm experienced by an individual user are unique and depend upon the way the user works, the workpiece and the workstation design, as well as upon the exposure time and the physical condition of the user.

We, URYU SEISAKU, LTD., cannot be held liable for the consequences of using the declared values, instead of values reflecting the actual exposure, in an individual risk assessment in a work place situation over which we have no control.

The uncertainty in the sound levels is 3dB (A).

Pistol Grip Battery Pulse Tools	EN62841-1		ISO 28927-2 *measured under load	
	Sound Pressure Level (L _{pa})	Sound Power Level (L _{wa})	Vibration Total Value (A _{tot})	Vibration Uncertainty (K)
	dB(A)	dB(A)	m/sec ²	m/sec ²
UDBP-TA40	75	-	< 2.5	0.55
UDBP-TA40(P)	75	-	< 2.5	0.54
UDBP-TA50	76	-	< 2.5	0.56
UDBP-TA50(P)	76	-	< 2.5	0.54
UDBP-TA60	77	-	< 2.5	0.57
UDBP-TA60(P)	76	-	< 2.5	0.55
UDBP-TA70(P)	76	-	< 2.5	0.57
UDBP-A50	76	-	< 2.5	0.56
UDBP-A50(P)	76	-	< 2.5	0.54
UDBP-A60	77	-	< 2.5	0.60
UDBP-A60(P)	77	-	< 2.5	0.60

The noise measurement method of EN62841-1 is much aligned with ISO15744.

Pistol Grip Electric Pulse Tools	EN62841-1		ISO 28927-2 *measured under load	
	Sound Pressure Level (L _{pa})	Sound Power Level (L _{wa})	Vibration Total Value (A _{tot})	Vibration Uncertainty (K)
	dB(A)	dB(A)	m/sec ²	m/sec ²
UDP-TA40(B)/(B-TL)	70	-	< 2.5	0.55
UDP-TA40D(B)/(B-TL)	70	-	< 2.5	0.56
UDP-TA50(B)/(B-TL)	70	-	< 2.5	0.56
UDP-TA50D(B)/(B-TL)	70	-	< 2.5	0.56
UDP-TA55(B)/(B-TL)	70	-	< 2.5	0.57
UDP-TA55D(B)/(B-TL)	70	-	< 2.5	0.58
UDP-A60LMC,(TL)	74	-	< 2.5	0.60
UDP-A60MC,(TL)	74	-	< 2.5	0.60
UDP-A80MC,(TL)	76	-	< 2.5	0.63
UDP-A100MC,(TL)	76	-	< 2.5	0.63
UDP-A120MC,(TL)	78	-	< 2.5	0.64

The noise measurement method of EN62841-1 is much aligned with ISO15744.

Transducerized Pulse Tools	ISO 15744		ISO 28927-2 *measured under load	
	Sound Pressure Level (L _{pa})	Sound Power Level (L _{wa})	Vibration Total Value (A _{tot})	Vibration Uncertainty (K)
	dB(A)	dB(A)	m/sec ²	m/sec ²
UA40MC	78	-	< 2.5	0.53
UA40DMC	78	-	< 2.5	0.55
UA50MC	78	-	< 2.5	0.54
UA50DMC	78	-	< 2.5	0.55
UA60MC	80	-	< 2.5	0.54
UA70MC	80	-	< 2.5	0.55
UA80MC	80	-	< 2.5	0.56
UA90MC	82	93	< 2.5	0.58
UA100MC	82	93	< 2.5	0.60
UA130MC	82	93	< 2.5	0.63
UA150MC	83	94	2.7	0.7
UA40SMC	78	-	< 2.5	0.7
UA40SDMC	78	-	2.7	0.7
UA50SMC	78	-	2.7	0.7
UA50SDMC	78	-	3.0	0.7
UA60SMC	80	-	3.1	0.7
UA60SDMC	80	-	3.4	0.8
UA70SMC	80	-	3.3	0.7
UA400AMC	78	-	< 2.5	0.54
UA500AMC	78	-	< 2.5	0.55
UA600AMC	80	-	< 2.5	0.55
UA700AMC	80	-	< 2.5	0.56
UA800AMC	80	-	< 2.5	0.57
UA900AMC	82	93	< 2.5	0.57
UA1000AMC	82	93	< 2.5	0.60
UA1300AMC	82	93	< 2.5	0.60

Transducerized Pulse Tools	ISO 15744		ISO 28927-2 *measured under load	
	Sound Pressure Level (L _{pa})	Sound Power Level (L _{wa})	Vibration Total Value (A _{tot})	Vibration Uncertainty (K)
	dB(A)	dB(A)	m/sec ²	m/sec ²
UXR-1820MC	84	95	< 2.5	0.6
UXR-2000MC	85	96	2.7	0.7

NOISE LEVELS AND VIBRATION VALUES

Straight Type Transducerized Pulse Tools	ISO 15744		ISO 28927-2 *measured under load	
	Sound Pressure Level (L _{pk})	Sound Power Level (L _{wa})	Vibration Total Value (A _{hd})	Vibration Uncertainty (K)
	dB(A)	dB(A)	m/sec ²	m/sec ²
UXR-2400SMC	85	96	3.8	0.8

Electric Angle Nutrunners	EN62841-1		ISO 28927-2 *measured at free running	
	Sound Pressure Level (L _{pk})	Sound Power Level (L _{wa})	Vibration Total Value (A _{hd})	Vibration Uncertainty (K)
	dB(A)	dB(A)	m/sec ²	m/sec ²
UAN-F130-025	70	-	< 2.5	0.53
UAN-F130-040	70	-	< 2.5	0.54
UAN-F130-060	70	-	< 2.5	0.54
UAN-F130-080	75	-	< 2.5	0.54
UAN-F130-120	75	-	< 2.5	0.55

The noise measurement method of EN62841-1 is much aligned with ISO15744.

Pistol Grip Shut-off Pulse Tools	ISO 15744		ISO 28927-2 *measured under load	
	Sound Pressure Level (L _{pk})	Sound Power Level (L _{wa})	Vibration Total Value (A _{hd})	Vibration Uncertainty (K)
	dB(A)	dB(A)	m/sec ²	m/sec ²
UAT30D	76	-	< 2.5	0.58
UAT40	75	-	< 2.5	0.54
UAT50	78	-	< 2.5	0.55
UAT60	80	-	< 2.5	0.57
UAT70	80	-	< 2.5	0.59
UAT80	80	-	< 2.5	0.62
UAT90	82	93	< 2.5	0.63
UAT100	82	93	< 2.5	0.6
UAT130	82	93	2.6	0.7
UAT150	82	93	2.9	0.7
UAT180	84	95	3.2	0.7
UAT200	85	96	2.8	0.7
UAT200L	85	96	2.6	0.7
UAT40D	75	-	< 2.5	0.7
UAT50D	78	-	< 2.5	0.7
UAT60D	80	-	< 2.5	0.7
UAT50L	75	-	< 2.5	0.55
UAT60L	77	-	< 2.5	0.58
UAT70L	78	-	< 2.5	0.59
UAT80L	78	-	< 2.5	0.63
UAT90L	79	-	< 2.5	0.6
UAT100L	79	-	< 2.5	0.6
UAT130L	79	-	< 2.5	0.7
UAT150L	79	-	2.8	0.7
UAT180L	80	-	3.1	0.7
UAT50DL	75	-	< 2.5	0.7
UAT60DL	77	-	< 2.5	0.7

The uncertainty in the sound levels is 3dB (A).

Straight Type Shut-off Pulse Tools	ISO 15744		ISO 28927-2 *measured under load	
	Sound Pressure Level (L _{pk})	Sound Power Level (L _{wa})	Vibration Total Value (A _{hd})	Vibration Uncertainty (K)
	dB(A)	dB(A)	m/sec ²	m/sec ²
UAT40S	70	-	< 2.5	0.7
UAT50S	78	-	2.7	0.7
UAT60S	80	-	3.1	0.7
UAT70S	80	-	3.4	0.8
UAT40SD	70	-	2.7	0.7
UAT50SD	78	-	3.1	0.7
UAT60SD	80	-	3.5	0.8
UAT50SL	75	-	2.6	0.7
UAT60SL	77	-	3.0	0.7
UAT70SL	78	-	3.2	0.7
UAT50SDL	75	-	2.9	0.7
UAT60SDL	77	-	3.4	0.8
UXR-T2400S	85	96	4.0	0.8
UXR-T3000S	85	96	4.6	0.9

Angle Head Shut-off Pulse Tools	ISO 15744		ISO 28927-2 *measured under load	
	Sound Pressure Level (L _{pk})	Sound Power Level (L _{wa})	Vibration Total Value (A _{hd})	Vibration Uncertainty (K)
	dB(A)	dB(A)	m/sec ²	m/sec ²
ULT40C	70	-	10.3	1.4
ULT50C	78	-	15.4	1.8
ULT60C	80	-	16.5	1.9
ULT70C	82	93	16.7	2.0
ULT70CH	82	93	17.1	2.0
ULT50CL	75	-	13.6	1.7
ULT60CL	78	-	14.8	1.8
ULT70CL	78	-	15.2	1.8
ULT70CHL	78	-	15.6	1.9

Angle Head Non Shut-off Pulse Tools	ISO 15744		ISO 28927-2 *measured under load	
	Sound Pressure Level (L _{pk})	Sound Power Level (L _{wa})	Vibration Total Value (A _{hd})	Vibration Uncertainty (K)
	dB(A)	dB(A)	m/sec ²	m/sec ²
UX-500C	82	93	12.4	1.6
UX-612C	85	96	14.9	1.8
UX-700C	85	96	18.6	2.4
UX-800C	86	97	20.0	2.0
UX-900C	90	101	26.0	3.0
UX-1000C	90	101	18.9	2.9
UX-612A	85	96	14.1	1.7

The uncertainty in the sound levels is 3dB (A).

Pistol Grip Non Shut-off Pulse Tools	ISO 15744		ISO 28927-2 *measured under load	
	Sound Pressure Level (L _{pa})	Sound Power Level (L _{wa})	Vibration Total Value (A _{wa})	Vibration Uncertainty (K)
	dB(A)	dB(A)	m/sec ²	m/sec ²
UL30	75	-	< 2.5	0.56
UL30D	75	-	< 2.5	0.57
UL40	75	-	< 2.5	0.57
UL40D	75	-	< 2.5	0.58
UL50	78	-	< 2.5	0.59
UL50D	78	-	< 2.5	0.62
UL60	80	-	< 2.5	0.60
UL60D	80	-	< 2.5	0.7
UL70	80	-	< 2.5	0.60
UL80	80	-	< 2.5	0.60
UL90	82	93	< 2.5	0.6
UL100	80	-	< 2.5	0.6
UL130	83	94	2.7	0.7
UL150	84	95	3.0	0.7

Straight Type Non Shut-off Pulse Tools	ISO 15744		ISO 28927-2 *measured under load	
	Sound Pressure Level (L _{pa})	Sound Power Level (L _{wa})	Vibration Total Value (A _{wa})	Vibration Uncertainty (K)
	dB(A)	dB(A)	m/sec ²	m/sec ²
UL30S	72	-	< 2.5	0.7
UL30SD	75	-	2.5	0.7
UL40S	72	-	2.9	0.7
UL40SD	75	-	3.0	0.7
UL50S	78	-	3.3	0.8
UL50SD	78	-	3.2	0.7
UL60S	80	-	3.5	0.8
UL60SD	80	-	3.7	0.8
UL70S	84	95	3.7	0.8

Pistol Grip Non Shut-Off Pulse Tools	ISO 15744		ISO 28927-2 *measured under load	
	Sound Pressure Level (L _{pa})	Sound Power Level (L _{wa})	Vibration Total Value (A _{wa})	Vibration Uncertainty (K)
	dB(A)	dB(A)	m/sec ²	m/sec ²
U-350D	74	-	< 2.5	0.53
UXR-1820	84	95	2.7	0.7
UXR-2000	85	96	2.6	0.7

Straight Type Non Shut-Off Pulse Tools	ISO 15744		ISO 28927-2 *measured under load	
	Sound Pressure Level (L _{pa})	Sound Power Level (L _{wa})	Vibration Total Value (A _{wa})	Vibration Uncertainty (K)
	dB(A)	dB(A)	m/sec ²	m/sec ²
U-310SD	74	-	< 2.5	0.57
U-350SD	74	-	< 2.5	0.58
UX-900S	75	-	< 2.5	0.6
UX-1000S	75	-	2.8	0.7
UX-1300S	77	-	2.9	0.7
UXR-2000S	85	96	3.2	0.7
UXR-2400S	85	96	4.1	0.8
UXR-3000S	85	96	4.7	0.9

Stud Bolt Non Shut-off Pulse Tools	ISO 15744		ISO 28927-2 *measured under load	
	Sound Pressure Level (L _{pa})	Sound Power Level (L _{wa})	Vibration Total Value (A _{wa})	Vibration Uncertainty (K)
	dB(A)	dB(A)	m/sec ²	m/sec ²
UX-ST800	75	-	< 2.5	0.54
UX-ST1000	75	-	< 2.5	0.56

NOISE LEVELS AND VIBRATION VALUES

The uncertainty in the sound levels is 3dB (A).

Pistol Grip Impact Wrenches	ISO 15744		ISO 28927-2 *measured under load	
	Sound Pressure Level (L _{pa})	Sound Power Level (L _{wa})	Vibration Total Value (A _{hd})	Vibration Uncertainty (K)
	dB(A)	dB(A)	m/sec ²	m/sec ²
UW-6SLRK	91	102	3.8	0.8
UW-6SHBRK	92	103	4.3	0.8
UW-6SLK	92	103	3.9	0.8
UW-B6SLK	92	103	4.2	0.8
UW-6SK	93	104	3.8	0.8
UW-6SAK	93	104	4.1	0.8
UW-6SHK	92	103	4.2	0.8
UW-6SLRDK	91	102	4.1	0.8
UW-6SHBRDK	91	102	4.6	0.9
UW-6SLDK	92	103	4.3	0.8
UW-B6SLDK	92	103	4.8	0.9
UW-6SDK	93	104	4.4	0.8
UW-6SADK	93	104	4.9	0.9
UW-6SHDK	92	103	5.0	0.9

Straight Type Impact Wrenches	ISO 15744		ISO 28927-2 *measured under load	
	Sound Pressure Level (L _{pa})	Sound Power Level (L _{wa})	Vibration Total Value (A _{hd})	Vibration Uncertainty (K)
	dB(A)	dB(A)	m/sec ²	m/sec ²
UW-6SSLRK	90	101	5.3	0.9
UW-6SSRK	90	101	5.0	0.9
UW-6SSHRK	91	102	6.7	1.1
UW-6SSLK	91	102	5.3	0.9
UW-6SSK	91	102	5.0	0.9
UW-6SSHK	92	103	6.9	1.1
UW-6SSLRDK	90	101	6.0	1.0
UW-6SSRDK	90	101	6.1	1.0
UW-6SSHRDK	91	102	7.0	1.1
UW-6SSLDK	91	102	6.6	1.0
UW-6SSDK	91	102	5.5	0.9
UW-6SSHDK	92	103	7.3	1.1

Angle Head Impact Wrenches	ISO 15744		ISO 28927-2 *measured under load	
	Sound Pressure Level (L _{pa})	Sound Power Level (L _{wa})	Vibration Total Value (A _{hd})	Vibration Uncertainty (K)
	dB(A)	dB(A)	m/sec ²	m/sec ²
UW-6CSLRK	93	104	18.4	2.1
UW-6CSRK	94	105	18.0	2.1
UW-6CSHRK	94	105	27.0	3.0
UW-6ASLRK	92	103	17.8	2.0
UW-6CSLK	93	104	18.2	2.1
UW-6CSK	94	105	18.2	2.1
UW-6CSHK	94	105	27.0	3.0
UW-6ASLK	92	103	17.6	2.0

Pistol Grip Impact Wrenches	ISO 15744		ISO 28927-2 *measured under load	
	Sound Pressure Level (L _{pa})	Sound Power Level (L _{wa})	Vibration Total Value (A _{hd})	Vibration Uncertainty (K)
	dB(A)	dB(A)	m/sec ²	m/sec ²
UW-61ERK	91	102	4.0	0.8
UW-101ERK	96	107	5.8	1.0
UW-131ERK	97	108	7.6	1.1
UW-161ER	96	107	6.3	1.0
UW-8SHRK	93	104	5.6	1.0
UW-9SRK	93	104	5.1	0.9
UW-10SHRK	95	106	5.8	1.0
UW-13SRK	95	106	7.7	1.1
UW-8SHK	95	106	5.3	0.9
UW-9SK	95	106	5.0	0.9
UW-10SHK	97	108	5.8	1.0
UW-13SK	97	108	7.8	1.2

Straight Type Impact Wrenches	ISO 15744		ISO 28927-2 *measured under load	
	Sound Pressure Level (L _{pa})	Sound Power Level (L _{wa})	Vibration Total Value (A _{hd})	Vibration Uncertainty (K)
	dB(A)	dB(A)	m/sec ²	m/sec ²
UW-9SSK	95	106	10.5	1.4
UW-9SSRK	95	106	10.7	1.4
UW-13SSK	97	108	12.7	1.6

Angle Head Impact Wrenches	ISO 15744		ISO 28927-2 *measured under load	
	Sound Pressure Level (L _{pa})	Sound Power Level (L _{wa})	Vibration Total Value (A _{hd})	Vibration Uncertainty (K)
	dB(A)	dB(A)	m/sec ²	m/sec ²
UW-9CSK	95	106	31	3
UW-9CSRK	95	106	33	3
UW-13CSK	97	108	35	4

The uncertainty in the sound levels is 3dB (A).

Pistol Grip Impact Wrenches	ISO 15744		ISO 28927-2 *measured under load	
	Sound Pressure Level (L _{pa})	Sound Power Level (L _{wa})	Vibration Total Value (A _{wa})	Vibration Uncertainty (K)
	dB(A)	dB(A)	m/sec ²	m/sec ²
UW-140P	93	104	6.3	1.0
UW-140PR	93	104	6.6	1.0
UW-140PL	93	104	6.4	1.0
UW-140PRL	93	104	6.7	1.0
UW-220P	95	106	5.6	1.0
UW-220PL	95	106	5.7	1.0
UW-251P	95	106	5.7	1.0
UW-251PL	95	106	5.8	1.0
UW-022S(SHORT)	103	114	6.0	1.0
UW-022S(LONG)	103	114	5.7	1.0
UW-032S(SHORT)	109	120	6.2	1.0
UW-032S(LONG)	109	120	5.9	1.0
UW-381P	99	110	6.2	1.0
UW-381PL	99	110	6.0	1.0

Straight Type Impact Wrenches	ISO 15744		ISO 28927-2 *measured under load	
	Sound Pressure Level (L _{pa})	Sound Power Level (L _{wa})	Vibration Total Value (A _{wa})	Vibration Uncertainty (K)
	dB(A)	dB(A)	m/sec ²	m/sec ²
UW-22S(IN)	103	114	6.5	1.0
UW-22S(SHORT)	103	114	6.6	1.0
UW-22S(LONG)	103	114	6.3	1.0
UW-32SLA(SHORT)	109	120	6.2	1.0
UW-32SLA(L)	109	120	5.9	1.0
UW-381	100	111	7.6	1.1
UW-381L	100	111	7.5	1.1
UW-401(SHORT)	110	121	8.9	1.3
UW-401L	110	121	9.0	1.3

Stud Bolt Impact Wrenches	ISO 15744		ISO 28927-2 *measured under load	
	Sound Pressure Level (L _{pa})	Sound Power Level (L _{wa})	Vibration Total Value (A _{wa})	Vibration Uncertainty (K)
	dB(A)	dB(A)	m/sec ²	m/sec ²
UW-ST6SHK	92	103	4.1	0.8
UW-ST9SK	97	108	4.9	0.9
UW-ST10SHK	97	108	5.8	1.0
UW-ST6SSHK	92	103	6.6	1.0

Ratchet Wrenches	ISO 15744		ISO 28927-2 *measured under load	
	Sound Pressure Level (L _{pa})	Sound Power Level (L _{wa})	Vibration Total Value (A _{wa})	Vibration Uncertainty (K)
	dB(A)	dB(A)	m/sec ²	m/sec ²
URW-6	81	92	3.2	0.7
URW-60	85	96	3.4	0.8
URW-60R	85	96	3.4	0.8
URW-8N	90	101	3.2	0.7
URW-80	93	104	4.0	0.8
URW-80R	93	104	4.0	0.8
URW-81	93	104	4.0	0.8
URW-81R	93	104	4.0	0.8
URW-8	86	97	3.3	0.8
URW-9N	90	101	3.3	0.7
URW-10N	90	101	3.3	0.8
URW-12N	91	102	3.6	0.8
URW-12NA	91	102	3.6	0.8
URW-12NB	91	102	4.1	0.8

Open-Ended Wrenches	ISO 15744		ISO 28927-2 *measured at free running	
	Sound Pressure Level (L _{pa})	Sound Power Level (L _{wa})	Vibration Total Value (A _{wa})	Vibration Uncertainty (K)
	dB(A)	dB(A)	m/sec ²	m/sec ²
UOW-11-10	76	-	< 2.5	0.47
UOW-11-14	76	-	< 2.5	0.47
UOW-11-22	76	-	< 2.5	0.47
UOW-11-30	76	-	< 2.5	0.47
UOW-T60-10	76	-	< 2.5	0.47
UOW-T60-14	76	-	< 2.5	0.47
UOW-T60-22	76	-	< 2.5	0.47
UOW-T60-30	76	-	< 2.5	0.48

Geared Wrenches	ISO 15744		ISO 28927-2 *measured at free running	
	Sound Pressure Level (L _{pa})	Sound Power Level (L _{wa})	Vibration Total Value (A _{wa})	Vibration Uncertainty (K)
	dB(A)	dB(A)	m/sec ²	m/sec ²
UGW-6N	76	-	< 2.5	0.48
UGW-8N	76	-	< 2.5	0.48

NOISE LEVELS AND VIBRATION VALUES

The uncertainty in the sound levels is 3dB (A).

Angle Nutrunners	ISO 15744		ISO 28927-2 *measured at free running	
	Sound Pressure Level (L _{pa})	Sound Power Level (L _{wa})	Vibration Total Value (A _{hd})	Vibration Uncertainty (K)
	dB(A)	dB(A)	m/sec ²	m/sec ²
UAN-611R-60C	80	-	< 2.5	0.48
UAN-611R-50C	80	-	< 2.5	0.48
UAN-611R-40C	80	-	< 2.5	0.48
UAN-611R-30C	80	-	< 2.5	0.48
UAN-701R-60C	85	96	< 2.5	0.51
UAN-701R-40C	85	96	< 2.5	0.50
UAN-701R-30C	85	96	< 2.5	0.50
UAN-611RM-60C	80	-	< 2.5	0.49
UAN-611RM-50C	80	-	< 2.5	0.48
UAN-611RM-40C	80	-	< 2.5	0.48
UAN-611RM-30C	80	-	< 2.5	0.48
UAN-701RM-60C	85	96	< 2.5	0.51
UAN-701RM-40C	85	96	< 2.5	0.50
UAN-701RM-30C	85	96	< 2.5	0.50

Straight Screwdrivers	ISO 15744		ISO 28927-2 *measured at free running	
	Sound Pressure Level (L _{pa})	Sound Power Level (L _{wa})	Vibration Total Value (A _{hd})	Vibration Uncertainty (K)
	dB(A)	dB(A)	m/sec ²	m/sec ²
US-LT10B	75	-	< 2.5	0.48
US-LT20A(B)-26	71	-	< 2.5	0.48
US-LT20A(B)-18	70	-	< 2.5	0.48
US-LT20A(B)-10	70	-	< 2.5	0.48
US-LT30A(B)-23	71	-	< 2.5	0.48
US-LT30A(B)-17	70	-	< 2.5	0.48
US-LT30A(B)-11	70	-	< 2.5	0.48
US-LT40A(B)-21	74	-	< 2.5	0.48
US-LT40A(B)-15	70	-	< 2.5	0.48
US-LT40A(B)-08	70	-	< 2.5	0.48
US-LT50B-17	75	-	< 2.5	0.48
US-LT50B-08	75	-	< 2.5	0.48
US-LT50B-05	74	-	< 2.5	0.49
US-LT30A(B)L-23	71	-	< 2.5	0.48
US-LT30A(B)L-17	70	-	< 2.5	0.48
US-LT30A(B)L-11	70	-	< 2.5	0.48
US-LT40BL-21	74	-	< 2.5	0.48
US-LT40A(B)L-15	70	-	< 2.5	0.48
US-LT40BL-08	70	-	< 2.5	0.48

Pistol Grip Screwdrivers	ISO 15744		ISO 28927-2 *measured at free running	
	Sound Pressure Level (L _{pa})	Sound Power Level (L _{wa})	Vibration Total Value (A _{hd})	Vibration Uncertainty (K)
	dB(A)	dB(A)	m/sec ²	m/sec ²
US-LT31PB-23	70	-	< 2.5	0.48
US-LT31PB-17	70	-	< 2.5	0.48
US-LT31PB-11	70	-	< 2.5	0.48
US-LT31PB-05	70	-	< 2.5	0.48
US-LT41PB-21	74	-	< 2.5	0.48
US-LT41PB-15	70	-	< 2.5	0.48
US-LT41PB-08	70	-	< 2.5	0.48
US-LT51PB-17	75	-	< 2.5	0.48
US-LT51PB-08	75	-	< 2.5	0.48
US-LT51PB-05	74	-	< 2.5	0.49
US-LT60P-11	77	-	< 2.5	0.48
US-LT60P-07	76	-	< 2.5	0.49
US-LT60P-03	75	-	< 2.5	0.49

Angle Head Screwdrivers	ISO 15744		ISO 28927-2 *measured at free running	
	Sound Pressure Level (L _{pa})	Sound Power Level (L _{wa})	Vibration Total Value (A _{hd})	Vibration Uncertainty (K)
	dB(A)	dB(A)	m/sec ²	m/sec ²
US-LT30B-17C	73	-	< 2.5	0.48
US-LT30B-11C	73	-	< 2.5	0.48
US-LT40B-15C	75	-	< 2.5	0.48
US-LT40B-08C	75	-	< 2.5	0.48
US-LT40B-05C	75	-	< 2.5	0.48
US-LT40-08C(P)	75	-	< 2.5	0.48
US-LT40-05C(P)	75	-	< 2.5	0.48
US-LT40-03C(P)	72	-	< 2.5	0.48

Screwdrivers	ISO 15744		ISO 28927-2 *measured at free running	
	Sound Pressure Level (L _{pa})	Sound Power Level (L _{wa})	Vibration Total Value (A _{hd})	Vibration Uncertainty (K)
	dB(A)	dB(A)	m/sec ²	m/sec ²
US-3.5A	75	-	< 2.5	0.48
US-3.5B	75	-	< 2.5	0.48
US-4	75	-	< 2.5	0.48
US-5	75	-	< 2.5	0.48
US-3.5MA	75	-	< 2.5	0.48
US-40	70	-	< 2.5	0.48
US-50	76	-	< 2.5	0.48
US-3.5PB	75	-	< 2.5	0.48
US-4PB	75	-	< 2.5	0.48
US-5PB	75	-	< 2.5	0.48
US-4CA	85	96	< 2.5	0.48
US-5CA	85	96	< 2.5	0.48

The uncertainty in the sound levels is 3dB (A).

Screwdrivers	ISO 15744		ISO 28927-2 *measured at free running	
	Sound Pressure Level (L _{pa})	Sound Power Level (L _{wa})	Vibration Total Value (A _{hd})	Vibration Uncertainty (K)
	dB(A)	dB(A)	m/sec ²	m/sec ²
US-LD40P-21	74	-	< 2.5	0.48
US-LD40P-15	70	-	< 2.5	0.48
US-LD40P-08	70	-	< 2.5	0.48
US-LD50P-17	75	-	< 2.5	0.48
US-LD50P-08	75	-	< 2.5	0.48
US-LD50P-05	74	-	< 2.5	0.49

Impact Drivers	ISO 15744		ISO 28927-2 *measured under load	
	Sound Pressure Level (L _{pa})	Sound Power Level (L _{wa})	Vibration Total Value (A _{hd})	Vibration Uncertainty (K)
	dB(A)	dB(A)	m/sec ²	m/sec ²
US-350W	80	-	3.6	0.8
US-450WB	80	-	3.8	0.8
US-45W	80	-	4.0	0.8
US-3.5ACB	85	96	< 2.5	0.48
US-5W	85	96	4.7	0.9
US-6W	85	96	4.9	0.9
US-350PW	81	92	2.8	0.7
US-450PW	79	-	2.9	0.7
US-5PW	85	96	2.8	0.7
US-6PW	85	96	3.0	0.7
US-652PW	79	-	3.7	0.8

Die Grinders	ISO 15744		ISO 28927-12	
	Sound Pressure Level (L _{pa})	Sound Power Level (L _{wa})	Vibration Total Value (A _{hd})	Vibration Uncertainty (K)
	dB(A)	dB(A)	m/sec ²	m/sec ²
UG-25NA	82	93	< 2.5	0.6
G-38EB	85	96	< 2.5	0.6
UG-38N	85	96	< 2.5	0.6
UG-38NA	75	-	< 2.5	0.6
UG-38NL	85	96	4.0	0.8
UG-50S-200	73	-	2.6	0.7
UG-25NSA	82	93	< 2.5	0.59
UG-38NS	85	96	< 2.5	0.7
UG-38NSA	75	-	< 2.5	0.7
UG-38NSL	85	96	4.1	0.8
UMG-450	75	-	< 2.5	0.58
UG-45H	76	-	< 2.5	0.63
UG-20A-200	75	-	2.6	0.7
UG-20A-120	76	-	3.0	0.7
UG-50S-200A	75	-	2.8	0.7

Straight Grinders	ISO 15744		ISO 28927-4	
	Sound Pressure Level (L _{pa})	Sound Power Level (L _{wa})	Vibration Total Value (A _{hd})	Vibration Uncertainty (K)
	dB(A)	dB(A)	m/sec ²	m/sec ²
UG-65E	88	99	< 2.5	0.6
UG-65ER	85	96	< 2.5	0.6
UG-65EL	85	96	< 2.5	0.7
UG-65EB	95	106	< 2.5	0.7
UG-65EBR	95	106	< 2.5	0.7
UG-65EBL	95	106	< 2.5	0.7
UG-650E	85	96	< 2.5	0.7
UG-650ER	85	96	2.5	0.7
UG-650EL	85	96	< 2.5	0.7

Angle Grinders	ISO 15744		ISO 28927-1	
	Sound Pressure Level (L _{pa})	Sound Power Level (L _{wa})	Vibration Total Value (A _{hd})	Vibration Uncertainty (K)
	dB(A)	dB(A)	m/sec ²	m/sec ²
AG-50	80	-	< 2.5	0.7
AG-50L	80	-	< 2.5	0.7
AG-100	80	-	< 2.5	0.53
AG-100L	80	-	< 2.5	0.55
AG-100S	80	-	< 2.5	0.51
AG-100SL	80	-	< 2.5	0.52
USG-4S	80	-	3.5	1.1
USG-7S	85	96	4.7	1.4
USG-L180D	85	96	4.6	1.4

Vertical Grinders	ISO 15744		ISO 28927-1	
	Sound Pressure Level (L _{pa})	Sound Power Level (L _{wa})	Vibration Total Value (A _{hd})	Vibration Uncertainty (K)
	dB(A)	dB(A)	m/sec ²	m/sec ²
USG-4VL	88	99	< 2.5	0.6
USG-5VLA	88	99	< 2.5	0.7
UVG-1500SL-76	78	-	4.0	1.2
UVG-1500SL-84	78	-	3.9	1.2
UVG-1800SL-76	78	-	4.2	1.3
UVG-1800SL-84	78	-	4.1	1.3
UVG-2300SL-59	82	93	4.1	1.2

NOISE LEVELS AND VIBRATION VALUES

The uncertainty in the sound levels is 3dB (A).

Angle Grinders	ISO 15744		ISO 28927-1	
	Sound Pressure Level (L _{pa})	Sound Power Level (L _{wa})	Vibration Total Value (A _{hd})	Vibration Uncertainty (K)
	dB(A)	dB(A)	m/sec ²	m/sec ²
UAG-40SB-136	84	95	4.1	1.2
UAG-40SBL-136	84	95	4.1	1.3
UAG-40SC-136	84	95	4.1	1.3
UAG-40SCL-136	84	95	4.1	1.3
UAG-50SBL-120	82	93	4.1	1.2
UAG-50SCL-120	82	93	4.1	1.2
UAG-50SC-120	82	93	4.0	1.2
UAG-50SB-109	82	93	4.0	1.2
UAG-50SBL-109	82	93	4.0	1.2
UAG-70SBL-76	83	94	5.2	1.6
UAG-70SB-76	83	94	5.2	1.6
UAG-70SC-76	83	94	5.2	1.6
UAG-70SCL-76	83	94	5.2	1.6
UAG-90SBL-59	88	99	6.0	1.8

Straight Grinders	ISO 15744		ISO 28927-4	
	Sound Pressure Level (L _{pa})	Sound Power Level (L _{wa})	Vibration Total Value (A _{hd})	Vibration Uncertainty (K)
	dB(A)	dB(A)	m/sec ²	m/sec ²
UG-1250-72	88	99	< 2.5	0.7
UG-1250L-72	88	99	< 2.5	0.7
UG-1500-60	88	99	< 2.5	0.48
UG-1500-41	88	99	< 2.5	0.44
UG-1500L-60	88	99	< 2.5	0.45
UG-1500L-41	88	99	< 2.5	0.41

Sanders & Polishers	ISO 15744		ISO 28927-3	
	Sound Pressure Level (L _{pa})	Sound Power Level (L _{wa})	Vibration Total Value (A _{hd})	Vibration Uncertainty (K)
	dB(A)	dB(A)	m/sec ²	m/sec ²
USG-45P	81	92	< 2.5	0.63
UP-80-15	82	93	< 2.5	0.55
UP-80-40	84	95	< 2.5	0.56
UP-80-60	85	96	< 2.5	0.57
UP-15	87	98	6.3	1.0
UP-25DB	73	-	5.5	0.9
UP-26DB	74	-	5.8	0.9
UP-15N	94	105	6.4	1.0
UP-25NB	97	108	5.9	0.9
UP-26NB	98	109	6.0	1.0

Pistol-Grip Drills	ISO 15744		ISO 28927-5	
	Sound Pressure Level (L _{pa})	Sound Power Level (L _{wa})	Vibration Total Value (A _{hd})	Vibration Uncertainty (K)
	dB(A)	dB(A)	m/sec ²	m/sec ²
UD-50-200	73	-	< 2.5	0.61
UD-50-45	72	-	< 2.5	0.58
UD-50-22	72	-	< 2.5	0.59
UD-60-29	77	-	< 2.5	0.61
UD-60-20	77	-	< 2.5	0.60
UD-60-15	76	-	< 2.5	0.57
UD-60-07	75	-	< 2.5	0.58
UD-60-04	75	-	< 2.5	0.57
UD-80-12	79	-	< 2.5	0.60
UD-80-07	79	-	< 2.5	0.6
UD-80-04	79	-	< 2.5	0.62

Straight Drills	ISO 15744		ISO 28927-5	
	Sound Pressure Level (L _{pa})	Sound Power Level (L _{wa})	Vibration Total Value (A _{hd})	Vibration Uncertainty (K)
	dB(A)	dB(A)	m/sec ²	m/sec ²
UD-50S-200	78	-	< 2.5	0.6
UD-50S-45	77	-	< 2.5	0.61
UD-50S-22	77	-	< 2.5	0.61
UD-60S-29	77	-	< 2.5	0.6
UD-60S-20	77	-	< 2.5	0.68
UD-60S-15	77	-	< 2.5	0.67
UD-60S-07	75	-	< 2.5	0.63
UD-60S-04	75	-	< 2.5	0.63
UD-80S-12	79	-	< 2.5	0.6
UD-80S-07	79	-	< 2.5	0.6
UD-80S-04	79	-	< 2.5	0.6
UD-80-12G	79	-	< 2.5	0.65
UD-80-07G	79	-	< 2.5	0.65
UD-80-04G	79	-	< 2.5	0.63

Angle Head Drills	ISO 15744		ISO 28927-5	
	Sound Pressure Level (L _{pa})	Sound Power Level (L _{wa})	Vibration Total Value (A _{hd})	Vibration Uncertainty (K)
	dB(A)	dB(A)	m/sec ²	m/sec ²
UD-50S-45A	79	-	< 2.5	0.68
UD-50S-22A	79	-	< 2.5	0.67
UD-60S-29C	79	-	< 2.5	0.7
UD-60S-15C	79	-	< 2.5	0.69

Heavy Duty Drill	ISO 15744		ISO 28927-10	
	Sound Pressure Level (L _{pa})	Sound Power Level (L _{wa})	Vibration Total Value (A _{hd})	Vibration Uncertainty (K)
	dB(A)	dB(A)	m/sec ²	m/sec ²
URD-22RR	95	106	< 2.5	0.7

The uncertainty in the sound levels is 3dB (A).

Tappers	ISO 15744		ISO 20643	
	Sound Pressure Level (L _{pa})	Sound Power Level (L _{wa})	Vibration Total Value (A _{hd})	Vibration Uncertainty (K)
	dB(A)	dB(A)	m/sec ²	m/sec ²
UT-66B-15	85	96	< 2.5	0.61
UT-66B-07	85	96	< 2.5	0.61
UT-60-07	75	-	< 2.5	0.69
UT-60-04	75	-	< 2.5	0.59
UT-60S-07	75	-	< 2.5	0.59
UT-60S-04	75	-	< 2.5	0.56

Pistol/Straight Super Vibration-Proof Riveting Hammers	ISO 15744		ISO 28927-10	
	Sound Pressure Level (L _{pa})	Sound Power Level (L _{wa})	Vibration Total Value (A _{hd})	Vibration Uncertainty (K)
	dB(A)	dB(A)	m/sec ²	m/sec ²
BRH-1UD (R, H)	89	100	<2.5	0.9
BRH-1USD (R, H)	89	100	<2.5	0.9
BRH-5UD (R, H)	89	100	<2.5	0.9
BRH-5USD (R, H)	89	100	<2.5	0.9

Pistol/Straight Type Riveting Hammers	ISO 15744		ISO 28927-10	
	Sound Pressure Level (L _{pa})	Sound Power Level (L _{wa})	Vibration Total Value (A _{hd})	Vibration Uncertainty (K)
	dB(A)	dB(A)	m/sec ²	m/sec ²
SBH-0	90	101	< 2.5	0.6
SBH-1A (R, H)	92	103	4.5	0.9
BRH-1U (R, H)	95	106	7.8	1.1
BRH-1US (R, H)	95	106	7.5	1.1
BRH-1UG (R, H)	95	106	7.5	1.1
BRH-5U (R, H)	95	106	7.6	1.1
BRH-5US (R, H)	95	106	7.4	1.1
BRH-5UG (R, H)	95	106	7.3	1.1

Impact Cutters & Flux Chippers	ISO 15744		ISO 28927-10	
	Sound Pressure Level (L _{pa})	Sound Power Level (L _{wa})	Vibration Total Value (A _{hd})	Vibration Uncertainty (K)
	dB(A)	dB(A)	m/sec ²	m/sec ²
BRH-7 (R, H)	100	111	7.5	1.1
UFC-0N	90	101	6.0	1.0
UFC-1N	90	101	5.9	1.0

Chipping & Caulking Hammers	ISO 15744		ISO 28927-10	
	Sound Pressure Level (L _{pa})	Sound Power Level (L _{wa})	Vibration Total Value (A _{hd})	Vibration Uncertainty (K)
	dB(A)	dB(A)	m/sec ²	m/sec ²
AA-00 (R, H)	95	106	5.0	0.9
AA-20 (R, H)	100	111	5.6	1.0
AA-30 (R, H)	100	111	6.0	1.0
AA-40 (R, H)	100	111	6.3	1.0
PB-20 (R, H)	100	111	6.6	1.0
PB-30 (R, H)	100	111	7.1	1.1

(CONVERSION TABLE)

TORQUE

Unit to be converted	Nm	kgf.cm	kgf.m	in.lbs	ft.lbs
1Nm	-	10.2	0.102	8.8	0.74
1kgf.cm	0.098	-	0.01	0.868	0.072
1kgf.m	9.8	100	-	86.8	7.2
1in.lbs	0.114	1.152	1.16×10^{-2}	-	8.3×10^{-2}
1ft.lbs	1.36	13.83	0.138	12	-

PRESSURE

Unit to be converted	MPa	Bar	kgf/cm ²	psi
MPa	1	10	10.2	1.44×10^2
Bar	10	1	1.02	14.4
kgf/cm ²	9.8×10^{-2}	0.98	1	14.1
psi	6.9×10^{-2}	6.9×10^{-2}	7.1×10^{-2}	1

WEIGHT

Unit to be converted	kg	lbs
kg	1	2.2
lbs	0.45	1

HORSE POWER

Unit to be converted	kw	kgf m/s	PS	HP
kw	1	1.02×10^2	1.36	1.34
kgf m/s	9.8×10^{-5}	1	1.33×10^{-2}	1.32×10^{-2}
PS	0.74	75	1	0.99
HP	0.75	76	1.01	1

FLOW

Unit to be converted	m ³ /s	m ³ /min	l/s	ft ³ /s
m ³ /s	1	60	1.00×10^3	35
m ³ /min	1.67×10^{-2}	1	17	0.59
l/s	1.00×10^{-3}	6.0×10^{-2}	1	3.5×10^{-2}
ft ³ /s	2.8×10^{-2}	1.7	28	1

LENGTH

Unit to be converted	m	in	ft
m	1	39	3.3
in	2.54×10^{-2}	1	8.3×10^{-2}
ft	0.31	12.0	1

INDIVIDUAL CATALOG SHEETS AND PARTS LISTS ARE AVAILABLE FOR FURTHER INFORMATION.

URYU NETWORK

URYU have gained market share with the highest satisfaction of our customers not only island but also far abroad in more than 40 countries through a world-wide network of independent distributors who offer tool inspection, repair, testing, maintenance and quick delivery.

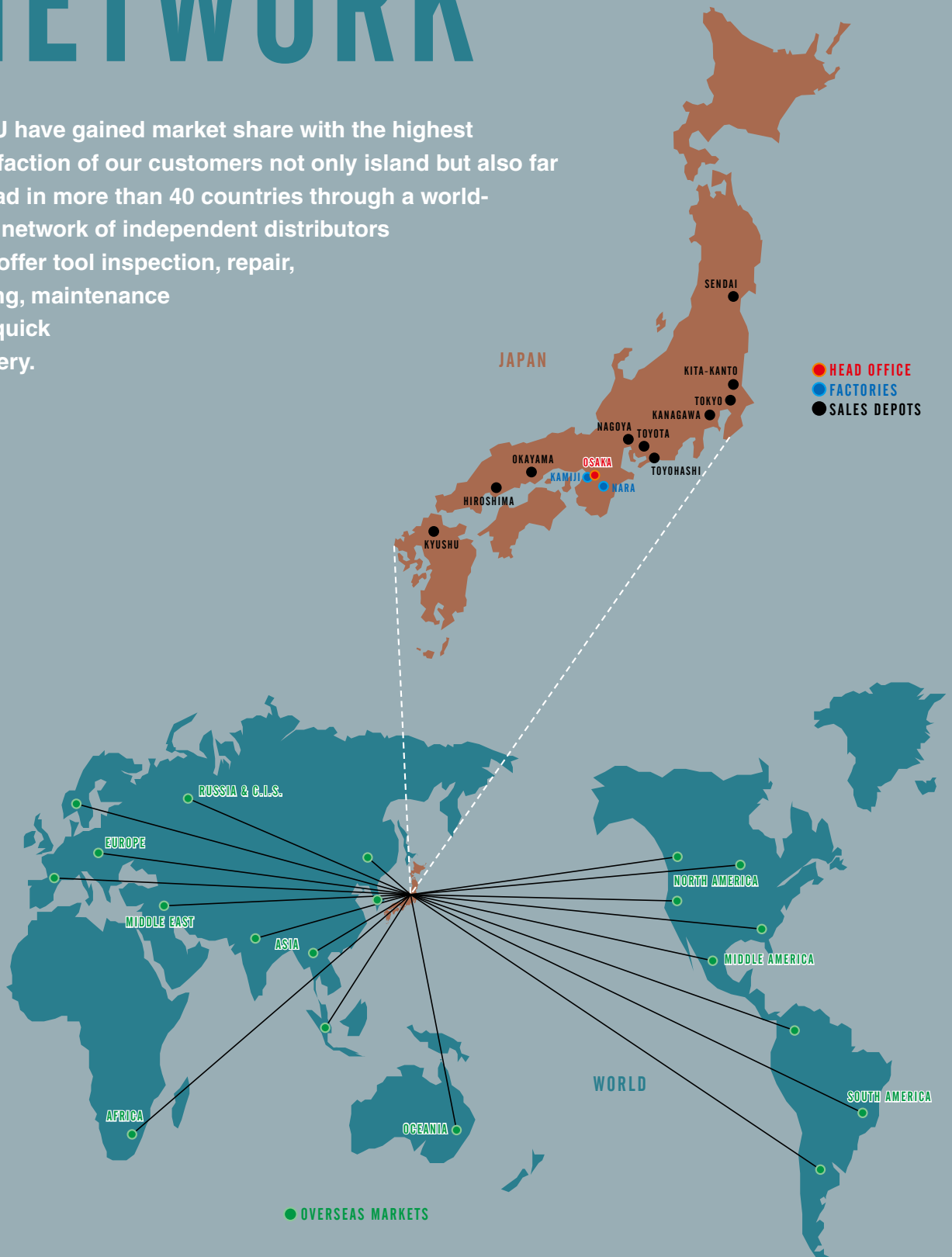

POWER TOOLS GENERAL CATALOG

BOLT & NUT SETTERS / SCREWDRIVERS / ABRASIVE TOOLS /
DRILLS & TAPPERS / PERCUSSION TOOLS / TESTERS & ACCESSORIES



www.uryu.co.jp

Specifications & contents are subject to change without notice.

 **URYU SEISAKU, LTD.**

P.O. Box 7 Higashinari, Osaka, Japan.
Telephone No : 816-6973-9414~9415
Fax : 816-6972-0346
E-Mail : uryuair@uryu.co.jp
http : //www.uryu.co.jp



17-11



DISTRIBUTED BY :

Printed in Japan
(DAI-17-11-3021)